

# Gesswein®

The Right Tools



**Precision Tools, Equipment and Supplies  
for Finishing, Polishing, Deburring, Grinding,  
Milling, Micro-Welding, Inspecting and Cleaning  
Since 1914**

# Gesswein

## The Right Tools...The Right Company

### *Gesswein Represents...*

**Quality and Value** – We offer distinguished products of the best quality as well as affordable products of great value.

**Service** – A philosophy and a way of life. It cannot be attributed to a single department, program or policy, but rather to all the things we do to ensure customers are satisfied. Service means giving customers more than they expect, immediately responding to their needs and shipping their orders the same day we take them.

**Honesty** – To our customers, ourselves and each other. We are in the business of earning and safeguarding trust, so we must always act honorably.

**Respect** – We demand respect for our customers, each other and the company. Mutual respect leads to understanding, which in turn leads to efficiency.

**Teamwork** – Our people are totally committed to working together as a team to reach our common goals.

**Investment** – We invest resources back into the company in order to keep inventory at optimal levels, to fund a technical support staff and to educate our people so they can better serve our customers.



### *Worldwide Hassle-Free Service*

Our international sales staff is waiting to serve you: they routinely schedule shipments to customers all over the world. Coordinating their efforts with expert knowledge of customs regulations, they ensure orders are expedited and delivered on time. Our service goes well beyond the point of sale. We pack shipments with care, arrange for letters of credit, prepare necessary documentation and select the most affordable shipping – all to make ordering hassle-free.

**Abrasives** .....2-79  
 Gesswein Finishing Stones • Ceramic Stones • Stone Holders • Ruby, Crystolon, India, Arkansas Stones • Mounted Stones • Dressing Stones • Cut-off Discs • Grinding Wheels • Rubberized • GMX • G-FLEX • 3M Roloc • Fiber Pads, Wheels, Discs • Coated Abrasives, PSA

**Ultrasonic Polishers** .....80-87  
 Ultramax SF/DF • Ultramax Tooling, Diamond Stones, Ruby Stones, Diamond Files, Supra Ceramic Stones, Gesswein Finishing Stones • Laps, Tool Holders and Adapters

**Power Tools** .....88-109  
 Power Hand 2X Controllers, Handpieces • Flexible Shaft Machines • Handpieces • Di-Profilers • Hangers • Mandrels • Hand Grinders

**Air Tools** .....110-115  
 Air Grinders • Filters, Regulators, Lubricators • Air Hose and Fittings

**Polishing Supplies** .....116-143  
 Brushes • Buffs • Felt Bobs and Laps • Synflex Bobs and Wheels • Selvyt • Diamond Compounds • Sticks • Buffing, Lapping and Polishing Compounds • Motors • Dust Collectors • Air Cleaning Systems • Goggles and Masks • Finger Tape, Guards, Cots

**Diamond & CBN** .....144-165  
 Files and Riffles • Grinding Wheels • Pins • Points and Wheels • Cutters • Points • Dressing Tools • Lappers • Scriber • Compound • Sheet • Cloth • Foil

**Cutting Tools** .....166-193  
 Carbide Burs • HS Burs • Busch Burs • Bur Boxes and Holders • Blanks and Cutters • Drills • Center Punch • Drill and Countersinks • Hand Reamers • End Mills • Accu-Finish Machine

**Files & Riffles** .....194-225  
 Swiss Pattern • American Pattern • Needle • Escapement • Diamond • Flexi • Poli • Handles • Riffles

**Hand Tools** .....226-255  
 Sandblasters, Blasting Media • Hammers • Mallets • Sawblades • Saw Frames • Snips • Tweezers • Pliers and Nippers • Screwdrivers • Hemostats • Pin Vises • Bench Vises • Pin Grinding Fixtures • Gravers • Scribes • Chisels • Deburring Tool • Scrapers • Knives

**Measuring, Magnifying, Lighting** .....256-271  
 Calipers • Micrometers • Dividers • Gage Sets • Telesights • Optivisor • Magni-Focusers • Loupes • Lamps

**Welding Machines** .....272-278  
 Weldmax • Weldmax Accessories • Welders

**Torches** .....279-281  
 Little Torch, The Small Torch, Regulators, Hose, Tips • Torch Lighters

**Cleaning** .....282-286  
 Ultrasonics • Ultrasonic Cleaning Solution • Cleaners/Degreasers • Steamers

**Shop & Safety Supplies** .....287-290  
 Lubricants • Cleaners • Mold Releases • Adhesives • Glasses

**Books** .....291-292

**Ordering Information, Conversion Chart** .....293-297

**Index** .....298-303

**Safety Recommendations** .....304-IBC

## Gesswein® Finishing Stones – The premier choice of professionals!

For well over 50 years, mold and die craftsmen and metalworkers the world over have looked to us for the best finishing stones. Why? Because we guarantee superior quality. To make our stones, we start with only the purest materials, then carefully grade, bond, fire and cut them to our own exacting specifications. As a result, they provide consistent finishes time and time again, without any scratching or gouging.

Available in three formulations: aluminum oxide, an extremely tough abrasive with grains that hold their sharpness very well; levigated alumina, a very fine, softer form of aluminum oxide; and silicon carbide, an extremely sharp, brittle abrasive with grains designed to shatter and expose fresh edges. Choose from 13 types for reaching any desired level of finish on hard and soft metals (listed from hardest to softest).

Type	Page(s)	Abrasive Material	Description
<b>RA</b>	4	Aluminum oxide	These aluminum oxide stones are bonded with a unique organic resin bonding agent for great resiliency, making them ideal for finishing slots, deep ribs and other hard-to-reach mold areas. Also good for removing EDM scale. Retain their shape and have flexing capability, making them resistant to breakage even during heavy use. Leave a finer finish with less stock removal than other stones of the same grit. Can be used by hand, in a profiler or in an ultrasonic polisher on all mold and die steels.
<b>EDM Blue</b>	5	Premium aluminum oxide	Harder than regular EDM Stones, EDM Blue Stones are designed specifically for use in a profiler or ultrasonic polisher to remove the tough, hard scale left by the Electrical Discharge Machining process. Make work that much faster when used in a profiler. Contain extra-sharp, premium-grade aluminum oxide for fast cutting action and a small amount of cobalt blue for added hardness. Break down slowly, cut fast and resist loading.
<b>EDM</b>	6–7	Premium aluminum oxide	Remove the tough, hard scale left by the Electrical Discharge Machining process much faster than any of our other finishing stones. Contain an extra-sharp premium-grade aluminum oxide for fast cutting action. Employ a special clay bond to hold their shape well for working small details and sharp corners. Break down slowly, cut fast and resist loading. Yield excellent results by hand but work even better in a profiler or ultrasonic polisher.
<b>GP</b>	8	White aluminum oxide	General-purpose stones made of only the very best ingredients: extra-sharp, pure white aluminum oxide grains, a specially formulated bond and a proprietary treatment. Cut well, hold their shape and resist loading. Suitable for use on both EDM and machined surfaces of all tool and hardened steels.
<b>Premium White</b>	9	Premium aluminum oxide	Premium-grade, pure white aluminum oxide stones specially formulated to resist loading. Provide excellent results on all steels, from the harder A2, D2 and M2 to the softer P20, 420SS and SAE4130. Retain their shape well, making them a good choice for finishing details. Can be used in a profiler or ultrasonic polisher.
<b>Oil-Treated</b>	9	White aluminum oxide	Hard, general-purpose aluminum oxide stones. Soaked with oil during manufacture, they can be used dry without prelubrication. Offer fine cutting ability. Hold shape for finishing mold details. Excellent for machined surfaces. Can be used in a profiler or ultrasonic polisher.
<b>Diemaker</b>	10–11	Aluminum oxide	By far our most popular finishing stones, these medium-hard aluminum oxide stones combine the characteristics of fast cutting and moderate breakdown. Ideal for general-purpose stoning on hard and soft grades of mold steel and for prefinishing aluminum, beryllium copper and kirksite. Can be used in a profiler or ultrasonic polisher.



Type	Page	Abrasive Material	Description
<b>Moldmaker Plus</b>	12	Premium silicon carbide	Premium complements to Moldmaker Stones, these medium-hard, green silicon carbide stones feature slower breakdown characteristics. A good choice for stoning contours and radii. Produce a silky matte finish on all prehardened tool steels, from 28HRC SAE 4130 through 60HRC A2 and M2. Can also be used to rough out aluminum, beryllium copper and kirksite.
<b>Moldmaker</b>	13	Silicon carbide	Made of silicon carbide abrasive with a specially formulated bonding agent that permits rapid breakdown to inhibit loading. Ideal for blending, detailing radii or following contours. Suitable for working on all types of steels and roughing out nonferrous metals. Can be used by hand or in a profiler.
<b>Rough Out</b>	14	Aluminum oxide	Large, coarse, relatively soft aluminum oxide stones. Cut fast with rapid breakdown. Designed for quickly removing rough machining marks and hogging out large amounts of metal prior to the finishing process.
<b>White Polishing</b>	14	Aluminum oxide	Soft and chalk-like aluminum oxide finishing stones made to break down rapidly. Remove light scratches from metal surfaces. Excellent for final finishing prior to using diamond compound. Best used by hand.
<b>Super Fine</b>	15	Levigated alumina	Some of the softest stones available for finishing steel surfaces. Contain levigated (finely powdered) alumina. Break down very rapidly and will not scratch. Can be used to produce a final finish or to prepare surfaces for polishing with diamond compound. An excellent choice for P20 and 420SS steels. Not quite as soft as Ultra-Soft Stones.
<b>Ultra-Soft</b>	15	White aluminum oxide	These aluminum oxide stones are bonded with an extra-soft bonding agent for very rapid breakdown (more rapid than Moldmaker Stones). Formulated for use on soft metals, including aluminum, stainless steel, brass, beryllium and kirksite. Cut fast and absolutely will not load. Can be easily shaped for finishing all types of contours.

Stone Type	Surface					Method			Use		Breakdown 0 = Slow; 5 = Fast	Hardness 0 = Soft; 5 = Hard
	EDM	Tool Steel	Stainless Steel	Non-ferrous	Aluminum	Hand	Profiler	Ultrasonic Polisher	Wet	Dry		
RA	X	X				X	X	X	X		2	4
EDM Blue	X	X				X	X	X	X		2	4
EDM	X	X				X	X	X	X		3	3
GP	X	X				X	X		X	X	3	3
Premium White		X				X	X		X	X	3	3
Oil-Treated		X				X	X	X	X	X	3	3
Diemaker		X	X	X		X	X	X	X		4	2
Moldmaker Plus		X	X		X	X			X		4	2
Moldmaker		X	X	X		X		X	X		4	2
Rough Out		X	X	X		X			X		4	2
White Polishing		X	X	X		X			X		4	2
Super Fine		X	X	X		X			X		4	2
Ultra-Soft		X	X	X	X	X			X		5	1



## Gesswein® RA Stones

Aluminum oxide abrasive bonded together with a unique organic resin bond gives these stones great resiliency, making them ideal for finishing slots, deep ribs and other hard-to-reach mold areas. They can also be used to remove EDM scale. RA stones retain their shape and have a flexing capability, making them resistant to breakage even during heavy use. They leave a finer finish with less stock removal than other stones of the same grit size. RA stones can be used by hand, in a profiler or in an ultrasonic polisher on all mold and die steels.

$\frac{5}{32}$ " x  $\frac{5}{32}$ " x 4"



Style	Grit	Item#	EACH Prices	
			1-11	12-71
RA41	180	<b>415-0410</b>	<b>\$2.44</b>	<b>\$2.03</b>
RA42	220	<b>415-0420</b>	<b>2.44</b>	<b>2.03</b>
RA43	320	<b>415-0430</b>	<b>2.57</b>	<b>2.14</b>
RA44	400	<b>415-0440</b>	<b>2.57</b>	<b>2.14</b>
RA46	600	<b>415-0460</b>	<b>2.92</b>	<b>2.43</b>

$\frac{1}{4}$ " x  $\frac{1}{8}$ " x 6"



Style	Grit	Item#	EACH Prices	
			1-11	12-71
RA4091	90	<b>420-4091</b>	<b>\$3.15</b>	<b>\$2.62</b>
RA4121	120	<b>420-4121</b>	<b>3.15</b>	<b>2.62</b>
RA4181	180	<b>420-4181</b>	<b>3.15</b>	<b>2.62</b>
RA4201	220	<b>420-4201</b>	<b>3.15</b>	<b>2.62</b>
RA4301	320	<b>420-4301</b>	<b>4.14</b>	<b>3.45</b>
RA4401	400	<b>420-4401</b>	<b>4.14</b>	<b>3.45</b>
RA4601	600	<b>420-4601</b>	<b>5.01</b>	<b>4.17</b>

$\frac{1}{4}$ " x  $\frac{1}{4}$ " x 6"



Style	Grit	Item#	EACH Prices	
			1-11	12-71
RA4092	90	<b>420-4092</b>	<b>\$3.27</b>	<b>\$2.72</b>
RA4122	120	<b>420-4122</b>	<b>3.27</b>	<b>2.72</b>
RA4182	180	<b>420-4182</b>	<b>3.27</b>	<b>2.72</b>
RA4202	220	<b>420-4202</b>	<b>3.27</b>	<b>2.72</b>
RA4302	320	<b>420-4302</b>	<b>4.69</b>	<b>3.91</b>
RA4402	400	<b>420-4402</b>	<b>4.69</b>	<b>3.91</b>
RA4602	600	<b>420-4602</b>	<b>5.34</b>	<b>4.45</b>

$\frac{1}{2}$ " x  $\frac{1}{16}$ " x 6"



Style	Grit	Item#	EACH Prices	
			1-11	12-71
RA4120	120	<b>420-4120</b>	<b>\$3.65</b>	<b>\$3.04</b>
RA4180	180	<b>420-4180</b>	<b>3.65</b>	<b>3.04</b>
RA4200	220	<b>420-4200</b>	<b>3.65</b>	<b>3.04</b>
RA4300	320	<b>420-4300</b>	<b>5.32</b>	<b>4.43</b>
RA4400	400	<b>420-4400</b>	<b>5.32</b>	<b>4.43</b>
RA4600	600	<b>420-4600</b>	<b>6.15</b>	<b>5.12</b>

$\frac{1}{2}$ " x  $\frac{1}{8}$ " x 6"



Style	Grit	Item#	EACH Prices	
			1-11	12-71
RA4093	90	<b>420-4093</b>	<b>\$3.65</b>	<b>\$3.04</b>
RA4123	120	<b>420-4123</b>	<b>3.65</b>	<b>3.04</b>
RA4183	180	<b>420-4183</b>	<b>3.65</b>	<b>3.04</b>
RA4203	220	<b>420-4203</b>	<b>3.65</b>	<b>3.04</b>
RA4303	320	<b>420-4303</b>	<b>5.32</b>	<b>4.43</b>
RA4403	400	<b>420-4403</b>	<b>5.32</b>	<b>4.43</b>
RA4603	600	<b>420-4603</b>	<b>6.15</b>	<b>5.12</b>

$\frac{1}{2}$ " x  $\frac{1}{4}$ " x 6"



Style	Grit	Item#	EACH Prices	
			1-11	12-71
RA4094	90	<b>420-4094</b>	<b>\$4.21</b>	<b>\$3.51</b>
RA4124	120	<b>420-4124</b>	<b>4.21</b>	<b>3.51</b>
RA4184	180	<b>420-4184</b>	<b>4.21</b>	<b>3.51</b>
RA4204	220	<b>420-4204</b>	<b>4.21</b>	<b>3.51</b>
RA4304	320	<b>420-4304</b>	<b>6.08</b>	<b>5.07</b>
RA4404	400	<b>420-4404</b>	<b>6.08</b>	<b>5.07</b>
RA4604	600	<b>420-4604</b>	<b>7.02</b>	<b>5.85</b>

Round,  $\frac{5}{32}$ " x 4"



Style	Grit	Item#	EACH Prices	
			1-11	12-71
RA33	320	<b>420-0033</b>	<b>\$5.72</b>	<b>\$4.77</b>

### Additional Quantity Discounts On All Finishing Stones!

Discounts off one-piece prices;  
mixed orders do not qualify.

72-143	<b>25% off</b>
144+	<b>33% off</b>



$\frac{5}{32}$ " x  $\frac{5}{32}$ " x 4"



Style	Grit	Item#	EACH Prices	
			1-11	12-71
61B	120	<b>415-6010</b>	<b>\$2.03</b>	<b>\$1.69</b>
62B	180	<b>415-6020</b>	<b>2.03</b>	<b>1.69</b>
622B	220	<b>415-6022</b>	<b>2.03</b>	<b>1.69</b>
63B	320	<b>415-6030</b>	<b>2.03</b>	<b>1.69</b>
64B	400	<b>415-6040</b>	<b>2.03</b>	<b>1.69</b>
66B	600	<b>415-6060</b>	<b>2.29</b>	<b>1.91</b>

**Gesswein® EDM Blue Stones**

Harder than our regular EDM Stones, our new EDM Blue Stones were designed specifically for use in a profiler or ultrasonic polisher to remove the tough, hard scale left by the Electrical Discharge Machining process. Using these stones with a profiler makes work that much faster. They contain an extra-sharp premium-grade aluminum oxide for fast cutting action and a small amount of cobalt blue for added hardness. EDM Blue Stones break down slowly, cut fast and resist loading.

$\frac{1}{4}$ " x  $\frac{1}{8}$ " x 6"



Style	Grit	Item#	EACH Prices	
			1-11	12-71
6121B	120	<b>424-6121</b>	<b>\$2.90</b>	<b>\$2.42</b>
6181B	180	<b>424-6181</b>	<b>2.90</b>	<b>2.42</b>
6201B	220	<b>424-6201</b>	<b>2.90</b>	<b>2.42</b>
6301B	320	<b>424-6301</b>	<b>3.10</b>	<b>2.58</b>
6401B	400	<b>424-6401</b>	<b>3.10</b>	<b>2.58</b>
6601B	600	<b>424-6601</b>	<b>3.59</b>	<b>2.99</b>

$\frac{1}{2}$ " x  $\frac{1}{16}$ " x 6"



Style	Grit	Item#	EACH Prices	
			1-11	12-71
6120B	120	<b>424-6120</b>	<b>\$3.15</b>	<b>\$2.62</b>
6180B	180	<b>424-6180</b>	<b>3.15</b>	<b>2.62</b>
6200B	220	<b>424-6200</b>	<b>3.15</b>	<b>2.62</b>
6300B	320	<b>424-6300</b>	<b>3.50</b>	<b>2.92</b>
6400B	400	<b>424-6400</b>	<b>3.50</b>	<b>2.92</b>
6600B	600	<b>424-6600</b>	<b>4.00</b>	<b>3.33</b>

$\frac{1}{4}$ " x  $\frac{1}{4}$ " x 6"



Style	Grit	Item#	EACH Prices	
			1-11	12-71
6122B	120	<b>424-6122</b>	<b>\$3.06</b>	<b>\$2.55</b>
6182B	180	<b>424-6182</b>	<b>3.06</b>	<b>2.55</b>
6202B	220	<b>424-6202</b>	<b>3.06</b>	<b>2.55</b>
6302B	320	<b>424-6302</b>	<b>3.27</b>	<b>2.72</b>
6402B	400	<b>424-6402</b>	<b>3.27</b>	<b>2.72</b>
6602B	600	<b>424-6602</b>	<b>3.94</b>	<b>3.28</b>

$\frac{1}{2}$ " x  $\frac{1}{8}$ " x 6"



Style	Grit	Item#	EACH Prices	
			1-11	12-71
6123B	120	<b>424-6123</b>	<b>\$3.29</b>	<b>\$2.74</b>
6183B	180	<b>424-6183</b>	<b>3.29</b>	<b>2.74</b>
6203B	220	<b>424-6203</b>	<b>3.29</b>	<b>2.74</b>
6303B	320	<b>424-6303</b>	<b>3.50</b>	<b>2.92</b>
6403B	400	<b>424-6403</b>	<b>3.50</b>	<b>2.92</b>
6603B	600	<b>424-6603</b>	<b>4.84</b>	<b>4.03</b>

$\frac{1}{2}$ " x  $\frac{1}{4}$ " x 6"



Style	Grit	Item#	EACH Prices	
			1-11	12-71
6124B	120	<b>424-6124</b>	<b>\$3.98</b>	<b>\$3.32</b>
6184B	180	<b>424-6184</b>	<b>3.98</b>	<b>3.32</b>
6204B	220	<b>424-6204</b>	<b>3.98</b>	<b>3.32</b>
6304B	320	<b>424-6304</b>	<b>4.42</b>	<b>3.68</b>
6404B	400	<b>424-6404</b>	<b>4.42</b>	<b>3.68</b>
6604B	600	<b>424-6604</b>	<b>6.39</b>	<b>5.32</b>

Round,  $\frac{1}{4}$ " x 6"



Style	Grit	Item#	EACH Prices	
			1-11	12-71
E122B	120	<b>424-0122</b>	<b>\$5.68</b>	<b>\$4.73</b>
E182B	180	<b>424-0182</b>	<b>5.68</b>	<b>4.73</b>
E302B	320	<b>424-0302</b>	<b>8.11</b>	<b>6.76</b>

**Additional  
Quantity Discounts  
On All Finishing Stones!**

Discounts off one-piece prices;  
mixed orders do not qualify.

72-143	<b>25% off</b>
144+	<b>33% off</b>

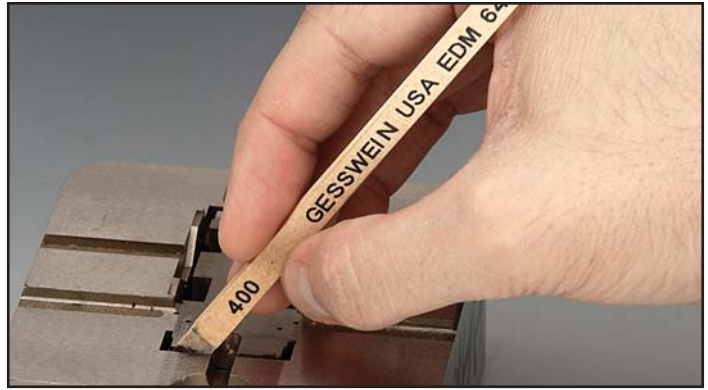

## Gesswein® EDM Stones

Our EDM stones remove the tough, hard scale left by the Electrical Discharge Machining process much faster than any of our other finishing stones. They contain an extra-sharp premium-grade aluminum oxide for fast cutting action. A special clay bond enables the EDM stones to hold their shape well for working small details and sharp corners. EDM stones break down slowly, cut fast and resist loading. They yield excellent results by hand but work even better in a profiler or ultrasonic polisher.

$\frac{5}{32}$ " x  $\frac{5}{32}$ " x 4"



Style	Grit	Item#	EACH Prices	
			1-11	12-71
61	120	<b>415-0610</b>	<b>\$2.03</b>	<b>\$1.69</b>
62	180	<b>415-0620</b>	<b>2.03</b>	<b>1.69</b>
622	220	<b>415-0622</b>	<b>2.03</b>	<b>1.69</b>
63	320	<b>415-0630</b>	<b>2.03</b>	<b>1.69</b>
64	400	<b>415-0640</b>	<b>2.03</b>	<b>1.69</b>
66	600	<b>415-0660</b>	<b>2.29</b>	<b>1.91</b>

$\frac{1}{4}$ " x  $\frac{1}{16}$ " x 4"



Style	Grit	Item#	EACH Prices	
			1-11	12-71
6110	180	<b>425-6110</b>	<b>\$1.50</b>	<b>\$1.25</b>
6210	220	<b>425-6210</b>	<b>1.58</b>	<b>1.32</b>
6310	320	<b>425-6310</b>	<b>1.76</b>	<b>1.47</b>
6410	400	<b>425-6410</b>	<b>1.76</b>	<b>1.47</b>
6610	600	<b>425-6610</b>	<b>2.02</b>	<b>1.68</b>

$\frac{1}{4}$ " x  $\frac{1}{8}$ " x 6"



Style	Grit	Item#	EACH Prices	
			1-11	12-71
6121	120	<b>425-6121</b>	<b>\$2.90</b>	<b>\$2.42</b>
6181	180	<b>425-6181</b>	<b>2.90</b>	<b>2.42</b>
6201	220	<b>425-6201</b>	<b>2.90</b>	<b>2.42</b>
6301	320	<b>425-6301</b>	<b>3.10</b>	<b>2.58</b>
6401	400	<b>425-6401</b>	<b>3.10</b>	<b>2.58</b>
6601	600	<b>425-6601</b>	<b>3.59</b>	<b>2.99</b>

$\frac{1}{4}$ " x  $\frac{1}{4}$ " x 6"



Style	Grit	Item#	EACH Prices	
			1-11	12-71
6122	120	<b>425-6122</b>	<b>\$3.06</b>	<b>\$2.55</b>
6182	180	<b>425-6182</b>	<b>3.06</b>	<b>2.55</b>
6202	220	<b>425-6202</b>	<b>3.06</b>	<b>2.55</b>
6302	320	<b>425-6302</b>	<b>3.27</b>	<b>2.72</b>
6402	400	<b>425-6402</b>	<b>3.27</b>	<b>2.72</b>
6602	600	<b>425-6602</b>	<b>3.94</b>	<b>3.28</b>

$\frac{3}{8}$ " x  $\frac{3}{8}$ " x 6"



Style	Grit	Item#	EACH Prices	
			1-11	12-71
6128	120	<b>425-6128</b>	<b>\$4.17</b>	<b>\$3.47</b>
6188	180	<b>425-6188</b>	<b>4.17</b>	<b>3.47</b>
6208	220	<b>425-6208</b>	<b>4.17</b>	<b>3.47</b>
6308	320	<b>425-6308</b>	<b>4.59</b>	<b>3.82</b>

$\frac{1}{2}$ " x  $\frac{1}{16}$ " x 6"



Style	Grit	Item#	EACH Prices	
			1-11	12-71
6120	120	<b>425-6120</b>	<b>\$3.15</b>	<b>\$2.62</b>
6180	180	<b>425-6180</b>	<b>3.15</b>	<b>2.62</b>
6200	220	<b>425-6200</b>	<b>3.15</b>	<b>2.62</b>
6300	320	<b>425-6300</b>	<b>3.50</b>	<b>2.92</b>
6400	400	<b>425-6400</b>	<b>3.50</b>	<b>2.92</b>
6600	600	<b>425-6600</b>	<b>4.00</b>	<b>3.33</b>

$\frac{1}{2}$ " x  $\frac{1}{8}$ " x 6"



Style	Grit	Item#	EACH Prices	
			1-11	12-71
6123	120	<b>425-6123</b>	<b>\$3.29</b>	<b>\$2.74</b>
6183	180	<b>425-6183</b>	<b>3.29</b>	<b>2.74</b>
6203	220	<b>425-6203</b>	<b>3.29</b>	<b>2.74</b>
6303	320	<b>425-6303</b>	<b>3.50</b>	<b>2.92</b>
6403	400	<b>425-6403</b>	<b>3.50</b>	<b>2.92</b>
6603	600	<b>425-6603</b>	<b>4.84</b>	<b>4.03</b>



**Additional  
Quantity Discounts  
On All Finishing Stones!**

Discounts off one-piece prices;  
mixed orders do not qualify.

72-143	<b>25% off</b>
144+	<b>33% off</b>



1/2" x 1/4" x 6"



Style	Grit	Item#	EACH Prices	
			1-11	12-71
6124	120	<b>425-6124</b>	<b>\$3.98</b>	<b>\$3.32</b>
6184	180	<b>425-6184</b>	<b>3.98</b>	<b>3.32</b>
6204	220	<b>425-6204</b>	<b>3.98</b>	<b>3.32</b>
6304	320	<b>425-6304</b>	<b>4.42</b>	<b>3.68</b>
6404	400	<b>425-6404</b>	<b>4.42</b>	<b>3.68</b>
6604	600	<b>425-6604</b>	<b>6.39</b>	<b>5.32</b>

1" x 1" x 6"



Style	Grit	Item#	EACH Prices	
			1-5	6-71
6126	120	<b>425-6126</b>	<b>\$12.06</b>	<b>\$10.05</b>
6186	180	<b>425-6186</b>	<b>12.06</b>	<b>10.05</b>
6206	220	<b>425-6206</b>	<b>12.06</b>	<b>10.05</b>
6306	320	<b>425-6306</b>	<b>16.56</b>	<b>13.80</b>

1/2" x 1/2" x 6"



Style	Grit	Item#	EACH Prices	
			1-5	6-71
6125	120	<b>425-6125</b>	<b>\$5.04</b>	<b>\$4.20</b>
6185	180	<b>425-6185</b>	<b>5.04</b>	<b>4.20</b>
6205	220	<b>425-6205</b>	<b>5.04</b>	<b>4.20</b>
6305	320	<b>425-6305</b>	<b>7.30</b>	<b>6.08</b>
6405	400	<b>425-6405</b>	<b>7.30</b>	<b>6.08</b>
6605	600	<b>425-6605</b>	<b>9.47</b>	<b>7.89</b>

Round, 1/4" x 6"



Style	Grit	Item#	EACH Prices	
			1-11	12-71
E122	120	<b>425-0122</b>	<b>\$5.68</b>	<b>\$4.73</b>
E182	180	<b>425-0182</b>	<b>5.68</b>	<b>4.73</b>
E222	220	<b>425-0222</b>	<b>5.68</b>	<b>4.73</b>
E302	320	<b>425-0302</b>	<b>8.11</b>	<b>6.76</b>
E402	400	<b>425-0402</b>	<b>8.11</b>	<b>6.76</b>
E602	600	<b>425-0602</b>	<b>10.49</b>	<b>8.74</b>

3/4" x 1/4" x 6"



Style	Grit	Item#	EACH Prices	
			1-5	6-71
6129	120	<b>425-6129</b>	<b>\$4.63</b>	<b>\$3.86</b>
6189	180	<b>425-6189</b>	<b>4.63</b>	<b>3.86</b>
6209	220	<b>425-6209</b>	<b>4.63</b>	<b>3.86</b>
6309	320	<b>425-6309</b>	<b>6.16</b>	<b>5.13</b>

Triangular, 1/4" x 6"



Style	Grit	Item#	EACH Prices	
			1-11	12-71
61T2	120	<b>425-6192</b>	<b>\$3.68</b>	<b>\$3.07</b>
62T2	180	<b>425-6292</b>	<b>3.68</b>	<b>3.07</b>
63T2	320	<b>425-6392</b>	<b>3.92</b>	<b>3.27</b>

1" x 1/4" x 6"



Style	Grit	Item#	EACH Prices	
			1-5	6-71
6012	120	<b>425-6012</b>	<b>\$4.67</b>	<b>\$3.89</b>
6112	180	<b>425-6112</b>	<b>4.67</b>	<b>3.89</b>
6212	220	<b>425-6212</b>	<b>4.67</b>	<b>3.89</b>
6312	320	<b>425-6312</b>	<b>7.36</b>	<b>6.13</b>

Triangular, 3/8" x 6"



Style	Grit	Item#	EACH Prices	
			1-11	12-71
61T8	120	<b>425-6198</b>	<b>\$4.92</b>	<b>\$4.10</b>
62T8	180	<b>425-6298</b>	<b>4.92</b>	<b>4.10</b>
63T8	320	<b>425-6398</b>	<b>5.51</b>	<b>4.59</b>

1" x 1/2" x 6"



Style	Grit	Item#	EACH Prices	
			1-5	6-71
6127	120	<b>425-6127</b>	<b>\$6.99</b>	<b>\$5.82</b>
6187	180	<b>425-6187</b>	<b>6.99</b>	<b>5.82</b>
6207	220	<b>425-6207</b>	<b>6.99</b>	<b>5.82</b>
6307	320	<b>425-6307</b>	<b>11.00</b>	<b>9.17</b>



## Gesswein® GP Stones

Made of only the very best ingredients: extra-sharp pure white aluminum oxide grains, a specially formulated bond and a proprietary treatment. Cut well, hold their shape and resist loading. Suitable for use on both EDM and machined surfaces of all tool and hardened steels.

5/32" x 5/32" x 4"



Style	Grit	Item#	EACH Prices	
			1-11	12-71
15G	150	<b>415-0315</b>	<b>\$2.03</b>	<b>\$1.69</b>
18G	180	<b>415-0318</b>	<b>2.03</b>	<b>1.69</b>
22G	220	<b>415-0320</b>	<b>2.03</b>	<b>1.69</b>
32G	320	<b>415-0330</b>	<b>2.03</b>	<b>1.69</b>
42G	400	<b>415-0340</b>	<b>2.03</b>	<b>1.69</b>
60G	600	<b>415-0360</b>	<b>2.29</b>	<b>1.91</b>

1/4" x 1/8" x 6"



Style	Grit	Item#	EACH Prices	
			1-11	12-71
6121G	150	<b>406-6151</b>	<b>\$3.15</b>	<b>\$2.62</b>
6181G	180	<b>406-6181</b>	<b>3.15</b>	<b>2.62</b>
6201G	220	<b>406-6201</b>	<b>3.15</b>	<b>2.62</b>
6301G	320	<b>406-6301</b>	<b>3.27</b>	<b>2.72</b>
6401G	400	<b>406-6401</b>	<b>3.27</b>	<b>2.72</b>
6601G	600	<b>406-6601</b>	<b>3.77</b>	<b>3.14</b>

1/4" x 1/4" x 6"



Style	Grit	Item#	EACH Prices	
			1-11	12-71
6152G	150	<b>406-6152</b>	<b>\$3.29</b>	<b>\$2.74</b>
6182G	180	<b>406-6182</b>	<b>3.29</b>	<b>2.74</b>
6202G	220	<b>406-6202</b>	<b>3.29</b>	<b>2.74</b>
6302G	320	<b>406-6302</b>	<b>3.43</b>	<b>2.86</b>
6402G	400	<b>406-6402</b>	<b>3.43</b>	<b>2.86</b>
6602G	600	<b>406-6602</b>	<b>4.28</b>	<b>3.57</b>

1/2" x 1/8" x 6"



Style	Grit	Item#	EACH Prices	
			1-11	12-71
6153G	150	<b>406-6153</b>	<b>\$3.43</b>	<b>\$2.86</b>
6183G	180	<b>406-6183</b>	<b>3.43</b>	<b>2.86</b>
6203G	220	<b>406-6203</b>	<b>3.43</b>	<b>2.86</b>
6303G	320	<b>406-6303</b>	<b>3.65</b>	<b>3.04</b>
6403G	400	<b>406-6403</b>	<b>3.65</b>	<b>3.04</b>
6603G	600	<b>406-6603</b>	<b>4.53</b>	<b>3.77</b>

1/2" x 1/4" x 6"



Style	Grit	Item#	EACH Prices	
			1-11	12-71
6154G	150	<b>406-6154</b>	<b>\$4.32</b>	<b>\$3.60</b>
6184G	180	<b>406-6184</b>	<b>4.32</b>	<b>3.60</b>
6204G	220	<b>406-6204</b>	<b>4.32</b>	<b>3.60</b>
6304G	320	<b>406-6304</b>	<b>5.03</b>	<b>4.19</b>
6404G	400	<b>406-6404</b>	<b>5.03</b>	<b>4.19</b>
6604G	600	<b>406-6604</b>	<b>6.30</b>	<b>5.25</b>

Round, 1/4" x 6"



Style	Grit	Item#	EACH Prices	
			1-11	12-71
GP152	150	<b>406-0152</b>	<b>\$5.96</b>	<b>\$4.97</b>
GP182	180	<b>406-0182</b>	<b>5.96</b>	<b>4.97</b>
GP222	220	<b>406-0222</b>	<b>5.96</b>	<b>4.97</b>
GP322	320	<b>406-0322</b>	<b>8.52</b>	<b>7.10</b>
GP402	400	<b>406-0402</b>	<b>8.52</b>	<b>7.10</b>
GP602	600	<b>406-0602</b>	<b>11.02</b>	<b>9.18</b>

## Additional Quantity Discounts On All Finishing Stones!

Discounts off one-piece prices; mixed orders do not qualify.

72-143	<b>25% off</b>
144+	<b>33% off</b>



**Gesswein® Premium White Stones**

Pure white premium-grade aluminum oxide stones specially formulated to be load-resistant. These semihard stones can be used on all steels, from the hard A2, D2 and M2 to the softer P20, 420SS and SAE4130. Retain their shape well, making them a good choice for finishing details. Can be used in a profiler or ultrasonic polisher.

5/32" x 5/32" x 4"

Style	Grit	Item#	EACH Prices	
			1-11	12-71
2W	220	<b>415-5002</b>	<b>\$2.24</b>	<b>\$1.87</b>
3W	320	<b>415-5003</b>	<b>2.24</b>	<b>1.87</b>
4W	400	<b>415-5004</b>	<b>2.24</b>	<b>1.87</b>
6W	600	<b>415-5006</b>	<b>2.52</b>	<b>2.10</b>

1/4" x 1/16" x 4"

Style	Grit	Item#	EACH Prices	
			1-11	12-71
5210W	220	<b>407-5210</b>	<b>\$2.21</b>	<b>\$1.84</b>
5310W	320	<b>407-5310</b>	<b>2.46</b>	<b>2.05</b>
5410W	400	<b>407-5410</b>	<b>2.46</b>	<b>2.05</b>

1/4" x 1/8" x 6"

Style	Grit	Item#	EACH Prices	
			1-11	12-71
5101W	100	<b>407-5101</b>	<b>\$3.05</b>	<b>\$2.54</b>
5151W	150	<b>407-5151</b>	<b>3.05</b>	<b>2.54</b>
5201W	220	<b>407-5201</b>	<b>3.05</b>	<b>2.54</b>
5301W	320	<b>407-5301</b>	<b>3.27</b>	<b>2.72</b>
5401W	400	<b>407-5401</b>	<b>3.27</b>	<b>2.72</b>
5601W	600	<b>407-5601</b>	<b>3.76</b>	<b>3.13</b>

1/4" x 1/4" x 6"

Style	Grit	Item#	EACH Prices	
			1-11	12-71
5102W	100	<b>407-5102</b>	<b>\$3.36</b>	<b>\$2.80</b>
5152W	150	<b>407-5152</b>	<b>3.36</b>	<b>2.80</b>
5202W	220	<b>407-5202</b>	<b>3.36</b>	<b>2.80</b>
5302W	320	<b>407-5302</b>	<b>3.59</b>	<b>2.99</b>
5402W	400	<b>407-5402</b>	<b>3.59</b>	<b>2.99</b>
5602W	600	<b>407-5602</b>	<b>4.32</b>	<b>3.60</b>

1/2" x 1/8" x 6"

Style	Grit	Item#	EACH Prices	
			1-11	12-71
5103W	100	<b>407-5103</b>	<b>\$3.45</b>	<b>\$2.87</b>
5153W	150	<b>407-5153</b>	<b>3.45</b>	<b>2.87</b>
5203W	220	<b>407-5203</b>	<b>3.45</b>	<b>2.87</b>
5303W	320	<b>407-5303</b>	<b>3.66</b>	<b>3.05</b>
5403W	400	<b>407-5403</b>	<b>3.66</b>	<b>3.05</b>
5603W	600	<b>407-5603</b>	<b>5.08</b>	<b>4.23</b>

1/2" x 1/4" x 6"

Style	Grit	Item#	EACH Prices	
			1-11	12-71
5104W	100	<b>407-5104</b>	<b>\$4.17</b>	<b>\$3.47</b>
5154W	150	<b>407-5154</b>	<b>4.17</b>	<b>3.47</b>
5204W	220	<b>407-5204</b>	<b>4.17</b>	<b>3.47</b>
5304W	320	<b>407-5304</b>	<b>4.62</b>	<b>3.85</b>
5404W	400	<b>407-5404</b>	<b>4.62</b>	<b>3.85</b>
5604W	600	<b>407-5604</b>	<b>6.69</b>	<b>5.57</b>



**Gesswein® Oil-Treated Stones**

Oil-Treated Stones are hard, general purpose stones made of aluminum oxide abrasive. Soaked with oil during manufacture, they can be used dry without prelubrication. Fine cutting ability. Hold shape for finishing mold details. Excellent for machined surfaces. Some polishers also use these stones to remove EDM scale. Can be used in a profiler or ultrasonic polisher.

5/32" x 5/32" x 4"

Style	Grit	Item#	EACH Prices	
			1-11	12-71
51	120	<b>415-0510</b>	<b>\$2.03</b>	<b>\$1.69</b>
52	220	<b>415-0520</b>	<b>2.03</b>	<b>1.69</b>
53	320	<b>415-0530</b>	<b>2.03</b>	<b>1.69</b>
54	400	<b>415-0540</b>	<b>2.03</b>	<b>1.69</b>
56	600	<b>415-0560</b>	<b>2.29</b>	<b>1.91</b>

1/4" x 1/8" x 6"

Style	Grit	Item#	EACH Prices	
			1-11	12-71
5101	120	<b>435-5101</b>	<b>\$3.15</b>	<b>\$2.62</b>
5201	220	<b>435-5201</b>	<b>3.15</b>	<b>2.62</b>
5301	320	<b>435-5301</b>	<b>3.27</b>	<b>2.72</b>
5401	400	<b>435-5401</b>	<b>3.27</b>	<b>2.72</b>
5601	600	<b>435-5601</b>	<b>3.77</b>	<b>3.14</b>

1/4" x 1/4" x 6"

Style	Grit	Item#	EACH Prices	
			1-11	12-71
5102	120	<b>435-5102</b>	<b>\$3.29</b>	<b>\$2.74</b>
5202	220	<b>435-5202</b>	<b>3.29</b>	<b>2.74</b>
5302	320	<b>435-5302</b>	<b>3.43</b>	<b>2.86</b>
5402	400	<b>435-5402</b>	<b>3.43</b>	<b>2.86</b>
5602	600	<b>435-5602</b>	<b>4.28</b>	<b>3.57</b>

1/2" x 1/8" x 6"

Style	Grit	Item#	EACH Prices	
			1-11	12-71
5103	120	<b>435-5103</b>	<b>\$3.43</b>	<b>\$2.86</b>
5203	220	<b>435-5203</b>	<b>3.43</b>	<b>2.86</b>
5303	320	<b>435-5303</b>	<b>3.65</b>	<b>3.04</b>
5403	400	<b>435-5403</b>	<b>3.65</b>	<b>3.04</b>
5603	600	<b>435-5603</b>	<b>4.53</b>	<b>3.77</b>

1/2" x 1/4" x 6"

Style	Grit	Item#	EACH Prices	
			1-11	12-71
5104	120	<b>435-5104</b>	<b>\$4.32</b>	<b>\$3.60</b>
5204	220	<b>435-5204</b>	<b>4.32</b>	<b>3.60</b>
5304	320	<b>435-5304</b>	<b>5.03</b>	<b>4.19</b>
5404	400	<b>435-5404</b>	<b>5.03</b>	<b>4.19</b>
5604	600	<b>435-5604</b>	<b>6.30</b>	<b>5.25</b>

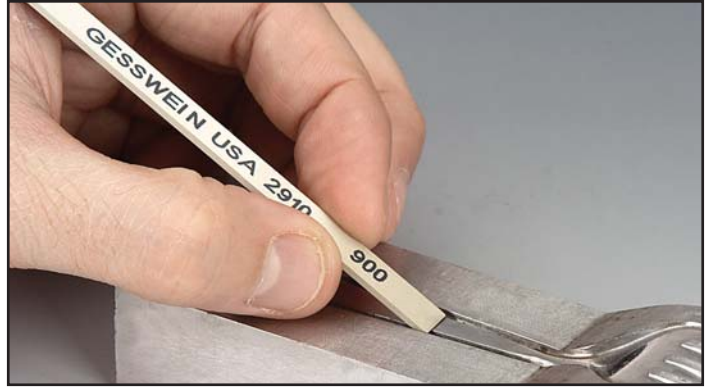

## Gesswein® Diemaker Stones

By far our most popular finishing stones, Diemaker Stones combine the characteristics of fast cutting and moderate breakdown. For general purpose stoning on hard and soft grades of mold steel and for prefinishing of aluminum, beryllium copper and kirksite. The precise grit size of medium-hard aluminum oxide is distributed throughout each stone. Can be used in a profiler or ultrasonic polisher.

$\frac{5}{32}$ " x  $\frac{5}{32}$ " x 4"



Style	Grit	Item#	EACH Prices	
			1-11	12-71
1	150	<b>415-0010</b>	<b>\$1.93</b>	<b>\$1.61</b>
2	220	<b>415-0020</b>	<b>1.93</b>	<b>1.61</b>
3	320	<b>415-0030</b>	<b>1.93</b>	<b>1.61</b>
4	400	<b>415-0040</b>	<b>1.93</b>	<b>1.61</b>
6	600	<b>415-0060</b>	<b>2.18</b>	<b>1.82</b>
9	900	<b>415-0090</b>	<b>2.18</b>	<b>1.82</b>

$\frac{1}{4}$ " x  $\frac{1}{16}$ " x 4"



Style	Grit	Item#	EACH Prices	
			1-11	12-71
2210	220	<b>405-2210</b>	<b>\$1.90</b>	<b>\$1.58</b>
2310	320	<b>405-2310</b>	<b>2.12</b>	<b>1.77</b>
2410	400	<b>405-2410</b>	<b>2.12</b>	<b>1.77</b>
2610	600	<b>405-2610</b>	<b>2.46</b>	<b>2.05</b>
2910	900	<b>405-2910</b>	<b>2.55</b>	<b>2.12</b>

$\frac{1}{4}$ " x  $\frac{1}{8}$ " x 6"



Style	Grit	Item#	EACH Prices	
			1-11	12-71
2101	150	<b>405-2101</b>	<b>\$2.77</b>	<b>\$2.31</b>
2201	220	<b>405-2201</b>	<b>2.77</b>	<b>2.31</b>
2301	320	<b>405-2301</b>	<b>3.10</b>	<b>2.58</b>
2401	400	<b>405-2401</b>	<b>3.10</b>	<b>2.58</b>
2601	600	<b>405-2601</b>	<b>3.50</b>	<b>2.92</b>
2901	900	<b>405-2901</b>	<b>3.66</b>	<b>3.05</b>

$\frac{1}{4}$ " x  $\frac{1}{4}$ " x 6"



Style	Grit	Item#	EACH Prices	
			1-11	12-71
2102	150	<b>405-2102</b>	<b>\$2.88</b>	<b>\$2.40</b>
2202	220	<b>405-2202</b>	<b>2.88</b>	<b>2.40</b>
2302	320	<b>405-2302</b>	<b>3.20</b>	<b>2.67</b>
2402	400	<b>405-2402</b>	<b>3.20</b>	<b>2.67</b>
2602	600	<b>405-2602</b>	<b>3.66</b>	<b>3.05</b>
2902	900	<b>405-2902</b>	<b>4.38</b>	<b>3.65</b>

$\frac{3}{8}$ " x  $\frac{3}{8}$ " x 6"



Style	Grit	Item#	EACH Prices	
			1-11	12-71
2108	150	<b>405-2108</b>	<b>\$4.16</b>	<b>\$3.47</b>
2208	220	<b>405-2208</b>	<b>4.16</b>	<b>3.47</b>
2308	320	<b>405-2308</b>	<b>4.60</b>	<b>3.83</b>
2408	400	<b>405-2408</b>	<b>4.60</b>	<b>3.83</b>
2608	600	<b>405-2608</b>	<b>6.23</b>	<b>5.19</b>
2908	900	<b>405-2908</b>	<b>7.89</b>	<b>6.57</b>

$\frac{1}{2}$ " x  $\frac{1}{16}$ " x 6"



Style	Grit	Item#	EACH Prices	
			1-11	12-71
2100	150	<b>405-2100</b>	<b>\$3.13</b>	<b>\$2.61</b>
2200	220	<b>405-2200</b>	<b>3.13</b>	<b>2.61</b>
2300	320	<b>405-2300</b>	<b>3.49</b>	<b>2.91</b>
2400	400	<b>405-2400</b>	<b>3.49</b>	<b>2.91</b>
2600	600	<b>405-2600</b>	<b>4.00</b>	<b>3.33</b>
2900	900	<b>405-2900</b>	<b>4.47</b>	<b>3.72</b>

$\frac{1}{2}$ " x  $\frac{1}{8}$ " x 6"



Style	Grit	Item#	EACH Prices	
			1-11	12-71
2103	150	<b>405-2103</b>	<b>\$3.29</b>	<b>\$2.74</b>
2203	220	<b>405-2203</b>	<b>3.29</b>	<b>2.74</b>
2303	320	<b>405-2303</b>	<b>3.57</b>	<b>2.97</b>
2403	400	<b>405-2403</b>	<b>3.57</b>	<b>2.97</b>
2603	600	<b>405-2603</b>	<b>4.19</b>	<b>3.49</b>
2903	900	<b>405-2903</b>	<b>4.69</b>	<b>3.91</b>

$\frac{1}{2}$ " x  $\frac{1}{4}$ " x 6"



Style	Grit	Item#	EACH Prices	
			1-11	12-71
2104	150	<b>405-2104</b>	<b>\$3.79</b>	<b>\$3.16</b>
2204	220	<b>405-2204</b>	<b>3.79</b>	<b>3.16</b>
2304	320	<b>405-2304</b>	<b>4.39</b>	<b>3.66</b>
2404	400	<b>405-2404</b>	<b>4.39</b>	<b>3.66</b>
2604	600	<b>405-2604</b>	<b>5.53</b>	<b>4.61</b>
2904	900	<b>405-2904</b>	<b>6.57</b>	<b>5.47</b>

$\frac{1}{2}$ " x  $\frac{1}{2}$ " x 6"



Style	Grit	Item#	EACH Prices	
			1-5	6-71
2105	150	<b>405-2105</b>	<b>\$5.04</b>	<b>\$4.20</b>
2205	220	<b>405-2205</b>	<b>5.04</b>	<b>4.20</b>
2305	320	<b>405-2305</b>	<b>7.30</b>	<b>6.08</b>
2405	400	<b>405-2405</b>	<b>7.30</b>	<b>6.08</b>
2605	600	<b>405-2605</b>	<b>9.47</b>	<b>7.89</b>
2905	900	<b>405-2905</b>	<b>9.85</b>	<b>8.21</b>



**Additional  
Quantity Discounts  
On All Finishing Stones!**

Discounts off one-piece prices;  
mixed orders do not qualify.

72-143	<b>25% off</b>
144+	<b>33% off</b>



3/4" x 1/4" x 6"



Style	Grit	Item#	EACH Prices	
			1-5	6-71
2109	150	<b>405-2109</b>	<b>\$4.63</b>	<b>\$3.86</b>
2209	220	<b>405-2209</b>	<b>4.63</b>	<b>3.86</b>
2309	320	<b>405-2309</b>	<b>6.16</b>	<b>5.13</b>
2409	400	<b>405-2409</b>	<b>6.16</b>	<b>5.13</b>
2609	600	<b>405-2609</b>	<b>8.15</b>	<b>6.79</b>
2909	900	<b>405-2909</b>	<b>9.67</b>	<b>8.06</b>

1" x 1/8" x 6"



Style	Grit	Item#	EACH Prices	
			1-11	12-71
2311	320	<b>405-2311</b>	<b>\$6.09</b>	<b>\$5.07</b>
2411	400	<b>405-2411</b>	<b>6.09</b>	<b>5.07</b>
2611	600	<b>405-2611</b>	<b>8.15</b>	<b>6.79</b>

1" x 1/4" x 6"



Style	Grit	Item#	EACH Prices	
			1-5	6-71
2312	320	<b>405-2312</b>	<b>\$7.25</b>	<b>\$6.04</b>
2412	400	<b>405-2412</b>	<b>7.25</b>	<b>6.04</b>
2612	600	<b>405-2612</b>	<b>9.69</b>	<b>8.07</b>

1" x 1/2" x 6"



Style	Grit	Item#	EACH Prices	
			1-5	6-71
2107	150	<b>405-2107</b>	<b>\$6.99</b>	<b>\$5.82</b>
2207	220	<b>405-2207</b>	<b>6.99</b>	<b>5.82</b>
2307	320	<b>405-2307</b>	<b>11.00</b>	<b>9.17</b>
2407	400	<b>405-2407</b>	<b>11.00</b>	<b>9.17</b>
2607	600	<b>405-2607</b>	<b>14.49</b>	<b>12.07</b>
2907	900	<b>405-2907</b>	<b>16.80</b>	<b>14.00</b>

1" x 1" x 6"



Style	Grit	Item#	EACH Prices	
			1-5	6-71
2106	150	<b>405-2106</b>	<b>\$11.98</b>	<b>\$9.98</b>
2206	220	<b>405-2206</b>	<b>11.98</b>	<b>9.98</b>
2306	320	<b>405-2306</b>	<b>16.38</b>	<b>13.65</b>
2406	400	<b>405-2406</b>	<b>16.38</b>	<b>13.65</b>
2606	600	<b>405-2606</b>	<b>24.24</b>	<b>20.20</b>

Round, 1/4" x 6"



Style	Grit	Item#	EACH Prices	
			1-11	12-71
3102	150	<b>405-3102</b>	<b>\$5.52</b>	<b>\$4.60</b>
3202	220	<b>405-3202</b>	<b>5.52</b>	<b>4.60</b>
3302	320	<b>405-3302</b>	<b>7.26</b>	<b>6.05</b>
3402	400	<b>405-3402</b>	<b>7.26</b>	<b>6.05</b>
3602	600	<b>405-3602</b>	<b>9.99</b>	<b>8.32</b>
3902	900	<b>405-3902</b>	<b>11.66</b>	<b>9.72</b>

Round, 3/8" x 6"



Style	Grit	Item#	EACH Prices	
			1-11	12-71
3108	150	<b>405-3108</b>	<b>\$6.79</b>	<b>\$5.66</b>
3208	220	<b>405-3208</b>	<b>6.79</b>	<b>5.66</b>
3308	320	<b>405-3308</b>	<b>9.07</b>	<b>7.56</b>
3408	400	<b>405-3408</b>	<b>9.07</b>	<b>7.56</b>
3608	600	<b>405-3608</b>	<b>10.73</b>	<b>8.94</b>

Round, 1/2" x 6"

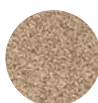

Style	Grit	Item#	EACH Prices	
			1-5	6-71
3105	150	<b>405-3105</b>	<b>\$7.77</b>	<b>\$6.47</b>
3205	220	<b>405-3205</b>	<b>7.77</b>	<b>6.47</b>
3305	320	<b>405-3305</b>	<b>10.26</b>	<b>8.55</b>
3405	400	<b>405-3405</b>	<b>10.26</b>	<b>8.55</b>
3605	600	<b>405-3605</b>	<b>13.73</b>	<b>11.44</b>

Triangular, 1/4" x 6"



Style	Grit	Item#	EACH Prices	
			1-11	12-71
21T2	150	<b>405-2192</b>	<b>\$3.23</b>	<b>\$2.69</b>
22T2	220	<b>405-2292</b>	<b>3.23</b>	<b>2.69</b>
23T2	320	<b>405-2392</b>	<b>3.73</b>	<b>3.11</b>
24T2	400	<b>405-2492</b>	<b>3.73</b>	<b>3.11</b>

Triangular, 3/8" x 6"



Style	Grit	Item#	EACH Prices	
			1-11	12-71
21T8	150	<b>405-2198</b>	<b>\$4.57</b>	<b>\$3.81</b>
22T8	220	<b>405-2298</b>	<b>4.57</b>	<b>3.81</b>
23T8	320	<b>405-2398</b>	<b>4.81</b>	<b>4.01</b>
24T8	400	<b>405-2498</b>	<b>4.81</b>	<b>4.01</b>



## Additional Quantity Discounts On All Finishing Stones!

Discounts off one-piece prices; mixed orders do not qualify.

72-143	<b>25% off</b>
144+	<b>33% off</b>

### Gesswein® Moldmaker Plus Stones

A premium complement to the Moldmaker Series. These general purpose, premium-grade green silicon carbide stones are medium-hard with slower breakdown characteristics. A good choice for stoning contours and radii. Produces a silky matte finish on all prehardened tool steels, from 28Rc SAE 4130 through 60Rc A2 and M2. Can also be used to rough out aluminum, beryllium copper and kirkSITE.

1/2" x 1/8" x 6"



Style	Grit	Item#	EACH Prices	
			1-11	12-71
1103P	100	<b>412-1103</b>	<b>\$3.45</b>	<b>\$2.87</b>
1153P	150	<b>412-1153</b>	<b>3.45</b>	<b>2.87</b>
1203P	220	<b>412-1203</b>	<b>3.45</b>	<b>2.87</b>
1303P	320	<b>412-1303</b>	<b>4.05</b>	<b>3.37</b>
1403P	400	<b>412-1403</b>	<b>4.05</b>	<b>3.37</b>
1603P	600	<b>412-1603</b>	<b>5.15</b>	<b>4.29</b>
1803P	800	<b>412-1803</b>	<b>5.68</b>	<b>4.73</b>
2003P	1200	<b>412-2003</b>	<b>6.80</b>	<b>5.67</b>

5/32" x 5/32" x 4"



Style	Grit	Item#	EACH Prices	
			1-11	12-71
15P	150	<b>415-1015</b>	<b>\$1.89</b>	<b>\$1.57</b>
20P	220	<b>415-1020</b>	<b>1.89</b>	<b>1.57</b>
30P	320	<b>415-1030</b>	<b>1.89</b>	<b>1.57</b>
40P	400	<b>415-1040</b>	<b>1.89</b>	<b>1.57</b>
60P	600	<b>415-1060</b>	<b>2.14</b>	<b>1.78</b>
80P	800	<b>415-1080</b>	<b>2.36</b>	<b>1.97</b>
200P	1200	<b>415-1200</b>	<b>2.71</b>	<b>2.26</b>

1/2" x 1/4" x 6"



Style	Grit	Item#	EACH Prices	
			1-11	12-71
1104P	100	<b>412-1104</b>	<b>\$4.15</b>	<b>\$3.46</b>
1154P	150	<b>412-1154</b>	<b>4.15</b>	<b>3.46</b>
1204P	220	<b>412-1204</b>	<b>4.15</b>	<b>3.46</b>
1304P	320	<b>412-1304</b>	<b>4.95</b>	<b>4.12</b>
1404P	400	<b>412-1404</b>	<b>4.95</b>	<b>4.12</b>
1604P	600	<b>412-1604</b>	<b>6.44</b>	<b>5.37</b>
1804P	800	<b>412-1804</b>	<b>7.09</b>	<b>5.91</b>
2004P	1200	<b>412-2004</b>	<b>8.53</b>	<b>7.11</b>

1/4" x 1/8" x 6"



Style	Grit	Item#	EACH Prices	
			1-11	12-71
1101P	100	<b>412-1101</b>	<b>\$3.02</b>	<b>\$2.52</b>
1151P	150	<b>412-1151</b>	<b>3.02</b>	<b>2.52</b>
1201P	220	<b>412-1201</b>	<b>3.02</b>	<b>2.52</b>
1301P	320	<b>412-1301</b>	<b>3.57</b>	<b>2.97</b>
1401P	400	<b>412-1401</b>	<b>3.57</b>	<b>2.97</b>
1601P	600	<b>412-1601</b>	<b>4.39</b>	<b>3.66</b>
1801P	800	<b>412-1801</b>	<b>4.86</b>	<b>4.05</b>
2001P	1200	<b>412-2001</b>	<b>5.81</b>	<b>4.84</b>

1/2" x 1/2" x 6"



Style	Grit	Item#	EACH Prices	
			1-5	6-71
1105P	100	<b>412-1105</b>	<b>\$6.63</b>	<b>\$5.52</b>
1155P	150	<b>412-1155</b>	<b>6.63</b>	<b>5.52</b>
1205P	220	<b>412-1205</b>	<b>6.63</b>	<b>5.52</b>
1305P	320	<b>412-1305</b>	<b>7.85</b>	<b>6.54</b>
1405P	400	<b>412-1405</b>	<b>7.85</b>	<b>6.54</b>
1605P	600	<b>412-1605</b>	<b>12.74</b>	<b>10.62</b>
1805P	800	<b>412-1805</b>	<b>14.02</b>	<b>11.68</b>
2005P	1200	<b>412-2005</b>	<b>16.79</b>	<b>13.99</b>

1/4" x 1/4" x 6"



Style	Grit	Item#	EACH Prices	
			1-11	12-71
1102P	100	<b>412-1102</b>	<b>\$3.08</b>	<b>\$2.57</b>
1152P	150	<b>412-1152</b>	<b>3.08</b>	<b>2.57</b>
1202P	220	<b>412-1202</b>	<b>3.08</b>	<b>2.57</b>
1302P	320	<b>412-1302</b>	<b>3.64</b>	<b>3.03</b>
1402P	400	<b>412-1402</b>	<b>3.64</b>	<b>3.03</b>
1602P	600	<b>412-1602</b>	<b>4.48</b>	<b>3.73</b>
1802P	800	<b>412-1802</b>	<b>4.95</b>	<b>4.12</b>
2002P	1200	<b>412-2002</b>	<b>5.93</b>	<b>4.94</b>

1" x 1" x 6"

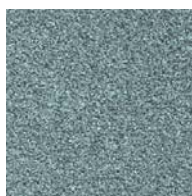

Style	Grit	Item#	EACH Prices	
			1-5	6-71
1106P	100	<b>412-1106</b>	<b>\$13.89</b>	<b>\$11.57</b>
1156P	150	<b>412-1156</b>	<b>13.89</b>	<b>11.57</b>
1206P	220	<b>412-1206</b>	<b>13.89</b>	<b>11.57</b>
1306P	320	<b>412-1306</b>	<b>18.52</b>	<b>15.43</b>

**Additional  
Quantity Discounts  
On All Finishing Stones!**

Discounts off one-piece prices;  
mixed orders do not qualify.

72-143	<b>25% off</b>
144+	<b>33% off</b>

**Gesswein® Moldmaker Stones**

Our Moldmaker Stones are made of silicon carbide abrasive with a specially formulated bonding agent that permits rapid breakdown to inhibit loading. Ideal for blending, radii detail or following contours. Use on all types of steels and for roughing out nonferrous metals. Can be used by hand or in a profiler. Available in 4" and 6" lengths.

$\frac{1}{4}$ " x  $\frac{1}{16}$ " x 4"

Style	Grit	Item#	EACH Prices	
			1-11	12-71
200	220	<b>410-0200</b>	<b>\$2.02</b>	<b>\$1.68</b>
300	320	<b>410-0300</b>	<b>2.37</b>	<b>1.97</b>
400	400	<b>410-0400</b>	<b>2.37</b>	<b>1.97</b>
600	600	<b>410-0600</b>	<b>2.95</b>	<b>2.46</b>

$\frac{1}{4}$ " x  $\frac{1}{8}$ " x 4"

Style	Grit	Item#	EACH Prices	
			1-11	12-71
201	220	<b>410-0201</b>	<b>\$2.05</b>	<b>\$1.71</b>
301	320	<b>410-0301</b>	<b>2.42</b>	<b>2.02</b>
401	400	<b>410-0401</b>	<b>2.42</b>	<b>2.02</b>
601	600	<b>410-0601</b>	<b>3.00</b>	<b>2.50</b>

$\frac{1}{4}$ " x  $\frac{1}{8}$ " x 6"

Style	Grit	Item#	EACH Prices	
			1-11	12-71
1201	220	<b>410-1201</b>	<b>\$2.76</b>	<b>\$2.30</b>
1301	320	<b>410-1301</b>	<b>3.23</b>	<b>2.69</b>
1401	400	<b>410-1401</b>	<b>3.23</b>	<b>2.69</b>
1601	600	<b>410-1601</b>	<b>3.99</b>	<b>3.32</b>

$\frac{1}{4}$ " x  $\frac{1}{4}$ " x 4"

Style	Grit	Item#	EACH Prices	
			1-11	12-71
202	220	<b>410-0202</b>	<b>\$2.11</b>	<b>\$1.76</b>
302	320	<b>410-0302</b>	<b>2.48</b>	<b>2.07</b>
402	400	<b>410-0402</b>	<b>2.48</b>	<b>2.07</b>
602	600	<b>410-0602</b>	<b>3.06</b>	<b>2.55</b>

$\frac{1}{4}$ " x  $\frac{1}{4}$ " x 6"

Style	Grit	Item#	EACH Prices	
			1-11	12-71
1202	220	<b>410-1202</b>	<b>\$2.80</b>	<b>\$2.33</b>
1302	320	<b>410-1302</b>	<b>3.31</b>	<b>2.76</b>
1402	400	<b>410-1402</b>	<b>3.31</b>	<b>2.76</b>
1602	600	<b>410-1602</b>	<b>4.08</b>	<b>3.40</b>

$\frac{1}{2}$ " x  $\frac{1}{8}$ " x 4"

Style	Grit	Item#	EACH Prices	
			1-11	12-71
203	220	<b>410-0203</b>	<b>\$2.34</b>	<b>\$1.95</b>
303	320	<b>410-0303</b>	<b>2.80</b>	<b>2.33</b>
403	400	<b>410-0403</b>	<b>2.80</b>	<b>2.33</b>
603	600	<b>410-0603</b>	<b>3.50</b>	<b>2.92</b>



$\frac{1}{2}$ " x  $\frac{1}{8}$ " x 6"

Style	Grit	Item#	EACH Prices	
			1-11	12-71
1203	220	<b>410-1203</b>	<b>\$3.13</b>	<b>\$2.61</b>
1303	320	<b>410-1303</b>	<b>3.71</b>	<b>3.09</b>
1403	400	<b>410-1403</b>	<b>3.71</b>	<b>3.09</b>
1603	600	<b>410-1603</b>	<b>4.67</b>	<b>3.89</b>

$\frac{1}{2}$ " x  $\frac{1}{4}$ " x 4"

Style	Grit	Item#	EACH Prices	
			1-11	12-71
204	220	<b>410-0204</b>	<b>\$2.67</b>	<b>\$2.22</b>
304	320	<b>410-0304</b>	<b>3.66</b>	<b>3.05</b>
404	400	<b>410-0404</b>	<b>3.66</b>	<b>3.05</b>
604	600	<b>410-0604</b>	<b>4.63</b>	<b>3.86</b>

$\frac{1}{2}$ " x  $\frac{1}{4}$ " x 6"

Style	Grit	Item#	EACH Prices	
			1-11	12-71
1204	220	<b>410-1204</b>	<b>\$3.77</b>	<b>\$3.14</b>
1304	320	<b>410-1304</b>	<b>4.48</b>	<b>3.73</b>
1404	400	<b>410-1404</b>	<b>4.48</b>	<b>3.73</b>
1604	600	<b>410-1604</b>	<b>5.88</b>	<b>4.90</b>

$\frac{1}{2}$ " x  $\frac{1}{2}$ " x 4"

Style	Grit	Item#	EACH Prices	
			1-5	6-71
205	220	<b>410-0205</b>	<b>\$4.11</b>	<b>\$3.42</b>
305	320	<b>410-0305</b>	<b>5.65</b>	<b>4.71</b>
405	400	<b>410-0405</b>	<b>5.65</b>	<b>4.71</b>
605	600	<b>410-0605</b>	<b>7.61</b>	<b>6.34</b>

$\frac{1}{2}$ " x  $\frac{1}{2}$ " x 6"

Style	Grit	Item#	EACH Prices	
			1-5	6-71
1205	220	<b>410-1205</b>	<b>\$6.02</b>	<b>\$5.02</b>
1305	320	<b>410-1305</b>	<b>7.13</b>	<b>5.94</b>
1405	400	<b>410-1405</b>	<b>7.13</b>	<b>5.94</b>
1605	600	<b>410-1605</b>	<b>11.58</b>	<b>9.65</b>

1" x 1" x 6"

Style	Grit	Item#	EACH Prices	
			1-5	6-71
1206	220	<b>410-1206</b>	<b>\$12.66</b>	<b>\$10.55</b>
1306	320	<b>410-1306</b>	<b>16.91</b>	<b>14.09</b>
1406	400	<b>410-1406</b>	<b>16.91</b>	<b>14.09</b>
1606	600	<b>410-1606</b>	<b>25.13</b>	<b>20.94</b>





## Gesswein® Rough Out Stones

Large, coarse, relatively soft stones containing aluminum oxide, Rough Out Stones cut fast with rapid breakdown. Use to quickly remove rough scratches and machine tool marks or for “hogging” out large amounts of material prior to the finishing process. A good choice for roughing surfaces of larger molds and dies.

1/4" x 1/4" x 8"	Style	Grit	Item#	EACH Prices	
				1-11	12-71
	X8002	100	<b>430-8002</b>	<b>\$2.35</b>	<b>\$1.96</b>

1" x 1/4" x 8"	Style	Grit	Item#	EACH Prices	
				1-11	12-71
	X8080	80	<b>430-8080</b>	<b>\$5.33</b>	<b>\$4.44</b>
	X8100	100	<b>430-8100</b>	<b>5.33</b>	<b>4.44</b>
	X8150	150	<b>430-8150</b>	<b>5.33</b>	<b>4.44</b>
	X8200	220	<b>430-8200</b>	<b>5.33</b>	<b>4.44</b>

1" x 1/2" x 8"	Style	Grit	Item#	EACH Prices	
				1-11	12-71
	X8081	80	<b>430-8081</b>	<b>\$6.58</b>	<b>\$5.48</b>
	X8101	100	<b>430-8101</b>	<b>6.58</b>	<b>5.48</b>
	X8151	150	<b>430-8151</b>	<b>6.58</b>	<b>5.48</b>
	X8201	220	<b>430-8201</b>	<b>6.58</b>	<b>5.48</b>

1 1/2" x 3/4" x 8"	Style	Grit	Item#	EACH Prices	
				1-11	12-71
	X8082	80	<b>430-8082</b>	<b>\$10.59</b>	<b>\$8.82</b>
	X8102	100	<b>430-8102</b>	<b>10.59</b>	<b>8.82</b>
	X8152	150	<b>430-8152</b>	<b>10.59</b>	<b>8.82</b>
	X8202	220	<b>430-8202</b>	<b>10.59</b>	<b>8.82</b>

## Gesswein® White Polishing Stones

These finishing stones contain aluminum oxide and can be best described as soft and “chalk-like.” White Polishing Stones break down rapidly and are used to remove light scratches from metal surfaces. Excellent for final finishing prior to using diamond compound. Best used for hand stoning. All are 800 grit.

5/32" x 5/32" x 4"	Style	Grit	Item#	EACH Prices	
				1-11	12-71
	8	800	<b>415-0080</b>	<b>\$2.29</b>	<b>\$1.91</b>

1/4" x 1/8" x 4"	Style	Grit	Item#	EACH Prices	
				1-11	12-71
	801	800	<b>445-0801</b>	<b>\$3.06</b>	<b>\$2.55</b>

1/4" x 1/4" x 4"	Style	Grit	Item#	EACH Prices	
				1-11	12-71
	802	800	<b>445-0802</b>	<b>\$3.22</b>	<b>\$2.68</b>

1/2" x 1/8" x 4"	Style	Grit	Item#	EACH Prices	
				1-11	12-71
	803	800	<b>445-0803</b>	<b>\$3.54</b>	<b>\$2.95</b>

1/2" x 1/4" x 4"	Style	Grit	Item#	EACH Prices	
				1-11	12-71
	804	800	<b>445-0804</b>	<b>\$4.99</b>	<b>\$4.16</b>

1/2" x 1/2" x 4"	Style	Grit	Item#	EACH Prices	
				1-5	6-71
	805	800	<b>445-0805</b>	<b>\$8.72</b>	<b>\$7.27</b>

### Additional Quantity Discounts On All Finishing Stones!

Discounts off one-piece prices;  
mixed orders do not qualify.

72-143	<b>25% off</b>
144+	<b>33% off</b>



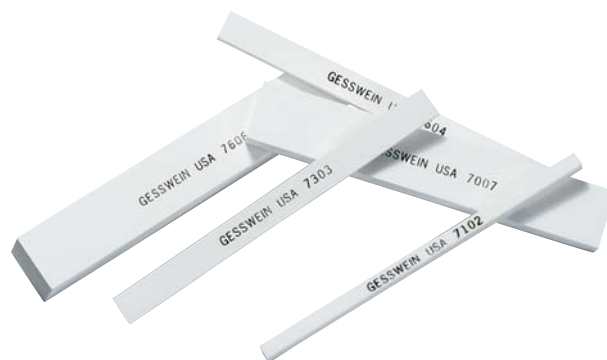



**Gesswein® Super Fine Stones**

Super Fine Stones contain levigated (finely powdered) alumina and are one of our softest stones for finishing steel surfaces. They break down very rapidly and do not scratch. Super Fine Stones may be used to produce a final finish or to prepare surfaces for polishing with diamond compound. An excellent choice for P20 and 420SS. All are 1200 grit and not quite as soft as our Ultra-Soft Stones.

5/32" x 5/32" x 4"	Style	Grit	Item#	EACH Prices	
				1-11	12-71
	12	1200	<b>415-0120</b>	<b>\$2.29</b>	<b>\$1.91</b>

1/4" x 1/8" x 6"	Style	Grit	Item#	EACH Prices	
				1-11	12-71
	9001	1200	<b>440-9001</b>	<b>\$3.61</b>	<b>\$3.01</b>

1/4" x 1/4" x 6"	Style	Grit	Item#	EACH Prices	
				1-11	12-71
	9002	1200	<b>440-9002</b>	<b>\$4.17</b>	<b>\$3.47</b>

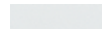
1/2" x 1/8" x 6"	Style	Grit	Item#	EACH Prices	
				1-11	12-71
	9003	1200	<b>440-9003</b>	<b>\$4.76</b>	<b>\$3.97</b>

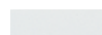
1/2" x 1/4" x 6"	Style	Grit	Item#	EACH Prices	
				1-11	12-71
	9004	1200	<b>440-9004</b>	<b>\$5.74</b>	<b>\$4.78</b>

**Gesswein® Ultra-Soft Stones**

Ultra-Soft Stones contain aluminum oxide bonded with an extra-soft bonding agent and are formulated to break down rapidly (more quickly than our Moldmaker Stones). For use on soft metals, including aluminum, stainless steel, brass, beryllium and kirksite. These stones are fast-cutting and absolutely nonloading. They can be easily shaped for finishing contours.

1/4" x 1/4" x 6"	Style	Grit	Item#	EACH Prices	
				1-11	12-71
	7102	120	<b>450-7102</b>	<b>\$3.03</b>	<b>\$2.52</b>
	7302	320	<b>450-7302</b>	<b>3.43</b>	<b>2.86</b>
	7602	600	<b>450-7602</b>	<b>4.17</b>	<b>3.47</b>
	7002	1200	<b>450-7002</b>	<b>4.32</b>	<b>3.60</b>

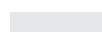
1/2" x 1/8" x 6"	Style	Grit	Item#	EACH Prices	
				1-11	12-71
	7103	120	<b>450-7103</b>	<b>\$3.45</b>	<b>\$2.87</b>
	7303	320	<b>450-7303</b>	<b>3.66</b>	<b>3.05</b>
	7603	600	<b>450-7603</b>	<b>4.40</b>	<b>3.67</b>
	7003	1200	<b>450-7003</b>	<b>4.78</b>	<b>3.98</b>

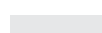
1/2" x 1/4" x 6"	Style	Grit	Item#	EACH Prices	
				1-11	12-71
	7104	120	<b>450-7104</b>	<b>\$3.98</b>	<b>\$3.32</b>
	7304	320	<b>450-7304</b>	<b>4.61</b>	<b>3.84</b>
	7604	600	<b>450-7604</b>	<b>6.18</b>	<b>5.15</b>
	7004	1200	<b>450-7004</b>	<b>6.37</b>	<b>5.31</b>

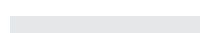
1" x 1/2" x 6"	Style	Grit	Item#	EACH Prices	
				1-5	6-71
	7107	120	<b>450-7107</b>	<b>\$7.46</b>	<b>\$6.22</b>
	7307	320	<b>450-7307</b>	<b>11.51</b>	<b>9.59</b>
	7607	600	<b>450-7607</b>	<b>16.49</b>	<b>13.74</b>
	7007	1200	<b>450-7007</b>	<b>16.81</b>	<b>14.01</b>

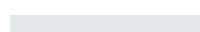
1" x 1" x 6"	Style	Grit	Item#	EACH Prices	
				1-5	6-71
	7106	120	<b>450-7106</b>	<b>\$12.36</b>	<b>\$10.30</b>
	7306	320	<b>450-7306</b>	<b>17.20</b>	<b>14.33</b>
	7606	600	<b>450-7606</b>	<b>26.28</b>	<b>21.90</b>
	7006	1200	<b>450-7006</b>	<b>26.74</b>	<b>22.28</b>

**Additional  
Quantity Discounts  
On All Finishing Stones!**

Discounts off one-piece prices; mixed orders do not qualify.

72-143	<b>25% off</b>
144+	<b>33% off</b>



## Gesswein® Pencil Stones

A selection of our most popular finishing stones are available 4" long x 5/32" square, making them convenient for stoning small or intricate areas. Shorter length helps prevent wasteful breakage. Use with Pencil Stone Holders shown on the next page.

RA 5/32" x 5/32" x 4"	Style	Grit	Item#	EACH Prices	
				1-11	12-71
	RA41	180	<b>415-0410</b>	<b>\$2.44</b>	<b>\$2.03</b>
	RA42	220	<b>415-0420</b>	<b>2.44</b>	<b>2.03</b>
	RA43	320	<b>415-0430</b>	<b>2.57</b>	<b>2.14</b>
	RA44	400	<b>415-0440</b>	<b>2.57</b>	<b>2.14</b>
	RA46	600	<b>415-0460</b>	<b>2.92</b>	<b>2.43</b>

EDM Blue 5/32" x 5/32" x 4"	Style	Grit	Item#	EACH Prices	
				1-11	12-71
	61B	120	<b>415-6010</b>	<b>\$2.03</b>	<b>\$1.69</b>
	62B	180	<b>415-6020</b>	<b>2.03</b>	<b>1.69</b>
	622B	220	<b>415-6022</b>	<b>2.03</b>	<b>1.69</b>
	63B	320	<b>415-6030</b>	<b>2.03</b>	<b>1.69</b>
	64B	400	<b>415-6040</b>	<b>2.03</b>	<b>1.69</b>
	66B	600	<b>415-6060</b>	<b>2.29</b>	<b>1.91</b>

EDM 5/32" x 5/32" x 4"	Style	Grit	Item#	EACH Prices	
				1-11	12-71
	61	120	<b>415-0610</b>	<b>\$2.03</b>	<b>\$1.69</b>
	62	180	<b>415-0620</b>	<b>2.03</b>	<b>1.69</b>
	622	220	<b>415-0622</b>	<b>2.03</b>	<b>1.69</b>
	63	320	<b>415-0630</b>	<b>2.03</b>	<b>1.69</b>
	64	400	<b>415-0640</b>	<b>2.03</b>	<b>1.69</b>
	66	600	<b>415-0660</b>	<b>2.29</b>	<b>1.91</b>

GP 5/32" x 5/32" x 4"	Style	Grit	Item#	EACH Prices	
				1-11	12-71
	15G	150	<b>415-0315</b>	<b>\$2.03</b>	<b>\$1.69</b>
	18G	180	<b>415-0318</b>	<b>2.03</b>	<b>1.69</b>
	22G	220	<b>415-0320</b>	<b>2.03</b>	<b>1.69</b>
	32G	320	<b>415-0330</b>	<b>2.03</b>	<b>1.69</b>
	42G	400	<b>415-0340</b>	<b>2.03</b>	<b>1.69</b>
	60G	600	<b>415-0360</b>	<b>2.29</b>	<b>1.91</b>

Premium White 5/32" x 5/32" x 4"	Style	Grit	Item#	EACH Prices	
				1-11	12-71
	2W	220	<b>415-5002</b>	<b>\$2.24</b>	<b>\$1.87</b>
	3W	320	<b>415-5003</b>	<b>2.24</b>	<b>1.87</b>
	4W	400	<b>415-5004</b>	<b>2.24</b>	<b>1.87</b>
	6W	600	<b>415-5006</b>	<b>2.52</b>	<b>2.10</b>

## Oil-Treated

5/32" x 5/32" x 4"	Style	Grit	Item#	EACH Prices	
				1-11	12-71
	51	120	<b>415-0510</b>	<b>\$2.03</b>	<b>\$1.69</b>
	52	220	<b>415-0520</b>	<b>2.03</b>	<b>1.69</b>
	53	320	<b>415-0530</b>	<b>2.03</b>	<b>1.69</b>
	54	400	<b>415-0540</b>	<b>2.03</b>	<b>1.69</b>
	56	600	<b>415-0560</b>	<b>2.29</b>	<b>1.91</b>

## Diemaker

5/32" x 5/32" x 4"	Style	Grit	Item#	EACH Prices	
				1-11	12-71
	1	150	<b>415-0010</b>	<b>\$1.93</b>	<b>\$1.61</b>
	2	220	<b>415-0020</b>	<b>1.93</b>	<b>1.61</b>
	3	320	<b>415-0030</b>	<b>1.93</b>	<b>1.61</b>
	4	400	<b>415-0040</b>	<b>1.93</b>	<b>1.61</b>
	6	600	<b>415-0060</b>	<b>2.18</b>	<b>1.82</b>
	9	900	<b>415-0090</b>	<b>2.18</b>	<b>1.82</b>

## Moldmaker Plus

5/32" x 5/32" x 4"	Style	Grit	Item#	EACH Prices	
				1-11	12-71
	15P	150	<b>415-1015</b>	<b>\$1.89</b>	<b>\$1.57</b>
	20P	220	<b>415-1020</b>	<b>1.89</b>	<b>1.57</b>
	30P	320	<b>415-1030</b>	<b>1.89</b>	<b>1.57</b>
	40P	400	<b>415-1040</b>	<b>1.89</b>	<b>1.57</b>
	60P	600	<b>415-1060</b>	<b>2.14</b>	<b>1.78</b>
	80P	800	<b>415-1080</b>	<b>2.36</b>	<b>1.97</b>
	200P	1200	<b>415-1200</b>	<b>2.71</b>	<b>2.26</b>

## White Polishing

5/32" x 5/32" x 4"	Style	Grit	Item#	EACH Prices	
				1-11	12-71
	8	800	<b>415-0080</b>	<b>\$2.29</b>	<b>\$1.91</b>

## Super Fine

5/32" x 5/32" x 4"	Style	Grit	Item#	EACH Prices	
				1-11	12-71
	12	1200	<b>415-0120</b>	<b>\$2.29</b>	<b>\$1.91</b>

## Medium India®

5/32" x 5/32" x 4"	Style	Grit	Item#	EACH Prices	
				1-11	12-71
	10	240	<b>415-0100</b>	<b>\$2.40</b>	<b>\$2.00</b>

### Additional Quantity Discounts On All Finishing Stones!

Discounts off one-piece prices;  
mixed orders do not qualify.

72-143	<b>25% off</b>
144+	<b>33% off</b>

**A Gesswein® Pencil Stone Set III**

Contains every pencil stone listed on the previous page. A great assortment to keep handy for polishing intricate or hard-to-reach areas such as slots and ribs. Comes complete with Pencil Stone Holder #403-0050 and a free sample of Gesswein Stoning Oil.

Description	Item#	Each
48-Piece Pencil Stone Set	<b>415-1028</b>	<b>\$69.95</b>

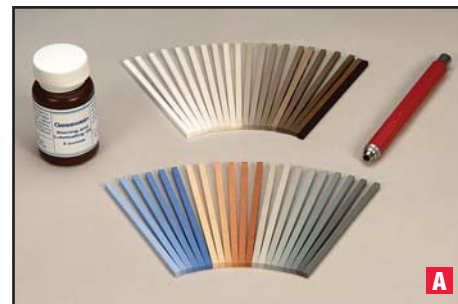

**B Pencil Stone Holder**

Push-button holder for easy loading. Holds 5/32" square stones. Measures 5 1/4" long.

Description	Item#	EACH Prices		
		1-2	3-11	12+
<b>B.</b> Pencil Stone Holder	<b>403-0050</b>	<b>\$5.45</b>	<b>\$5.12</b>	<b>\$4.63</b>
Replacement Collet	403-0085	3.25	-	-



**C, D Gesswein® Stoning and Lubricating Oil**

This special lubricant was developed for the mold and die finisher. It is economical and practically odorless, and it evaporates slowly. Recommended for fast cutting and for finishing operations. Helps prevent loading. Lets stones cut better and more freely so they produce a bright, smooth surface. Eliminates the need for hazardous kerosene. For use with diamond tools where lubrication is suggested. Viscosity: 38/45.

Description	Item#	Each
<b>C.</b> Pint (wide-mouth glass container)	<b>800-0100</b>	<b>\$8.95</b>
<b>D.</b> Gallon	<b>800-0110</b>	<b>20.75</b>



**E, F Syringe Dispensers**

Plastic syringes with 18-gauge stainless steel needles for pinpoint delivery of stoning oil to the exact place you want. Plunger works smoothly and slides evenly to prevent accidental flooding and sputtering. Constructed of polyethylene and polypropylene. Available in two sizes: 5 and 10cc. Each includes tip sheath and cover. Sold in packages of six.

Size	Item#	PKG. of 6	
		1-3	4+
<b>E.</b> 5cc	<b>811-2450</b>	<b>\$7.95</b>	<b>\$6.36</b>
<b>F.</b> 10cc	<b>811-2451</b>	<b>9.95</b>	<b>7.96</b>



**G Plastic Spray-Pump Bottle**

Use to dispense stoning oil, cleaning solution and more. Capacity: 4 fl. oz.

Description	Item#	EACH Prices	
		1-2	3+
Plastic Spray-Pump Bottle	<b>811-2460</b>	<b>\$2.15</b>	<b>\$1.94</b>



**H Mold Repair Kit**

Can be carried directly to the mold for instant repair in the press. Helps you quickly put your molds back into production. Includes over one dozen each of selected Gesswein Finishing Stones; Stoning and Lubricating Oil; ME Brushes; Blue and Red Mounted Stones and Points; Stone Holders for Gesswein Finishing Stones; Carbide Burs; Gesswein G-Flex and GMX Abrasives; Abrasive SiC Cut-Off Discs; Abrasive Belt Stick; Lapping Sticks, Felt Bobs, Sticks and Hand Buff; three grades of Gesswein Diamond Compounds (each in a one-gram syringe); and Simichrome Polish.

Description	Item#	Each
Basic Kit	<b>382-1000</b>	<b>\$154.35</b>
<b>H.</b> Basic Kit with Dremel #395 Rotary Hand Grinder	<b>382-1010</b>	<b>232.05</b>



**A Gesswein® 54-Piece Finishing Stone Set**

You never know when you will need that special stone for an unexpected job. Keep this set handy to avoid such an occurrence. Includes a total of 54 stones, all of which measure 1/2" x 1/8" x 6" except style 803, which is 4" long. Comes complete with LT Stone Holder #403-1020 and a free sample of Gesswein Stoning and Lubricating Oil.



**Included Stones:**

- 90 grit RA 4093
- 100 grit Premium White 5103W, Moldmaker Plus 1103P
- 120 grit RA 4123, EDM Blue 6123B, EDM 6123, Oil-Treated 5103, Ultra-Soft 7103
- 150 grit Premium White 5153W, Diemaker 2103, Moldmaker Plus 1153P
- 180 grit RA 4183, EDM Blue 6183B, EDM 6183
- 220 grit RA 4203, EDM Blue 6203B, EDM 6203, Premium White 5203W, Oil-Treated 5203, Diemaker 2203, Moldmaker Plus 1203P, Moldmaker 1203
- 320 grit RA 4303, EDM Blue 6303B, EDM 6303, Premium White 5303W, Oil-Treated 5303, Diemaker 2303, Moldmaker Plus 1303P, Moldmaker 1303, Ultra-Soft 7303
- 400 grit RA 4403, EDM Blue 6403B, EDM 6403, Premium White 5403W, Oil-Treated 5403, Diemaker 2403, Moldmaker Plus 1403P, Moldmaker 1403
- 600 grit RA 4603, EDM Blue 6403B, EDM 6603, Premium White 5603W, Oil-Treated 5603, Diemaker 2603, Moldmaker Plus 1603P, Moldmaker 1603, Ultra-Soft 7603
- 800 grit Moldmaker Plus 1803P, White Polishing 803
- 900 grit Diemaker 2903
- 1200 grit Moldmaker Plus 2003P, Super Fine 9003, Ultra-Soft 7003

180	GESSWEIN USA - EDM 6184	180
220	GESSWEIN USA - EDM 6204	220
320	GESSWEIN USA - EDM 6304	320
400	GESSWEIN USA - EDM 6404	400
150	GESSWEIN USA - DP 6154G	150
220	GESSWEIN USA - DP 6254G	220
320	GESSWEIN USA - DP 6324G	320
400	GESSWEIN USA - DP 6404G	400
120	GESSWEIN USA OT 6104	120
220	GESSWEIN USA OT 6204	220
320	GESSWEIN USA OT 6304	320
400	GESSWEIN USA OT 6404	400
220	GESSWEIN USA 1104P	220
150	GESSWEIN USA 1154P	150
150	GESSWEIN USA 2104	150
220	GESSWEIN USA 2204	220
320	GESSWEIN USA - 2304	320
400	GESSWEIN USA - 2404	400
320	GESSWEIN USA 1304P	320
400	GESSWEIN USA 1404P	400

Description	Item#	Each
54-Piece Finishing Stone Set	<b>405-2052</b>	<b>\$84.90</b>

**B Gesswein® 20-Piece Polishing Stone Sets**

Four 20-piece stone sets offered in our most popular stone sizes. Each includes one size of five different types of stones in four different grits. All stones measure 6" long.

Components:	120 grit	150 grit	180 grit	220 grit	320 grit	400 grit
EDM			✓	✓	✓	✓
GP		✓		✓	✓	✓
Oil-Treated	✓			✓	✓	✓
Diemaker	✓			✓	✓	✓
Moldmaker Plus		✓		✓	✓	✓

Description	Size	Item#	Each
20-Piece Polishing Stone Set	1/4" x 1/8"	<b>405-2035</b>	<b>\$37.50</b>
	1/4" x 1/4"	<b>405-2045</b>	<b>39.00</b>
	1/2" x 1/8"	<b>405-2055</b>	<b>42.50</b>
	1/2" x 1/4"	<b>405-2075</b>	<b>53.25</b>

800	GESSWEIN USA - 801	800
800	GESSWEIN USA - 802	800
800	GESSWEIN USA - 803	800
800	GESSWEIN USA - 804	800
800	GESSWEIN USA 1801P	800
800	GESSWEIN USA 1802P	800
800	GESSWEIN USA 1803P	800
800	GESSWEIN USA 1804P	800
900	GESSWEIN USA - 2901	900
900	GESSWEIN USA - 2902	900
900	GESSWEIN USA - 2903	900
900	GESSWEIN USA - 2904	900
800	GESSWEIN USA 7602	800
800	GESSWEIN USA 7603	800
800	GESSWEIN USA 7604	800
1200	GESSWEIN USA 9001	1200
1200	GESSWEIN USA 9002	1200
1200	GESSWEIN USA 9003	1200
1200	GESSWEIN USA 9004	1200

**C Gesswein® 20-Piece Soft & Fine Polishing Stone Set**

Includes five different types of stones in various sizes ideal for final finishing and for preparation prior to diamond polishing. Use Diemaker (900 grit), White Polishing (800 grit) and Super Fine (1200 grit) for polishing steel surfaces, Moldmaker Plus (800 grit) for radius-polishing stainless steel surfaces and Ultra-Soft (600 grit) for polishing aluminum and other soft metal surfaces. All stones measure 6" long except White Polishing and 5/32" x 5/32" Super Fine, which measure 4" long.

Components:	5/32" x 5/32"	1/4" x 1/8"	1/4" x 1/4"	1/2" x 1/8"	1/2" x 1/4"
Diemaker		✓	✓	✓	✓
Moldmaker Plus		✓	✓	✓	✓
White Polishing		✓	✓	✓	✓
Super Fine	✓	✓	✓	✓	✓
Ultra-Soft			✓	✓	✓

Description	Item#	Each
20-Piece Soft & Fine Polishing Stone Set	<b>405-2085</b>	<b>\$55.25</b>



### Gesswein® Introductory Finishing Stone Sets

Choose from eight 12-piece sets of our most popular finishing stones: EDM Blue, EDM, GP, Premium White, Oil-Treated, Diemaker, Moldmaker Plus and Moldmaker Stone Sets. Or purchase our Discovery Stone Set IV, which includes all the 12-piece sets detailed below. Each one serves as an excellent introduction to our finishing stones.

#### Gesswein® 12-Piece EDM Blue Stone Set

Grit	1/4" x 1/8" x 6" Style	1/2" x 1/8" x 6" Style	1/2" x 1/4" x 6" Style
120	6121B	6123B	6124B
180	6181B	6183B	6184B
320	6301B	6303B	6304B
400	6401B	6403B	6404B
Description	Item#		Each
12-Piece EDM Blue Stone Set	<b>405-2040</b>		<b>\$31.75</b>

#### Gesswein® 12-Piece Oil-Treated Stone Set

Grit	1/4" x 1/8" x 6" Style	1/2" x 1/8" x 6" Style	1/2" x 1/4" x 6" Style
220	5201	5203	5204
320	5301	5303	5304
400	5401	5403	5404
600	5601	5603	5604
Description	Item#		Each
12-Piece Oil-Treated Stone Set	<b>405-2090</b>		<b>\$37.00</b>

#### Gesswein® 12-Piece EDM Stone Set

Grit	1/4" x 1/8" x 6" Style	1/2" x 1/8" x 6" Style	1/2" x 1/4" x 6" Style
120	6121	6123	6124
180	6181	6183	6184
320	6301	6303	6304
400	6401	6403	6404
Description	Item#		Each
12-Piece EDM Stone Set	<b>405-2030</b>		<b>\$31.75</b>

#### Gesswein® 12-Piece Diemaker Stone Set

Grit	1/4" x 1/8" x 6" Style	1/2" x 1/8" x 6" Style	1/2" x 1/4" x 6" Style
220	2201	2203	2204
320	2301	2303	2304
400	2401	2403	2404
600	2601	2603	2604
Description	Item#		Each
12-Piece Diemaker Stone Set	<b>405-2060</b>		<b>\$33.85</b>

#### Gesswein® 12-Piece GP Stone Set

Grit	1/4" x 1/8" x 6" Style	1/2" x 1/8" x 6" Style	1/2" x 1/4" x 6" Style
220	6201G	6203G	6204G
320	6301G	6303G	6304G
400	6401G	6403G	6404G
600	6601G	6603G	6604G
Description	Item#		Each
12-Piece GP Stone Set	<b>405-2095</b>		<b>\$29.75</b>

#### Gesswein® 12-Piece Moldmaker Plus Stone Set

Grit	1/4" x 1/8" x 6" Style	1/2" x 1/8" x 6" Style	1/2" x 1/4" x 6" Style
220	1201P	1203P	1204P
400	1401P	1403P	1404P
800	1801P	1803P	1804P
1200	2001P	2003P	2004P
Description	Item#		Each
12-Piece Moldmaker Plus Stone Set	<b>405-2020</b>		<b>\$46.30</b>

#### Gesswein® 12-Piece Premium White Stone Set

Grit	1/4" x 1/8" x 6" Style	1/2" x 1/8" x 6" Style	1/2" x 1/4" x 6" Style
220	5201W	5203W	5204W
320	5301W	5303W	5304W
400	5401W	5403W	5404W
600	5601W	5603W	5604W
Description	Item#		Each
12-Piece Premium White Stone Set	<b>405-2010</b>		<b>\$37.00</b>

#### Gesswein® 12-Piece Moldmaker Stone Set

Grit	1/4" x 1/8" x 6" Style	1/2" x 1/8" x 6" Style	1/2" x 1/4" x 6" Style
220	1201	1203	1204
320	1301	1303	1304
400	1401	1403	1404
600	1601	1603	1604
Description	Item#		Each
12-Piece Moldmaker Stone Set	<b>405-2065</b>		<b>\$35.30</b>

#### Gesswein® 96-Piece Discovery Stone Set IV

Includes all 12-piece sets detailed above—a total of 96 stones. By purchasing all these sets at once, you save over the combined price of buying all the sets individually. Comes complete with a free sample of Gesswein Stoning and Lubricating Oil.

Description	Item#	Each
Discovery Stone Set IV	<b>405-2027</b>	<b>\$187.00</b>





**A**

### **A** LT Stone Holder

An economically priced, lightweight, double-ended stone holder made of durable plastic with a black nonglare finish. One end holds 1/8" x 1/4" stones, and the other holds 1/8" x 1/2" and 1/4" x 1/4" stones. Measures 5 1/2" long.

Description	Item#	Each
LT Stone Holder	<b>403-1020</b>	<b>\$4.35</b>



**B**

### **B** Stone Holder

Screw-type lock holds the stone securely. Designed for comfortable use. Measures 5 7/8" long. Holds 1/2" x 1/4" stones.

Description	Item#	EACH Prices		
		1-2	3-11	12+
Stone Holder	<b>403-0200</b>	<b>\$8.20</b>	<b>\$6.97</b>	<b>\$6.56</b>



**C**

### **C** Handheld Stone Holders

Lightweight aluminum holders designed to hold stones firmly for roughing applications. Measures 7 1/2" long.

For Stone Sizes	Item#	Each
1/4" x 1/2"	<b>403-0355</b>	<b>\$50.65</b>
1/2" x 1/2"	<b>403-0350</b>	<b>50.65</b>
1/2" x 1"	<b>403-0360</b>	<b>55.60</b>



**D**

### **D** Pencil Stone Holder

Push-button holder for easy loading. Holds 5/32" square stones. Measures 5 1/4" long.

Description	Item#	EACH Prices		
		1-2	3-11	12+
<b>D.</b> Pencil Stone Holder	<b>403-0050</b>	<b>\$5.45</b>	<b>\$5.12</b>	<b>\$4.63</b>
Replacement Collet	403-0085	3.25	-	-



**E**

### **E** Double Enders

Will accommodate pencil stones as well as small round and square stones up to 1/4" x 1/4". Available in three colors (blue, black and red) that may be used to distinguish one grit or grade of stone from another. Set of three contains one of each color. Measure 5 7/8" long.

Color	Item#	EACH Prices	
		1-2	3+
Black	<b>403-0102</b>	<b>\$5.20</b>	<b>\$4.68</b>
Blue	<b>403-0101</b>	<b>5.20</b>	<b>4.68</b>
Red	<b>403-0103</b>	<b>5.20</b>	<b>4.68</b>

Description	Item#	EACH Prices	
		1-3	4+
<b>E.</b> Set of all three	<b>403-0120</b>	<b>\$14.00</b>	<b>\$13.30</b>



**F**



**G**



**H**



**I**



**J**



**K**

### **F - K** Super Ceramic Stone Holders – For hand work

For hand work with Super Ceramic Stones. Available in separate 1, 2, 4, 6 and 10mm flat and 3mm round sizes or in a money-saving set of three largest flat sizes. Made of durable plastic. Measure 5 3/4" long.

Description	Item#	Each
<b>F.</b> Flat Holder, 1mm	<b>351-0291</b>	<b>\$4.95</b>
<b>G.</b> Flat Holder, 2mm	<b>351-0292</b>	<b>4.95</b>
<b>H.</b> Flat Holder, 4mm	<b>351-0270</b>	<b>4.95</b>
<b>I.</b> Flat Holder, 6mm	<b>351-0271</b>	<b>4.95</b>
<b>J.</b> Flat Holder, 10mm	<b>351-0272</b>	<b>4.95</b>
<b>K.</b> Round Holder, 3mm	<b>403-0011</b>	<b>8.00</b>
Flat Holders, set of three (4, 6 and 10mm)	<b>351-0273</b>	<b>13.25</b>

**A, B Stone Holders for Reciprocating Handpieces**

Compact, lightweight aluminum holders for use with reciprocating handpieces. Designed to hold stones firmly for polishing applications.

For Stone Sizes	Shank	Item#	Each
1/8" x 1/2", 1/4" x 1/2"	1/8"	<b>403-0301</b>	<b>\$39.40</b>
1/8" x 1/2", 1/4" x 1/2"	3/16"	<b>403-0302</b>	<b>39.40</b>
<b>A.</b> 1/8" x 1/2", 1/4" x 1/2"	1/4"	<b>403-0303</b>	<b>39.40</b>
1/8" x 1/4", 1/4" square	1/8"	<b>403-0304</b>	<b>39.40</b>
1/8" x 1/4", 1/4" square	3/16"	<b>403-0305</b>	<b>39.40</b>
<b>B.</b> 5/32" square	1/8"	<b>403-0306</b>	<b>39.40</b>
1/2" x 1"	1/4"	<b>403-0307</b>	<b>44.05</b>



**A**



**B**

**C Adjustable Stone Holder – 3mm Shank**

Our finest quality. Made of nonmagnetic stainless steel with a 3mm shank. The surface has been tumble-polished to create a nonreflecting satin finish. Accommodates stones up to 1/4" in thickness.

Description	Item#	Each
Adjustable Stone Holder	<b>403-1000</b>	<b>\$66.15</b>



**C**

**D Economy Adjustable Stone Holder – 3mm Shank**

The Economy Adjustable Stone Holder accommodates stones up to 1/16" thick. Plastic serrated jaw holds stones securely. Surface is black and nonreflecting. Made of steel (except serrated jaw and shank housing) with a 3mm shank.

Description	Item#	Each
Economy Adjustable Stone Holder	<b>403-1015</b>	<b>\$35.00</b>



**D**

**E ST-38 Stone Holder – 3mm Shank**

Allows you to secure square, round, and rectangular stones in reciprocating handpieces, including our Power Hand 2X reciprocating handpieces, Di-Profilers and Super Hand Air Filers. Adjustable hinge lets you change the angle of the stone to fit your application. Made of durable plastic with serrated jaws and set screw for tightening stone into place. Accepts round stones up to 1/2" in diameter, rectangular stones up to 3/8"H x 1/2"W and square stones up to 3/8". 3mm steel shank. Complete with allen wrench.

Description	Item#	Each
ST-38 Stone Holder	<b>403-1010</b>	<b>\$20.95</b>



**E**

**F LT Recipro Stone Holder – 1/8" Shank**

Economically priced holder for reciprocating handpieces. Made of durable plastic with black nonglare finish. Shank measures 1/8" dia. x 1/2"L (too short for use with FMH Di-Profiler; acceptable for use with FMC Di-Profiler).

Description	Item#	EACH Prices	
		1-2	3+
Small, for 1/8" x 1/4" stones	<b>403-1025</b>	<b>\$5.85</b>	<b>\$5.27</b>
Large, for 1/8" x 1/2", 1/4" x 1/4" stones and 1/4" Rd.	<b>403-1030</b>	<b>5.85</b>	<b>5.27</b>



**F**

**G Mini-Filer Stone Holder – 3mm Shank**

Expand the use of your mini-filer or our other profilers. Accommodates both flat and round stones or tools up to 1/8". Made of nonmagnetic stainless steel with a 3mm shank. The surface has been tumble-polished to create a nonreflecting satin finish. Use for finer, more precise profiling jobs.

Description	Item#	Each
Mini-Filer Stone Holder	<b>403-1040</b>	<b>\$38.00</b>

See pp. 96 and 109 for mini-filers.



**G**



## A Super Ceramic Stones Strong yet incredibly flexible!

Made of long ceramic fibers that will not break or dull, even when used under the most strenuous conditions or dressed to a very fine point. Put an end to constant stone replacement: 100% of each stone is available for use due to solid ceramic construction. Can be used with fantastic results in our ULTRAMAX ultrasonic handpieces, in Power Hand 2X reciprocating and rotary handpieces or by hand, making them very versatile. Impart uniform surface finishes on molds, dies and precision components. Produce excellent finishing results on stainless steel, copper, aluminum, alloys, silicon, magnetic materials and plastics. Color-coded for easy grit identification. Dress with Super Dresser (see p. 23).

FLAT	Emerald (120 grit) Item#	Gold (180 grit) Item#	Lt. Brown (300 grit) Item#	Orange (400 grit) Item#	Brown (600 grit) Item#	Blue (800 grit) Item#	White (1000 grit) Item#	Red (1200 grit) Item#	Each	
0.5 x 1 x 100	<b>351-0325</b>	<b>351-0326</b>	<b>351-0327</b>	<b>351-0328</b>	<b>351-0329</b>	<b>351-0330</b>	<b>351-0331</b>	<b>351-0332</b>	<b>\$9.95</b>	
0.5 x 4 x 100	<b>351-0301</b>	<b>351-0209</b>	<b>351-0204</b>	<b>351-0206</b>	<b>351-0201</b>	<b>351-0226</b>	<b>351-0227</b>	<b>351-0228</b>	<b>20.90</b>	
0.5 x 6 x 100	<b>351-0302</b>	<b>351-0003</b>	<b>351-0207</b>	<b>351-0208</b>	<b>351-0202</b>	<b>351-0229</b>	<b>351-0230</b>	<b>351-0231</b>	<b>31.45</b>	
0.5 x 10 x 100	<b>351-0303</b>	<b>351-0216</b>	<b>351-0221</b>	<b>351-0222</b>	<b>351-0203</b>	<b>351-0232</b>	<b>351-0233</b>	<b>351-0234</b>	<b>41.25</b>	
0.8 x 4 x 100	<b>351-0304</b>	<b>351-0219</b>	<b>351-0235</b>	<b>351-0236</b>	<b>351-0004</b>	<b>351-0005</b>	<b>351-0010</b>	<b>351-0015</b>	<b>20.90</b>	
0.8 x 6 x 100	<b>351-0305</b>	<b>351-0018</b>	<b>351-0237</b>	<b>351-0238</b>	<b>351-0019</b>	<b>351-0020</b>	<b>351-0025</b>	<b>351-0030</b>	<b>31.45</b>	
0.8 x 10 x 100	<b>351-0306</b>	<b>351-0223</b>	<b>351-0239</b>	<b>351-0240</b>	<b>351-0031</b>	<b>351-0032</b>	<b>351-0033</b>	<b>351-0034</b>	<b>41.25</b>	
1 x 1 x 100	<b>351-0333</b>	<b>351-0334</b>	<b>351-0335</b>	<b>351-0336</b>	<b>351-0337</b>	<b>351-0338</b>	<b>351-0339</b>	<b>351-0340</b>	<b>9.95</b>	
1 x 2 x 100	<b>351-0307</b>	<b>351-0274</b>	<b>351-0275</b>	<b>351-0276</b>	<b>351-0277</b>	<b>351-0278</b>	<b>351-0279</b>	<b>351-0280</b>	<b>12.00</b>	
1 x 4 x 100	<b>351-0308</b>	<b>351-0224</b>	<b>351-0241</b>	<b>351-0242</b>	<b>351-0036</b>	<b>351-0035</b>	<b>351-0040</b>	<b>351-0045</b>	<b>20.90</b>	
1 x 6 x 100	<b>351-0309</b>	<b>351-0048</b>	<b>351-0243</b>	<b>351-0244</b>	<b>351-0049</b>	<b>351-0050</b>	<b>351-0055</b>	<b>351-0060</b>	<b>31.45</b>	
1 x 10 x 100	<b>351-0310</b>	<b>351-0266</b>	<b>351-0245</b>	<b>351-0246</b>	<b>351-0079</b>	<b>351-0080</b>	<b>351-0085</b>	<b>351-0090</b>	<b>41.25</b>	
1.5 x 2.5 x 100	<b>351-0097</b>	<b>351-0098</b>	<b>351-0247</b>	<b>351-0248</b>	<b>351-0091</b>	<b>351-0092</b>	<b>351-0093</b>	<b>351-0094</b>	<b>20.90</b>	
1.5 x 4 x 100	<b>351-0311</b>	<b>351-0267</b>	<b>351-0249</b>	<b>351-0250</b>	<b>351-0109</b>	<b>351-0110</b>	<b>351-0115</b>	<b>351-0120</b>	<b>31.13</b>	
1.5 x 6 x 100	<b>351-0312</b>	<b>351-0268</b>	<b>351-0251</b>	<b>351-0252</b>	<b>351-0124</b>	<b>351-0125</b>	<b>351-0130</b>	<b>351-0135</b>	<b>47.30</b>	
1.5 x 10 x 100	<b>351-0313</b>	<b>351-0269</b>	<b>351-0253</b>	<b>351-0254</b>	<b>351-0136</b>	<b>351-0137</b>	<b>351-0138</b>	<b>351-0139</b>	<b>62.45</b>	
2 x 4 x 100	<b>351-0314</b>	<b>351-0161</b>	<b>351-0255</b>	<b>351-0256</b>	<b>351-0154</b>	<b>351-0155</b>	<b>351-0160</b>	<b>351-0165</b>	<b>41.25</b>	
2 x 6 x 100	<b>351-0315</b>	<b>351-0162</b>	<b>351-0257</b>	<b>351-0258</b>	<b>351-0169</b>	<b>351-0170</b>	<b>351-0175</b>	<b>351-0180</b>	<b>62.90</b>	
2 x 10 x 100	<b>351-0316</b>	<b>351-0163</b>	<b>351-0259</b>	<b>351-0260</b>	<b>351-0181</b>	<b>351-0182</b>	<b>351-0183</b>	<b>351-0184</b>	<b>82.53</b>	
ROUND		Gold (180 grit) Item#	Lt. Brown (300 grit) Item#	Orange (400 grit) Item#	Brown (600 grit) Item#	Blue (800 grit) Item#	White (1000 grit) Item#	Red (1200 grit) Item#	Each	
3 x 50mm		<b>351-0317</b>	<b>351-0157</b>	<b>351-0196</b>	<b>351-0197</b>	<b>351-0198</b>	<b>351-0200</b>	<b>351-0205</b>	<b>351-0210</b>	<b>\$20.45</b>
3/32" x 2"		<b>351-0318</b>	<b>351-0156</b>	<b>351-0261</b>	<b>351-0262</b>	<b>351-0263</b>	<b>351-0264</b>	<b>351-0265</b>	<b>351-0159</b>	<b>18.54</b>
1/8" x 2"		<b>351-0319</b>	<b>351-0158</b>	<b>351-0217</b>	<b>351-0218</b>	<b>351-0211</b>	<b>351-0212</b>	<b>351-0213</b>	<b>351-0214</b>	<b>25.65</b>



## B Super Ceramic Stone Flat Polishing Set

This 12-piece set includes five flat 1 x 4 x 100mm Emerald, Gold, Lt. Brown, Blue and Red stones (120, 180, 300, 800 and 1200 grit, respectively), five flat 1 x 6 x 100mm Lt. Brown, Orange, Brown, Blue and White stones (300, 400, 600, 800 and 1000 grit, respectively), 4mm flat holder and 6mm flat holder.

Description	Item#	Each
Flat Polishing Set	<b>351-0320</b>	<b>\$162.99</b>



## C Super Ceramic Stone Round Polishing Set

This six-piece set includes five round 3 x 50mm Gold, Lt. Brown, Brown, Blue and Red stones (180, 300, 600, 800 and 1200 grit, respectively) and 3mm round holder.

Description	Item#	Each
Round Polishing Set	<b>351-0322</b>	<b>\$66.15</b>



**A Super Ceramic Diamond Stones**

**An effective combination of ceramic fibers and diamond particles.**

SCD Stones combine ceramic fibers with multiple layers of evenly distributed diamond particles to provide continuous cutting action for finishing hardened steel and carbide tools. SCD Stones won't load like plated diamond files, are more efficient than diamond compounds and are easily shaped. Unlike ceramic stones, which polish only on an angle at their tips, SCD Stones cut and polish flat to a surface, allowing fast and accurate polishing in open areas. Perfect for polishing ribs, hard-to-reach slots and sidewalls and milled or EDM flat surfaces. Their strong, durable ceramic fiber construction makes them ideal for use in ultrasonic polishers. Also effective when used in mechanical profilers and by hand. Available in flat and round shapes in three color-coded grits.

Shape	Size (mm)	Black	Gray	Green	EACH Prices	
		(200 grit) Item#	(400 grit) Item#	(600 grit) Item#	1-4	5+*
Flat	1 x 2 x 100	<b>351-0797</b>	<b>351-0798</b>	<b>351-0799</b>	<b>\$14.50</b>	<b>\$13.05</b>
	1 x 4 x 100	<b>351-0800</b>	<b>351-0801</b>	<b>351-0802</b>	<b>28.50</b>	<b>25.65</b>
	1 x 6 x 100	<b>351-0803</b>	<b>351-0804</b>	<b>351-0805</b>	<b>43.30</b>	<b>38.97</b>
	1 x 10 x 100	<b>351-0806</b>	<b>351-0807</b>	<b>351-0808</b>	<b>56.90</b>	<b>51.21</b>
Round	3 x 50	<b>351-0809</b>	<b>351-0810</b>	<b>351-0811</b>	<b>39.30</b>	<b>35.37</b>
	3 x 100	<b>351-0812</b>	<b>351-0813</b>	<b>351-0814</b>	<b>78.60</b>	<b>70.74</b>

\*Quantity discount for orders of one item# only, not assorted.

**B Super Dresser**

Used to dress Super Ceramic Stones and Diamond or CBN Wheels. Measures 1/8" x 1" x 1/4" (3 x 25 x 100mm).

Description	Item#	Each
Super Dresser	<b>351-0300</b>	<b>\$13.45</b>

**C - H Super Ceramic Stone Holders – For hand work**

For hand work with Super Ceramic Stones. Available in separate 1, 2, 4, 6 and 10mm flat and 3mm round sizes or in a money-saving set of three largest flat sizes. Made of durable plastic. Measure 5 3/4" long.

Description	Item#	Each
<b>C.</b> Flat Holder, 1mm	<b>351-0291</b>	<b>\$4.95</b>
<b>D.</b> Flat Holder, 2mm	<b>351-0292</b>	<b>4.95</b>
<b>E.</b> Flat Holder, 4mm	<b>351-0270</b>	<b>4.95</b>
<b>F.</b> Flat Holder, 6mm	<b>351-0271</b>	<b>4.95</b>
<b>G.</b> Flat Holder, 10mm	<b>351-0272</b>	<b>4.95</b>
<b>H.</b> Round Holder, 3mm	<b>403-0011</b>	<b>8.00</b>
Flat Holders, set of three (4, 6 and 10mm)	<b>351-0273</b>	<b>13.25</b>

**I Super Mounted Ceramic Stones – 3mm Shank**

Cylinder-shaped Super Ceramic Stones. All come mounted on 3mm shanks.

Size (mm)	Color	Grit	Max. RPM	Item#	EACH Prices	
					1-4	5+
6 x 10	Gold	180	88,000	<b>351-0283</b>	<b>\$28.50</b>	<b>\$25.65</b>
8 x 10	Gold	180	76,000	<b>351-0284</b>	<b>41.10</b>	<b>36.99</b>
10 x 10	Gold	180	66,400	<b>351-0285</b>	<b>53.20</b>	<b>47.88</b>

**J - M Super Ceramic Wheels**

Wheel-shaped Super Ceramic Stones. Use for polishing or as a superior grade cut-off wheel. Available in four grits. See p. 131 for mandrel selection.

Size (mm)	Color	Grit	Max. RPM	Item#	EACH Prices	
					1-4	5+
<b>J.</b> 22 x 1.8 x 6	Lt. Brown	300	27,000	<b>351-0287</b>	<b>\$24.95</b>	<b>\$22.46</b>
<b>K.</b> 22 x 1.8 x 6	Orange	400	27,000	<b>351-0288</b>	<b>24.95</b>	<b>22.46</b>
<b>L.</b> 22 x 1.8 x 6	Brown	600	27,000	<b>351-0289</b>	<b>24.95</b>	<b>22.46</b>
<b>M.</b> 22 x 1.8 x 6	Blue	800	27,000	<b>351-0290</b>	<b>24.95</b>	<b>22.46</b>

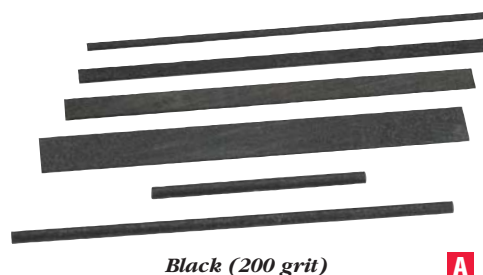

Black (200 grit)

**A**

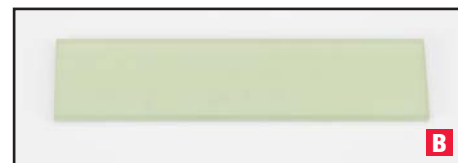

**B**

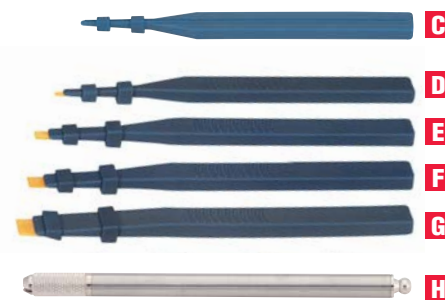

**C**

**D**

**E**

**F**

**G**

**H**



**I**

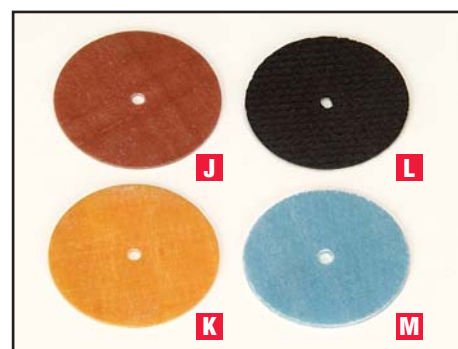

**J**

**L**

**K**

**M**

## Gesswein® Ruby® Stones and Files – For use on hardened steel and carbide.

Gesswein Ruby Stones and Files are made from pure, sintered crystals of synthetic ruby. No bonding material is used, so these stones and files are extremely hard and resistant to changes in shape. This is particularly important for quality precision grinding and finishing.

In addition, since Gesswein Ruby Stones and Files feature outstanding resistance to wear, they are more economical to use than other comparable tools. Use dry or with Gesswein Stoning Oil to grind, touch up or debur steel and carbide parts. Also recommended for use on materials such as glass, quartz and porcelain.

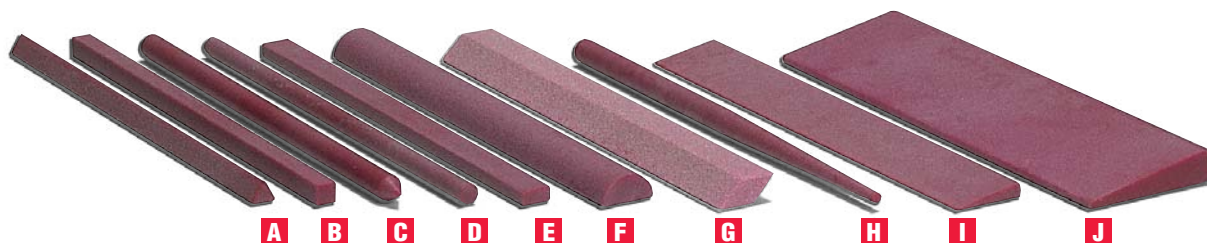

### A - J Ruby® Stones

For general-purpose work. Available in coarse, medium and fine grits.

Shape	L x W x H* (mm)	Coarse		Medium		Fine	
		Item#	Each	Item#	Each	Item#	Each
A. Triangular ▲	100 x 4	-	-	350-2002	\$44.95	-	-
	100 x 6	350-2011	\$49.95	350-2012	49.95	-	-
	100 x 8	350-2021	64.75	350-2022	70.95	350-2023	\$80.50
	100 x 10	-	-	350-2032	71.25	350-2033	95.25
B. Square ■	100 x 4	-	-	350-2102	52.75	-	-
	100 x 6	350-2111	49.65	350-2112	54.75	-	-
	100 x 8	350-2121	60.75	350-2122	70.45	350-2123	70.65
	100 x 10	350-2131	70.65	350-2132	78.95	350-2133	80.60
	120 x 13	-	-	350-2142	92.60	350-2143	102.85
C. Round, Pointed ●	100 x 5	-	-	-	-	350-2613	51.25
D. Round ●	100 x 4	-	-	350-2702	51.25	350-2703	55.75
	100 x 6	350-2711	55.95	350-2712	55.95	-	-
	100 x 8	350-2721	67.00	350-2722	49.85	350-2723	69.25
	100 x 10	350-2731	67.50	350-2732	72.85	350-2733	76.85
E. Flat ▬	100 x 6 x 3	-	-	350-2202	42.95	350-2203	42.30
	100 x 8 x 6	350-2211	54.75	350-2212	54.75	350-2213	64.50
F. Half-Round ⤴	100 x 10	350-2311	57.00	350-2312	68.75	-	-
G. Rhomboid ▱	100 x 13 x 5	350-2401	73.85	-	-	-	-
H. Round, One Tapered End ●	100 x 5 x 2	350-2551	49.70	-	-	350-2553	49.70
I. Knife Edge ◄	100 x 15 x 3/0.5	-	-	350-2912	105.75	350-2913	105.75
J. Tapered, Rounded Edge ◄	100 x 30 x 7/2	-	-	350-1052	141.00	-	-

\*All dimensions have tolerance of ±0.1mm.

### K Ruby® Stone Set #700

This handy set contains one each of the Ruby Stones indicated. Save over \$50.00 off the combined price of buying the stones individually.

Shape		L x W x H* (mm)	Grit
Round	●	100 x 6	Medium
Triangular	▲	100 x 10	Medium
Flat	▬	100 x 8 x 6	Fine
Half-Round	⤴	100 x 10	Coarse
Square	■	100 x 10	Medium
Description		Item#	Each
K. Ruby Stone Set #700		350-3000	\$235.75

\*All dimensions have tolerance of ±0.1mm.



**A - K Ruby® Midget Files**

Ruby Midget Files are invaluable for high detail and ultra-precision work. They may be broken off and cemented onto a holder or used with a pin vise (see p. 242). Available in fine grit.

Shape	L x W x H* (mm)	Item#	EACH Prices	
			1-19	20+
<b>A.</b> Square ■	50 x 1	<b>350-4000</b>	<b>\$5.85</b>	<b>\$4.87</b>
<b>B.</b> Round ●	50 x 1	<b>350-4010</b>	<b>6.35</b>	<b>5.29</b>
<b>C.</b> Triangular ▲	50 x 2	<b>350-4020</b>	<b>7.65</b>	<b>6.37</b>
<b>D.</b> Flat —	50 x 3 x 0.3	<b>350-4060</b>	<b>7.65</b>	<b>6.37</b>
Shape	L x W x H* (mm)	Item#	EACH Prices	
			1-9	10+
<b>E.</b> Square ■	100 x 2	<b>350-4030</b>	<b>\$14.85</b>	<b>\$12.37</b>
<b>F.</b> Round ●	100 x 2	<b>350-4040</b>	<b>14.85</b>	<b>12.37</b>
<b>G.</b> Round ●	100 x 3	<b>350-4050</b>	<b>14.85</b>	<b>12.37</b>
<b>H.</b> Half-Round ◐	100 x 4 x 2	<b>350-4070</b>	<b>23.45</b>	<b>19.54</b>
<b>I.</b> Barrette ◑	100 x 5 x 1.5	<b>350-4090</b>	<b>24.75</b>	<b>20.62</b>
<b>J.</b> Crossing ◒	100 x 4 x 1.5	<b>350-4110</b>	<b>23.45</b>	<b>19.54</b>
<b>K.</b> Triangular ▲	100 x 3	<b>350-4130</b>	<b>23.45</b>	<b>19.54</b>

\*All dimensions have tolerance of ±0.1mm.

**L Ruby® Midget File Set #420**

This money-saving kit contains all 11 of our Ruby Midget Files (see above) plus one double-ended holder with two collets. (Holder is available only with this kit and not separately.) Screw machine operators will find this set particularly helpful for dressing cutters without removing them from the machine.

Description	Item#	Each
Ruby Set #420	<b>350-4200</b>	<b>\$134.50</b>

**M Ruby® Bench Stones**

Ideal for sharpening and for flattening steel and carbide parts. The first two sizes of stones listed are finished on both sides. The rest are finished on one side only and come neatly mounted in wooden boxes.

Dimensions (inches)	Medium		Fine	
	Item#	Each	Item#	Each
4 x 1 x 3/8*	<b>350-1002</b>	<b>\$87.95</b>	<b>350-1003</b>	<b>\$102.00</b>
6 x 1 x 5/8*	<b>350-1012</b>	<b>141.00</b>	<b>350-1013</b>	<b>141.00</b>
4 x 1 x 3/8	<b>350-1102</b>	<b>75.00</b>	<b>350-1103</b>	<b>99.95</b>
4 3/4 x 2 x 3/8	<b>350-1112</b>	<b>75.00</b>	<b>350-1113</b>	<b>99.95</b>

\*Finished on both sides

**N Ruby® Combination Bench Stone**

Finished on two sides and neatly packaged in a wooden box. One side of the stone is medium, and the other is fine. Measures 4 3/4"L x 2"W x 3/8"H.

Description	Item#	Each
Ruby Combination Bench Stone	<b>350-1114</b>	<b>\$247.25</b>

**O Deborit Handlapper**

Made of sintered boron carbide. Especially recommended for tungsten carbide and oxide ceramics. Will also dress ruby stones. Abrasive portion is 1 3/8"L x 1/2"W x 3/16"H. Handle measures 6" overall length.

Grit	Item#	Each
Medium	<b>350-5152</b>	<b>\$109.50</b>
Fine	<b>350-5153</b>	<b>109.50</b>

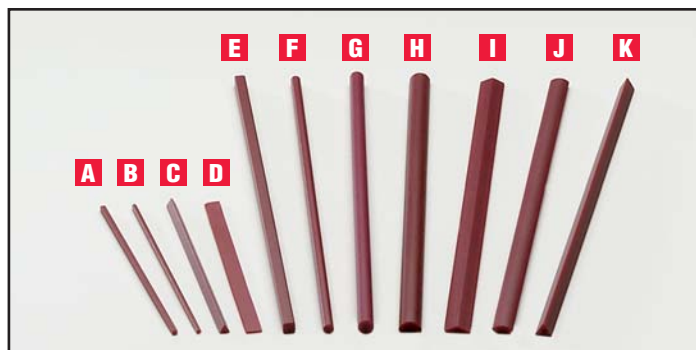

## Norton® Arkansas Stones

Natural Arkansas Stones have gained a reputation over the years as the finest all-purpose stones for deburring and polishing operations as well as for sharpening precision tools. Hard Arkansas Stones are dense and fine-grained for final honing where the sharpest precision edges possible are needed. Soft Arkansas, with its less dense and more open structure, is ideal for imparting a fine, smooth surface. Arkansas Stones are not oil-filled and should be used with Gesswein Stoning Oil (see p. 31).

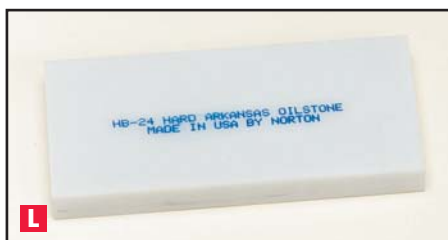
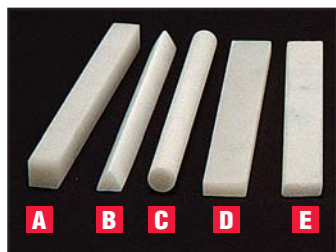

### A - I Norton® Hard Arkansas Files – Ultra-Fine Grit

Dense, translucent stones in various shades of gray. All have precision edges.

Shape	Dimensions	Style	Item#	EACH Prices	
				1-9	10+
A. Square	3" x 1/4"	HF13	<b>370-0130</b>	<b>\$16.10</b>	<b>\$10.79</b>
	3" x 3/8"	HF33	<b>370-0330</b>	<b>17.25</b>	<b>11.56</b>
	3" x 1/2"	HF43	<b>370-0430</b>	<b>22.35</b>	<b>14.97</b>
B. Triangular	3" x 1/4"	HF113	<b>370-1130</b>	<b>16.10</b>	<b>10.79</b>
	3" x 3/8"	HF133	<b>370-1330</b>	<b>17.25</b>	<b>11.56</b>
	3" x 1/2"	HF143	<b>370-1430</b>	<b>22.35</b>	<b>14.97</b>
C. Round	3" x 1/4"	HF813	<b>370-8130</b>	<b>20.35</b>	<b>13.63</b>
D. Flat	3" x 3/8" x 1/8"	HF823	<b>370-8230</b>	<b>25.50</b>	<b>17.09</b>
E. Bevel	3" x 3/8" x 1/8"	HF833	<b>370-8330</b>	<b>16.60</b>	<b>11.12</b>
F. Diamond	3" x 1/2" x 3/16"	HF843	<b>370-8430</b>	<b>31.50</b>	<b>21.11</b>
G. Oval	3" x 1/2" x 3/16"	HF853	<b>370-8530</b>	<b>25.50</b>	<b>17.09</b>
H. Point	3" x 1/4" base	HF863	<b>370-8630</b>	<b>30.05</b>	<b>20.13</b>
I. Knife Blade	3" x 3/4" x 1/8"	HF873	<b>370-8730</b>	<b>27.20</b>	<b>18.22</b>

### J Norton® Soft Arkansas Engraver's Point AT11 – Extra-Fine Grit

Small size for tight areas. Used in Engraver's Chuck XT-1.

Shape	Dimensions	Style	Item#	EACH Prices	
				1-19	20+
Point	1" x 1/8" dia.	AT11	<b>372-5110</b>	<b>\$6.95</b>	<b>\$4.66</b>

### K Engraver's Chuck XT-1

For mounting either India or Arkansas Engraver's Points. Made of knurled, nickel-plated steel. Rounded end fits comfortably in palm of hand. Measures 3 3/8" overall length.

Style	L x Dia.	Item#	EACH Prices	
			1-9	10+
XT-1	3 3/8" x 1/4"	<b>372-6000</b>	<b>\$23.65</b>	<b>\$15.85</b>

### L Norton® Hard Arkansas Bench Stones – Ultra-Fine Grit

Extremely hard and fine unmounted stones for the final finish on gravers and cutting tools. Can be used on both sides.

Dimensions	Style	Item#	EACH Prices	
			1-4	5+
4" x 2" x 3/8"	HB24	<b>371-1045</b>	<b>\$76.60</b>	<b>\$51.32</b>
4" x 2" x 3/4"	HB4	<b>371-1040</b>	<b>115.85</b>	<b>77.62</b>

### M Norton® Arkansas Penknife Stones

Can be used on both sides. Hard are ultra-fine grit, soft is extra-fine grit.

Type	Dimensions	Style	Item#	EACH Prices	
				1-9	10+
Hard	3" x 1" x 3/8"	HB13	<b>371-1130</b>	<b>\$27.95</b>	<b>\$18.73</b>
Hard	4" x 1" x 3/8"	HB14	<b>371-1140</b>	<b>33.40</b>	<b>22.38</b>
Soft	4" x 1" x 3/8"	SB14	<b>371-4140</b>	<b>10.70</b>	<b>7.17</b>



**A Quad-Hone Stone**

Four different stones mounted on a rectangular block for a wide range of sharpening chores from rough shaping to producing a sharp final edge. Quad-Hone includes one each of coarse, medium, fine and ultra-fine Arkansas stones. Each stone measures approximately 6"L x 1"W x 1/4"H. Use with Gesswein Stoning Oil (see p. 31).

Description	Item#	Each
Quad-Hone Stone	<b>380-1102</b>	<b>\$31.75</b>



**A**

**B - E Hard Black Arkansas Files – Fine Grit**

For the machinist, woodworker or gunsmith who requires a smooth polished edge. These dense black stones are more aggressive than other Hard Arkansas Stones. The various shapes and sizes are ideal for deburring and polishing intricate tools and metal parts.

Shape	Dimensions	Item#	EACH Prices	
			1-9	10+
<b>B. Square</b> ■	3" x 1/4"	<b>375-0131</b>	<b>\$10.75</b>	<b>\$9.68</b>
	3" x 3/8"	<b>375-0331</b>	<b>11.75</b>	<b>10.58</b>
	3" x 1/2"	<b>375-0431</b>	<b>13.99</b>	<b>12.59</b>
<b>C. Triangular</b> ▲	3" x 1/4"	<b>375-1131</b>	<b>10.90</b>	<b>9.81</b>
	3" x 3/8"	<b>375-1331</b>	<b>10.85</b>	<b>9.77</b>
	3" x 1/2"	<b>375-1431</b>	<b>14.90</b>	<b>13.41</b>
<b>D. Round</b> ●	3" x 1/4"	<b>375-8131</b>	<b>12.50</b>	<b>11.25</b>
<b>E. Knife Edge</b> ►	3 1/2" x 3/4" x 1/8" (tapers to a knife edge)	<b>375-8731</b>	<b>18.25</b>	<b>16.43</b>



**B**

**C**

**D**

**E**

**F Hard Black Arkansas Bench Stone – Fine Grit**

For precision sharpening or for finishing a very sharp edge. Measures 6"L x 2"W x 1/2"H. Packaged in an attractive cedar box.

Description	Item#	Each
Fine Grit	<b>374-2000</b>	<b>\$53.99</b>



**F**

**G Soft Arkansas Bench Stone – Medium Grit**

A natural medium-grit bench stone. Recommended for relatively fast cutting. Excellent for shaping gravers, knives and precision tools prior to final finish with our Ruby or Hard Arkansas Stones. Use with Stoning Oil (see p. 31). Packaged in an attractive cedar box. Measures 6"L x 2"W x 1"H.

Description	Item#	Each
Medium Grit	<b>374-1000</b>	<b>\$22.60</b>



**G**

**H, I Hard Arkansas Stones – Very Fine Grit**

Genuine Hard Arkansas Stones, white to light gray. Each is glued into a hardwood storage box. Top surface of stone is finished and usable.

Dimensions	Item#	Each
<b>H.</b> 100 x 40mm (4" x 1 5/8")	<b>374-0900</b>	<b>\$37.50</b>
<b>I.</b> 150 x 50mm (6" x 2")	<b>374-0910</b>	<b>92.60</b>



**H**

**I**

## Norton® India® Stones

These sharpening stones are made of synthetic aluminum oxide abrasive graded to a consistent particle size, blended with select bonding agents, molded to shape and finished to exacting surface configurations. Preferred for imparting durable, smooth cutting edges and finishing to close tolerances. Orange-brown in color.

Prefilled with oil to make cutting easier and more effective, retard loading and

eliminate the need for presoaking prior to first use. Note: Although prefilling minimizes the amount of oil needed, it does not eliminate the need for oil on the stone surface. Apply Gesswein Stoning and Lubricating Oil (see p. 31) on the stone's sharpening surface prior to each use. This will prevent the pores of the stone from filling with material removed from the object being stoned.

India Stones are available in coarse, medium and fine grits. Use coarse grit for restoring badly worn cutting edges and for all sharpening not requiring a keen edge; use medium grit for producing an average edge on a broad range of tools, such as carving tools, milling cutters, lathe tools and die chasers; and use fine grit for producing sharper-than-average edges on gouges, reamers, taps and twist drills.



### A India® Abrasive Files

Hold their shape while producing a fine, uniform finish. Use to debur, chamfer, radius and fit delicate parts. Choose from square, triangular, round and half-round to match different surface contours. Triangular files are excellent for reaching tight corners without disturbing other surfaces. Measure 4" long except #76, which measures 6".

Shape	Size Style	(inches)	Grit			EACH Prices	
			Coarse (100 grit) Item#	Medium (240 grit) Item#	Fine (320 grit) Item#	1-19	20+
Square	14	1/4	<b>360-0141</b>	<b>360-0142</b>	<b>360-0143</b>	<b>\$5.14</b>	<b>\$3.44</b>
	34	3/8	<b>360-0341</b>	<b>360-0342</b>	<b>360-0343</b>	<b>6.50</b>	<b>4.36</b>
	44	1/2	<b>360-0441</b>	<b>360-0442</b>	<b>360-0443</b>	<b>6.50</b>	<b>4.36</b>
	76	1	<b>360-0761</b>	<b>360-0762</b>	<b>360-0763</b>	<b>11.72</b>	<b>7.85</b>
Triangular	114	1/4	<b>360-1141</b>	<b>360-1142</b>	<b>360-1143</b>	<b>7.15</b>	<b>4.79</b>
	134	3/8	<b>360-1341</b>	<b>360-1342</b>	<b>360-1343</b>	<b>7.50</b>	<b>5.03</b>
	144	1/2	<b>360-1441</b>	<b>360-1442</b>	<b>360-1443</b>	<b>7.50</b>	<b>5.03</b>
Round	214	1/4	<b>360-2141</b>	<b>360-2142</b>	<b>360-2143</b>	<b>9.79</b>	<b>6.56</b>
	234	3/8	<b>360-2341</b>	<b>360-2342</b>	<b>360-2343</b>	<b>10.50</b>	<b>7.04</b>
	244	1/2	<b>360-2441</b>	<b>360-2442</b>	<b>360-2443</b>	<b>10.70</b>	<b>7.17</b>
Half-Round	314	1/4	—	<b>360-3142</b>	<b>360-3143</b>	<b>8.20</b>	<b>5.49</b>
	324	5/16	—	<b>360-3242</b>	—	<b>8.95</b>	<b>6.00</b>
	334	3/8	—	<b>360-3342</b>	<b>360-3343</b>	<b>8.75</b>	<b>5.86</b>
	344	1/2	<b>360-3441</b>	<b>360-3442</b>	<b>360-3443</b>	<b>8.95</b>	<b>6.00</b>

(Stones are made to an approximate  $\pm 1/8$ " length tolerance.)



### B Medium India® Pencil Stone

Style	Grit	Size	Item#	EACH Prices			
				1-11	12-71	72-143	144+
10	240	4" x 5/32" x 5/32"	<b>415-0100</b>	<b>\$2.40</b>	<b>\$2.00</b>	<b>\$1.80</b>	<b>\$1.61</b>



### C Pencil Stone Holder

Push-button holder for easy loading. Holds 5/32" square stones. Measures 5 1/4" long.

Description	Item#	EACH Prices		
		1-2	3-11	12+
C. Pencil Stone Holder	<b>403-0050</b>	<b>\$5.45</b>	<b>\$5.12</b>	<b>\$4.63</b>
Replacement Collet	403-0085	3.25	—	—



### D India® Engraver's Point

For stoning and cleaning tight corners and recesses of dies where close tolerances and accuracy are important. Measures 1" L x 1/8" dia. and tapers to a point. Fine (320 grit). Use in Engraver's Chuck XT-1 (below).

Style	L x Dia.	Item#	EACH Prices	
			1-49	50+
FT-11	1" x 1/8"	<b>362-5113</b>	<b>\$6.10</b>	<b>\$4.09</b>



### E Engraver's Chuck XT-1

For holding either India or Arkansas Engraver's Points. Made of knurled, nickel-plated steel. Rounded end fits comfortably in palm of hand. Measures 3 3/8" long.

Style	L x Dia.	Item#	EACH Prices	
			1-9	10+
XT-1	3 3/8" x 1/4"	<b>372-6000</b>	<b>\$23.65</b>	<b>\$15.85</b>

**A - H India® Silversmith Stones**

A variety of precision-shaped tapered stones used by silversmiths and mechanics for touching up instruments, lapping for close tolerances and cleaning tools and dies. Use round-edged stones to speed up the sharpening of curved tool steels and carbide tools. Use sharp-angled stones to get into hard-to-reach corners. Available only in aluminum oxide in coarse, medium and fine grits.

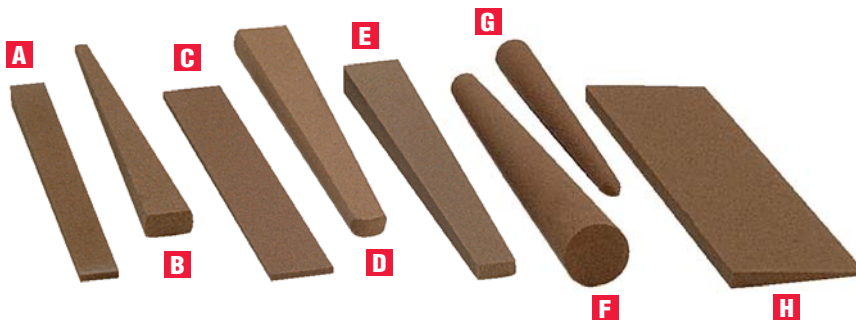

Style	L x W x H (inches)	Tapered to W x H (inches)	Coarse (100 grit)		Medium (240 grit)		Fine (320 grit)		EACH Prices	
			Item#		Item#		Item#		1-19	20+*
<b>A. F-414</b>	4 x 5/16 x 3/16	5/16 x 1/16	—		<b>360-4142</b>		<b>360-4143</b>		<b>\$12.90</b>	<b>\$8.64</b>
<b>B. F-424</b>	4 x 3/8 x 3/16	1/8 x 1/16	—		<b>360-4242</b>		—		<b>12.90</b>	<b>8.64</b>
<b>C. F-444</b>	4 x 1/2 x 1/16	—	<b>360-4441</b>		<b>360-4442</b>		<b>360-4443</b>		<b>12.90</b>	<b>8.64</b>
<b>D. F-464</b>	4 x 1/2 x 1/4	5/16 x 1/8	—		<b>360-4642</b>		—		<b>11.85</b>	<b>7.94</b>
<b>E. F-474</b>	4 x 1/2 x 1/4	5/16 x 1/8	—		<b>360-4742</b>		<b>360-4743</b>		<b>12.90</b>	<b>8.64</b>
<b>F. F-644</b>	4 x 1/2 x 1/4	—	<b>360-6441</b>		<b>360-6442</b>		<b>360-6443</b>		<b>12.90</b>	<b>8.64</b>
<b>G. F-723</b>	3 x 5/16 base	—	<b>360-7231</b>		<b>360-7232</b>		<b>360-7233</b>		<b>15.75</b>	<b>10.55</b>
<b>H. F-724</b>	4 x 1 x 1/8 base	—	<b>360-7241</b>		<b>360-7242</b>		<b>360-7243</b>		<b>11.95</b>	<b>8.01</b>

\*Quantity discount for orders of one item# only, not assorted.

**I - K India® Reamer Stones**

Durable fast-cutting stones designed for imparting a professional edge on reamers, taps and rough rounders on shoe machine tools. Available in aluminum oxide in medium and fine grits.

Style	L x W x H (inches)	Medium Grit Item#	EACH Prices		Fine Grit Item#	EACH Prices	
			1-19	20+		1-19	20+
<b>I. T124</b>	4 1/2 x 1 x 5/16	<b>360-1242</b>	<b>\$9.95</b>	<b>\$6.67</b>	—	—	—
<b>J. T125</b>	5 x 1 x 3/16	<b>360-1252</b>	<b>9.95</b>	<b>6.67</b>	<b>360-1253</b>	<b>\$9.95</b>	<b>\$6.67</b>
<b>K. T126</b>	6 x 1 x 1/4	<b>360-1262</b>	<b>14.25</b>	<b>9.55</b>	—	—	—

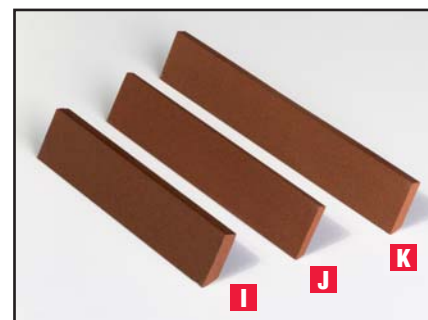

**L India® Bench Stones**

Manufactured with the same aluminum oxide as our other India stones, Bench Stones are most popular for producing a strong, keen, long-lasting edge on high-quality tools. The frequent choice of artisans, craftsmen and mechanics. Use India Bench Stones to quickly restore the cutting edge on all straightedge tools, including chisels, plane blades, wood lathe cutters, draw knives, spoke shaves, precision tools and delicate instruments.

Style	L x W x H (inches)	Coarse (100 grit) Item#	Medium (240 grit) Item#	Fine (320 grit) Item#	EACH Prices	
					1-9	10+*
<b>B-14</b>	4 x 1 x 1/4	<b>361-0141</b>	<b>361-0142</b>	<b>361-0143</b>	<b>\$7.50</b>	<b>\$5.03</b>
<b>B-24</b>	4 x 1 x 1/2	<b>361-0241</b>	<b>361-0242</b>	<b>361-0243</b>	<b>9.35</b>	<b>6.26</b>
<b>B-6</b>	6 x 2 x 1	<b>361-0061</b>	<b>361-0062</b>	<b>361-0063</b>	<b>23.40</b>	<b>15.68</b>
<b>B-8</b>	8 x 2 x 1	<b>361-0081</b>	<b>361-0082</b>	<b>361-0083</b>	<b>27.40</b>	<b>18.36</b>

\*Quantity discount for orders of one item# only, not assorted.

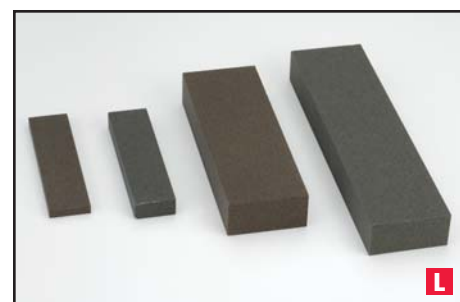

**M India® Combination Bench Stones**

Each Combination India Bench Stone has fine and coarse grit surfaces (one grit to each side), providing complete, economical sharpening.

Style	L x W x H (inches)	Item#	EACH Prices	
			1-9	10+
<b>IB-134</b>	4 x 1 3/4 x 5/8	<b>361-1344</b>	<b>\$15.70</b>	<b>\$10.52</b>
<b>IB-6</b>	6 x 2 x 1	<b>361-0064</b>	<b>23.90</b>	<b>16.01</b>
<b>IB-8</b>	8 x 2 x 1	<b>361-0084</b>	<b>29.60</b>	<b>19.83</b>



## Norton® Crystolon® Stones

Crystolon Stones are made of silicon carbide electric furnace abrasive. Electric furnace stones are made by ball-milling the abrasive to the correct particle size, then batch-blending with carefully selected

bonding agents to produce the precise characteristics desired in the finishing stone. The fast-cutting abrasive is harder than any natural abrasive except diamond and does an outstanding job where moderate tolerances

are desired. The resulting tool edge lacks durability as compared to India. Crystolon is the choice when speed of sharpening is more important than fineness of the cutting edge.

### A Crystolon® Stone Files

A fast-acting silicon carbide stone. Designed for use where moderate tolerances are acceptable. Available in square, triangular and round shapes in medium and fine grit. Measure 4" long.



Shape	Size (inches)	Style	Medium Grit		EACH Prices	
			Item#		1-19	20+
Square	4 x 1/4	MJF-14	<b>376-0001</b>		<b>\$6.75</b>	<b>\$4.52</b>
		MJF-44	<b>376-0005</b>		<b>6.80</b>	<b>4.56</b>
Round	4 x 1/4	MJF-214	<b>376-0064</b>		<b>10.55</b>	<b>7.07</b>
	4 x 3/8	MJF-234	<b>376-0066</b>		<b>9.80</b>	<b>6.57</b>
	4 x 1/2	MJF-244	<b>376-0068</b>		<b>10.85</b>	<b>7.27</b>
Triangular	4 x 1/4	MJF-114	<b>376-0028</b>		<b>8.50</b>	<b>5.70</b>
	4 x 3/8	MJF-134	<b>376-0030</b>		<b>7.95</b>	<b>5.33</b>

Shape	Size (inches)	Style	Fine Grit		EACH Prices	
			Item#		1-19	20+
Square	4 x 1/2	FJF-44	<b>376-0006</b>		<b>\$6.80</b>	<b>\$4.56</b>
Round	4 x 1/4	FJF-214	<b>376-0065</b>		<b>10.55</b>	<b>7.07</b>
Triangular	4 x 1/4	FJF-114	<b>376-0029</b>		<b>8.50</b>	<b>5.70</b>
	4 x 3/8	FJF-134	<b>376-0031</b>		<b>7.63</b>	<b>5.11</b>
	4 x 1/2	FJF-144	<b>376-0033</b>		<b>8.85</b>	<b>5.93</b>

### B Crystolon® Dress Slips

Silicon carbide stones used to maintain carbide tool edges, thereby keeping regrinding costs and time to an absolute minimum. Not oil-filled. Available in coarse, medium and fine grits. Measure 3 1/2" x 3/4" x 1/2".



Grit	Style	Item#	EACH Prices	
			1-19	20+
Coarse	CJT-63	<b>380-1050</b>	<b>\$10.94</b>	<b>\$7.33</b>
Medium	MJT-63	<b>380-1051</b>	<b>12.35</b>	<b>8.27</b>
Fine	FJT-63	<b>380-1052</b>	<b>8.70</b>	<b>5.83</b>

### C Crystolon® Combo Bench Stone

Silicon carbide bench stone has two distinct cutting surfaces: one side is coarse, the other side is fine. Fast-cutting for general sharpening of cutting tools. Dark gray in color. Measures 6"L x 2"W x 1"H.



Description	Style	Item#	Each
Crystolon Combo Bench Stone	JB-6	<b>371-2004</b>	<b>\$24.95</b>



**A Rub-and-Rinse Stone Cleaner**

Gesswein Rub-and-Rinse Stone Cleaner is a semiliquid material that sheds tiny metal particles from hard stones to keep them at their peak efficiency. It is recommended for use on hard stones such as our Ruby, India and Hard Arkansas Stones. Weighs ½ fl. oz.

Description	Item#	Each
Rub-and-Rinse	<b>813-1700</b>	<b>\$9.80</b>



**A**

**B, C Gesswein® Stoning and Lubricating Oil**

This special lubricant was developed for the mold and die finisher. It is economical and practically odorless, and it evaporates slowly. Recommended for fast cutting and for finishing operations. Helps prevent loading. Lets stones cut better and more freely so they produce a bright, smooth surface. Eliminates the need for hazardous kerosene. For use with diamond tools where lubrication is suggested. Viscosity: 38/45.

Description	Item#	Each
<b>B.</b> Pint (wide-mouth glass container)	<b>800-0100</b>	<b>\$8.95</b>
<b>C.</b> Gallon	<b>800-0110</b>	<b>20.75</b>



**B**

**C**

**D, E Norton® India Stone Oil**

Specifically formulated for use with sharpening stones. Will not load or gum up. Meets U.S. pharmaceutical standards for mineral oil purity and can be used around food preparation operations.

Description	Item#	Each
<b>D.</b> 4.5 oz.	<b>800-0121</b>	<b>\$4.95</b>
<b>E.</b> 1 pt.	<b>800-0122</b>	<b>9.50</b>



**D**

**E**

**F, G Syringe Dispensers**

Plastic syringes with 18-gauge stainless steel needles for pinpoint delivery of stoning oil to the exact place you want. Plunger works smoothly and slides evenly to prevent accidental flooding and sputtering. Constructed of polyethylene and polypropylene. Available in two sizes: 5 and 10cc. Each includes tip sheath and cover. Sold in packages of six.

Description	Item#	PKG. of 6	
		1-3	4+
<b>F.</b> 5cc Syringe	<b>811-2450</b>	<b>\$7.95</b>	<b>\$6.36</b>
<b>G.</b> 10cc Syringe	<b>811-2451</b>	<b>9.95</b>	<b>7.96</b>



**F**

**G**

**H Plastic Spray-Pump Bottle**

Use to dispense stoning oil, cleaning solution and more. Spray gets into hard-to-reach areas. Capacity: 4 fl. oz.

Description	Item#	PKG. of 6	
		1-3	3+
Plastic Spray-Pump Bottle	<b>811-2460</b>	<b>\$2.15</b>	<b>\$1.94</b>



**H**

**Gesswein® Blue Mounted Stones**



Available in plastic packages of 12 and boxes of 12, 36 or 72.

These superior quality stones are made of aluminum oxide bonded with porcelain-type clays, which provide the greatest strength and rigidity required for fast stock removal and longer life. The ceramic bond controls the release of the aluminum oxide abrasive grains. As each particle begins to dull, the bond discharges it, allowing new abrasive grain to surface with fresh, sharp cutting edges. Stones are securely bonded to their shanks and are guaranteed to run true.

Blue mounted stones can be dressed with our Tru-Stone #380-1030 (see p. 46). These hard stones hold their shapes exceptionally well. Recommended for use on hardened steel. **All are 120 (fine) grit** aluminum oxide with cobalt added to provide lubrication while grinding. They cut well and leave a smooth surface. All have 1½" long nickel-plated steel shanks. Shape dimensions shown in inches. For recommended speeds, consult the American National Standard Institute for full information on vitrified mounted wheels. Before using any abrasive product, follow all safe operating guidelines with respect to eye protection, hand protection, hearing protection and respiratory protection (see p. 304 for details). Also read the Material Safety Data Sheet (MSDS) to be aware of any inherent hazards or cautions.

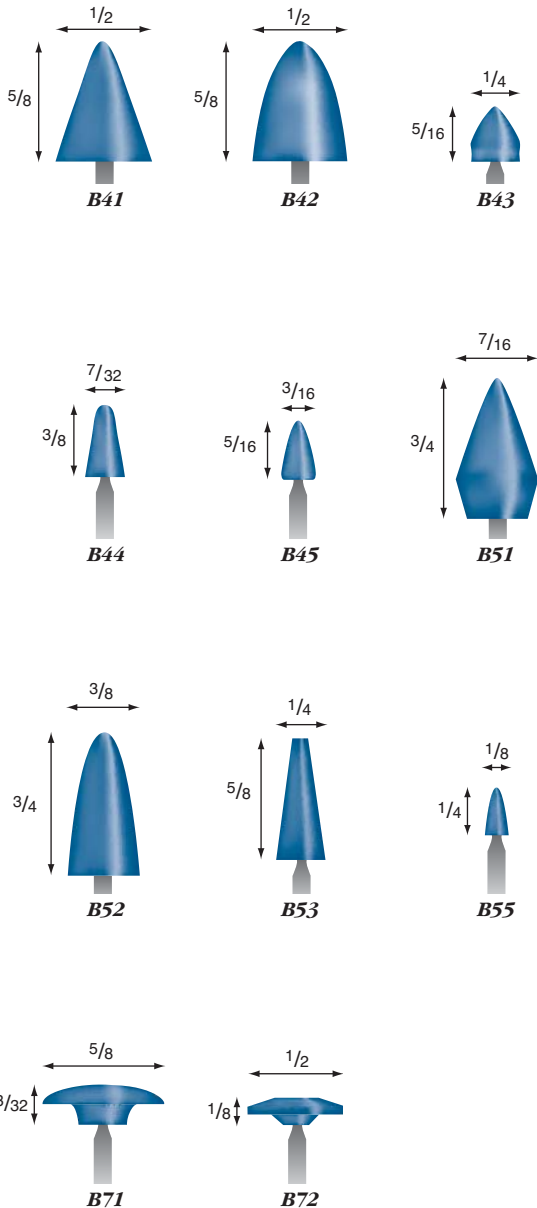

Style	Grit	Shank	Qty.	Item#	PKG./BOX Prices			
					1	2-3	4-9	10+
B41	120	1/8" 1/8" 3mm	Pkg. of 12	<b>304-0410</b>	<b>\$18.00</b>	—	—	—
			Box of 36	<b>300-0410</b>	<b>43.00</b>	<b>\$38.70</b>	<b>\$36.55</b>	<b>\$32.25</b>
			Box of 36	<b>308-0410</b>	<b>43.00</b>	<b>38.70</b>	<b>36.55</b>	<b>32.25</b>
B42	120	1/8" 1/8" 3mm	Pkg. of 12	<b>304-0420</b>	<b>19.00</b>	—	—	—
			Box of 36	<b>300-0420</b>	<b>45.00</b>	<b>40.50</b>	<b>38.25</b>	<b>33.75</b>
			Box of 36	<b>308-0420</b>	<b>45.00</b>	<b>40.50</b>	<b>38.25</b>	<b>33.75</b>
B43	120	1/8" 1/8" 3mm	Pkg. of 12	<b>304-0430</b>	<b>16.00</b>	—	—	—
			Box of 72	<b>300-0430</b>	<b>76.00</b>	<b>68.40</b>	<b>64.60</b>	<b>57.00</b>
			Box of 72	<b>308-0430</b>	<b>76.00</b>	<b>68.40</b>	<b>64.60</b>	<b>57.00</b>
B44	120	1/8" 1/8" 3mm	Pkg. of 12	<b>304-0440</b>	<b>16.00</b>	—	—	—
			Box of 72	<b>300-0440</b>	<b>76.00</b>	<b>68.40</b>	<b>64.60</b>	<b>57.00</b>
			Box of 72	<b>308-0440</b>	<b>76.00</b>	<b>68.40</b>	<b>64.60</b>	<b>57.00</b>
B45	120	1/8" 1/8" 3mm	Pkg. of 12	<b>304-0450</b>	<b>16.00</b>	—	—	—
			Box of 72	<b>300-0450</b>	<b>76.00</b>	<b>68.40</b>	<b>64.60</b>	<b>57.00</b>
			Box of 72	<b>308-0450</b>	<b>76.00</b>	<b>68.40</b>	<b>64.60</b>	<b>57.00</b>
B51	120	1/8" 1/8" 3mm	Pkg. of 12	<b>304-0510</b>	<b>19.00</b>	—	—	—
			Box of 72	<b>300-0510</b>	<b>90.00</b>	<b>81.00</b>	<b>76.50</b>	<b>67.50</b>
			Box of 72	<b>308-0510</b>	<b>90.00</b>	<b>81.00</b>	<b>76.50</b>	<b>67.50</b>
B52	120	1/8" 1/8" 3mm	Pkg. of 12	<b>304-0520</b>	<b>17.00</b>	—	—	—
			Box of 72	<b>300-0520</b>	<b>83.00</b>	<b>74.70</b>	<b>70.55</b>	<b>62.25</b>
			Box of 72	<b>308-0520</b>	<b>83.00</b>	<b>74.70</b>	<b>70.55</b>	<b>62.25</b>
B53	120	1/8" 1/8" 3mm	Pkg. of 12	<b>304-0530</b>	<b>17.00</b>	—	—	—
			Box of 72	<b>300-0530</b>	<b>83.00</b>	<b>74.70</b>	<b>70.55</b>	<b>62.25</b>
			Box of 72	<b>308-0530</b>	<b>83.00</b>	<b>74.70</b>	<b>70.55</b>	<b>62.25</b>
B55	120	1/8" 1/8" 3mm	Pkg. of 12	<b>304-0550</b>	<b>14.00</b>	—	—	—
			Box of 72	<b>300-0550</b>	<b>65.00</b>	<b>58.50</b>	<b>55.25</b>	<b>48.75</b>
			Box of 72	<b>308-0550</b>	<b>65.00</b>	<b>58.50</b>	<b>55.25</b>	<b>48.75</b>
B71	120	1/8" 1/8" 3mm	Pkg. of 12	<b>304-0710</b>	<b>17.00</b>	—	—	—
			Box of 36	<b>300-0710</b>	<b>42.00</b>	<b>37.80</b>	<b>35.70</b>	<b>31.50</b>
			Box of 36	<b>308-0710</b>	<b>42.00</b>	<b>37.80</b>	<b>35.70</b>	<b>31.50</b>
B72	120	1/8" 1/8" 3mm	Pkg. of 12	<b>304-0720</b>	<b>15.00</b>	—	—	—
			Box of 36	<b>300-0720</b>	<b>37.00</b>	<b>33.30</b>	<b>31.45</b>	<b>27.75</b>
			Box of 36	<b>308-0720</b>	<b>37.00</b>	<b>33.30</b>	<b>31.45</b>	<b>27.75</b>

**Gesswein® Blue Mounted Stones, cont'd**

Style	Grit	Shank	Qty.	Item#	PKG./BOX Prices			
					1	2-3	4-9	10+
B73	120	1/8"	Pkg. of 12	<b>304-0730</b>	<b>\$17.00</b>	—	—	—
		1/8"	Box of 36	<b>300-0730</b>	<b>42.00</b>	<b>\$37.80</b>	<b>\$35.70</b>	<b>\$31.50</b>
		3mm	Box of 36	<b>308-0730</b>	<b>42.00</b>	<b>37.80</b>	<b>35.70</b>	<b>31.50</b>
B81	120	1/8"	Box of 12	<b>300-0810</b>	<b>17.00</b>	<b>15.30</b>	<b>14.45</b>	<b>12.75</b>
		3mm	Box of 12	<b>308-0810</b>	<b>17.00</b>	<b>15.30</b>	<b>14.45</b>	<b>12.75</b>
B82	120	1/8"	Pkg. of 12	<b>304-0820</b>	<b>14.00</b>	—	—	—
		1/8"	Box of 36	<b>300-0820</b>	<b>33.00</b>	<b>29.70</b>	<b>28.05</b>	<b>24.75</b>
		3mm	Box of 36	<b>308-0820</b>	<b>33.00</b>	<b>29.70</b>	<b>28.05</b>	<b>24.75</b>
B84	120	1/8"	Pkg. of 12	<b>304-0840</b>	<b>14.00</b>	—	—	—
		1/8"	Box of 72	<b>300-0840</b>	<b>65.00</b>	<b>58.50</b>	<b>55.25</b>	<b>48.75</b>
		3mm	Box of 72	<b>308-0840</b>	<b>65.00</b>	<b>58.50</b>	<b>55.25</b>	<b>48.75</b>
B91	120	1/8"	Box of 12	<b>300-0910</b>	<b>17.00</b>	<b>15.30</b>	<b>14.45</b>	<b>12.75</b>
		3mm	Box of 12	<b>308-0910</b>	<b>17.00</b>	<b>15.30</b>	<b>14.45</b>	<b>12.75</b>
B92	120	1/8"	Pkg. of 12	<b>304-0920</b>	<b>14.00</b>	—	—	—
		1/8"	Box of 72	<b>300-0920</b>	<b>65.00</b>	<b>58.50</b>	<b>55.25</b>	<b>48.75</b>
		3mm	Box of 72	<b>308-0920</b>	<b>65.00</b>	<b>58.50</b>	<b>55.25</b>	<b>48.75</b>
B96	120	1/8"	Pkg. of 12	<b>304-0960</b>	<b>14.00</b>	—	—	—
		1/8"	Box of 72	<b>300-0960</b>	<b>65.00</b>	<b>58.50</b>	<b>55.25</b>	<b>48.75</b>
		3mm	Box of 72	<b>308-0960</b>	<b>65.00</b>	<b>58.50</b>	<b>55.25</b>	<b>48.75</b>
B97	120	1/8"	Pkg. of 12	<b>304-0970</b>	<b>16.00</b>	—	—	—
		1/8"	Box of 72	<b>300-0970</b>	<b>76.00</b>	<b>68.40</b>	<b>64.60</b>	<b>57.00</b>
		3mm	Box of 72	<b>308-0970</b>	<b>76.00</b>	<b>68.40</b>	<b>64.60</b>	<b>57.00</b>
B98	120	1/8"	Pkg. of 12	<b>304-0980</b>	<b>14.00</b>	—	—	—
		1/8"	Box of 72	<b>300-0980</b>	<b>65.00</b>	<b>58.50</b>	<b>55.25</b>	<b>48.75</b>
		3mm	Box of 72	<b>308-0980</b>	<b>65.00</b>	<b>58.50</b>	<b>55.25</b>	<b>48.75</b>
B101	120	1/8"	Box of 12	<b>300-1010</b>	<b>19.00</b>	<b>17.10</b>	<b>16.15</b>	<b>14.25</b>
		3mm	Box of 12	<b>308-1010</b>	<b>19.00</b>	<b>17.10</b>	<b>16.15</b>	<b>14.25</b>
B103	120	1/8"	Box of 12	<b>300-1030</b>	<b>17.00</b>	<b>15.30</b>	<b>14.45</b>	<b>12.75</b>
		3mm	Box of 12	<b>308-1030</b>	<b>17.00</b>	<b>15.30</b>	<b>14.45</b>	<b>12.75</b>
B104	120	1/8"	Pkg. of 12	<b>304-1040</b>	<b>16.00</b>	—	—	—
		1/8"	Box of 72	<b>300-1040</b>	<b>76.00</b>	<b>68.40</b>	<b>64.60</b>	<b>57.00</b>
		3mm	Box of 72	<b>308-1040</b>	<b>76.00</b>	<b>68.40</b>	<b>64.60</b>	<b>57.00</b>
B105	120	1/8"	Pkg. of 12	<b>304-1050</b>	<b>14.00</b>	—	—	—
		1/8"	Box of 72	<b>300-1050</b>	<b>65.00</b>	<b>58.50</b>	<b>55.25</b>	<b>48.75</b>
		3mm	Box of 72	<b>308-1050</b>	<b>65.00</b>	<b>58.50</b>	<b>55.25</b>	<b>48.75</b>
B111	120	1/8"	Pkg. of 12	<b>304-1110</b>	<b>19.00</b>	—	—	—
		1/8"	Box of 72	<b>300-1110</b>	<b>90.00</b>	<b>81.00</b>	<b>76.50</b>	<b>67.50</b>
		3mm	Box of 72	<b>308-1110</b>	<b>90.00</b>	<b>81.00</b>	<b>76.50</b>	<b>67.50</b>
B112	120	1/8"	Pkg. of 12	<b>304-1120</b>	<b>16.00</b>	—	—	—
		1/8"	Box of 72	<b>300-1120</b>	<b>76.00</b>	<b>68.40</b>	<b>64.60</b>	<b>57.00</b>
		3mm	Box of 72	<b>308-1120</b>	<b>76.00</b>	<b>68.40</b>	<b>64.60</b>	<b>57.00</b>
B121	120	1/8"	Pkg. of 12	<b>304-1210</b>	<b>16.00</b>	—	—	—
		1/8"	Box of 36	<b>300-1210</b>	<b>38.00</b>	<b>34.20</b>	<b>32.30</b>	<b>28.50</b>
		3mm	Box of 36	<b>308-1210</b>	<b>38.00</b>	<b>34.20</b>	<b>32.30</b>	<b>28.50</b>
B122	120	1/8"	Pkg. of 12	<b>304-1220</b>	<b>16.00</b>	—	—	—
		1/8"	Box of 72	<b>300-1220</b>	<b>76.00</b>	<b>68.40</b>	<b>64.60</b>	<b>57.00</b>
		3mm	Box of 72	<b>308-1220</b>	<b>76.00</b>	<b>68.40</b>	<b>64.60</b>	<b>57.00</b>
B123	120	1/8"	Pkg. of 12	<b>304-1230</b>	<b>14.00</b>	—	—	—
		1/8"	Box of 72	<b>300-1230</b>	<b>65.00</b>	<b>58.50</b>	<b>55.25</b>	<b>48.75</b>
		3mm	Box of 72	<b>308-1230</b>	<b>65.00</b>	<b>58.50</b>	<b>55.25</b>	<b>48.75</b>

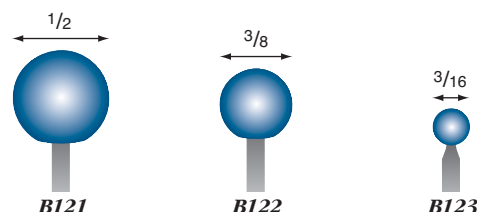
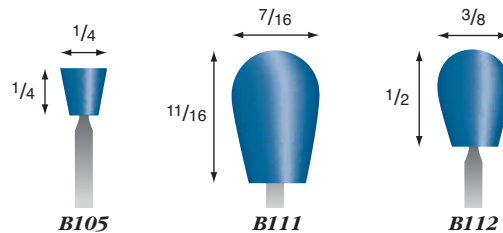
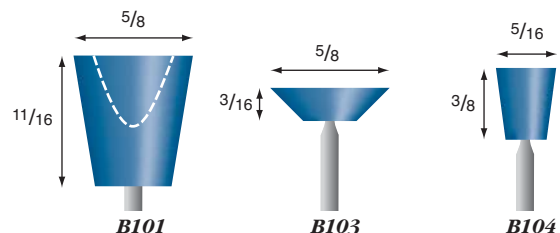
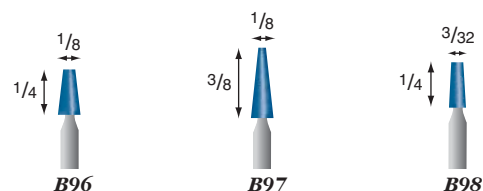
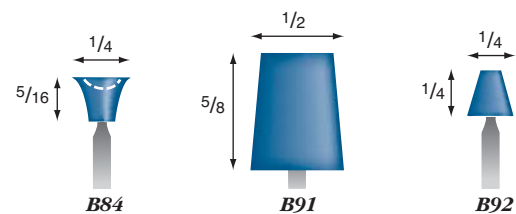
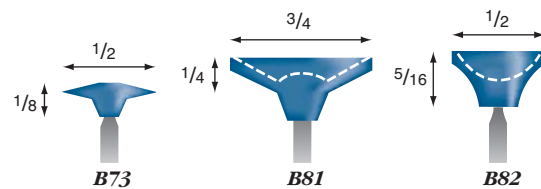

**Gesswein® Blue Mounted Stones, cont'd**

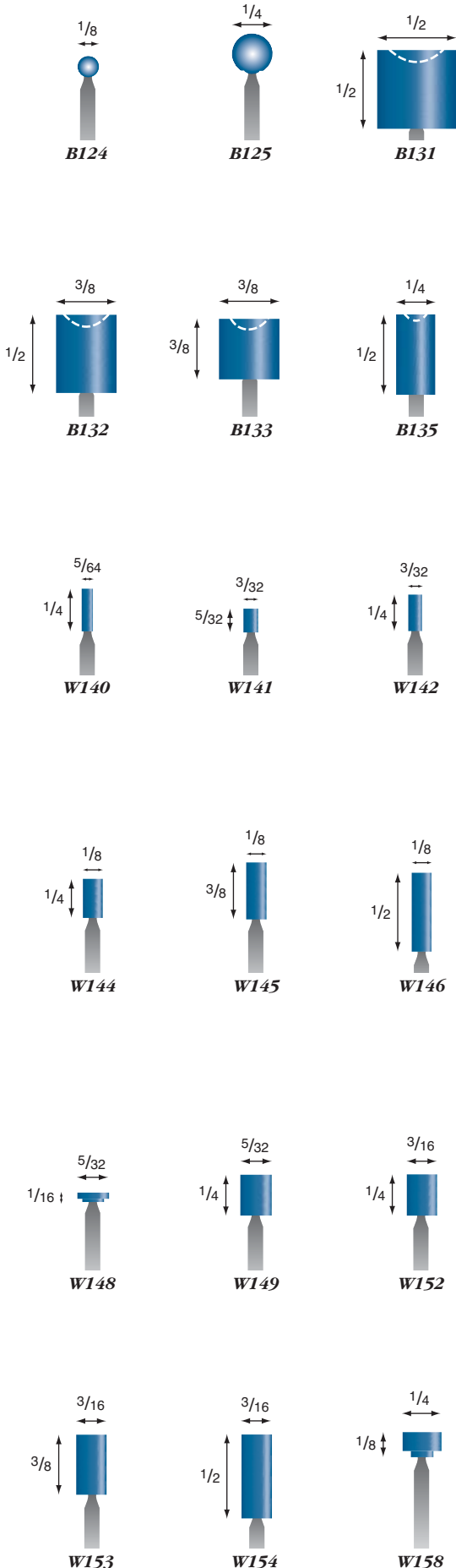

Style	Grit	Shank	Qty.	Item#	PKG./BOX Prices			
					1	2-3	4-9	10+
B124	120	1/8" 3mm	Pkg. of 12	<b>304-1240</b>	<b>\$14.00</b>	-	-	-
			Box of 72	<b>300-1240</b>	<b>65.00</b>	<b>\$58.50</b>	<b>\$55.25</b>	<b>\$48.75</b>
			Box of 72	<b>308-1240</b>	<b>65.00</b>	<b>58.50</b>	<b>55.25</b>	<b>48.75</b>
B125	120	1/8" 3mm	Pkg. of 12	<b>304-1250</b>	<b>16.00</b>	-	-	-
			Box of 72	<b>300-1250</b>	<b>78.00</b>	<b>70.20</b>	<b>66.30</b>	<b>58.50</b>
			Box of 72	<b>308-1250</b>	<b>78.00</b>	<b>70.20</b>	<b>66.30</b>	<b>58.50</b>
B131	120	1/8" 3mm	Pkg. of 12	<b>304-1310</b>	<b>11.00</b>	-	-	-
			Box of 36	<b>300-1310</b>	<b>27.00</b>	<b>24.30</b>	<b>22.95</b>	<b>20.25</b>
			Box of 36	<b>308-1310</b>	<b>27.00</b>	<b>24.30</b>	<b>22.95</b>	<b>20.25</b>
B132	120	1/8" 3mm	Pkg. of 12	<b>304-1320</b>	<b>11.00</b>	-	-	-
			Box of 72	<b>300-1320</b>	<b>55.00</b>	<b>49.50</b>	<b>46.75</b>	<b>41.25</b>
			Box of 72	<b>308-1320</b>	<b>55.00</b>	<b>49.50</b>	<b>46.75</b>	<b>41.25</b>
B133	120	1/8" 3mm	Pkg. of 12	<b>304-1330</b>	<b>11.00</b>	-	-	-
			Box of 72	<b>300-1330</b>	<b>55.00</b>	<b>49.50</b>	<b>46.75</b>	<b>41.25</b>
			Box of 72	<b>308-1330</b>	<b>55.00</b>	<b>49.50</b>	<b>46.75</b>	<b>41.25</b>
B135	120	1/8" 3mm	Pkg. of 12	<b>304-1350</b>	<b>11.00</b>	-	-	-
			Box of 72	<b>300-1350</b>	<b>55.00</b>	<b>49.50</b>	<b>46.75</b>	<b>41.25</b>
			Box of 72	<b>308-1350</b>	<b>55.00</b>	<b>49.50</b>	<b>46.75</b>	<b>41.25</b>
W140	120	1/8" 3mm	Pkg. of 12	<b>304-1400</b>	<b>10.00</b>	-	-	-
			Box of 72	<b>300-1400</b>	<b>48.00</b>	<b>43.20</b>	<b>40.80</b>	<b>36.00</b>
			Box of 72	<b>308-1400</b>	<b>48.00</b>	<b>43.20</b>	<b>40.80</b>	<b>36.00</b>
W141	120	1/8" 3mm	Pkg. of 12	<b>304-1410</b>	<b>11.00</b>	-	-	-
			Box of 72	<b>300-1410</b>	<b>51.00</b>	<b>45.90</b>	<b>43.35</b>	<b>38.25</b>
			Box of 72	<b>308-1410</b>	<b>51.00</b>	<b>45.90</b>	<b>43.35</b>	<b>38.25</b>
W142	120	1/8" 3mm	Pkg. of 12	<b>304-1420</b>	<b>11.00</b>	-	-	-
			Box of 72	<b>300-1420</b>	<b>51.00</b>	<b>45.90</b>	<b>43.35</b>	<b>38.25</b>
			Box of 72	<b>308-1420</b>	<b>51.00</b>	<b>45.90</b>	<b>43.35</b>	<b>38.25</b>
W144	120	1/8" 3mm	Pkg. of 12	<b>304-1440</b>	<b>11.00</b>	-	-	-
			Box of 72	<b>300-1440</b>	<b>51.00</b>	<b>45.90</b>	<b>43.35</b>	<b>38.25</b>
			Box of 72	<b>308-1440</b>	<b>51.00</b>	<b>45.90</b>	<b>43.35</b>	<b>38.25</b>
W145	120	1/8" 3mm	Pkg. of 12	<b>304-1450</b>	<b>11.00</b>	-	-	-
			Box of 72	<b>300-1450</b>	<b>55.00</b>	<b>49.50</b>	<b>46.75</b>	<b>41.25</b>
			Box of 72	<b>308-1450</b>	<b>55.00</b>	<b>49.50</b>	<b>46.75</b>	<b>41.25</b>
W146	120	1/8" 3mm	Pkg. of 12	<b>304-1460</b>	<b>11.00</b>	-	-	-
			Box of 72	<b>300-1460</b>	<b>55.00</b>	<b>49.50</b>	<b>46.75</b>	<b>41.25</b>
			Box of 72	<b>308-1460</b>	<b>55.00</b>	<b>49.50</b>	<b>46.75</b>	<b>41.25</b>
W148	120	1/8" 3mm	Pkg. of 12	<b>304-1480</b>	<b>11.00</b>	-	-	-
			Box of 72	<b>300-1480</b>	<b>55.00</b>	<b>49.50</b>	<b>46.75</b>	<b>41.25</b>
			Box of 72	<b>308-1480</b>	<b>55.00</b>	<b>49.50</b>	<b>46.75</b>	<b>41.25</b>
W149	120	1/8" 3mm	Pkg. of 12	<b>304-1490</b>	<b>11.00</b>	-	-	-
			Box of 72	<b>300-1490</b>	<b>51.00</b>	<b>45.90</b>	<b>43.35</b>	<b>38.25</b>
			Box of 72	<b>308-1490</b>	<b>51.00</b>	<b>45.90</b>	<b>43.35</b>	<b>38.25</b>
W152	120	1/8" 3mm	Pkg. of 12	<b>304-1520</b>	<b>11.00</b>	-	-	-
			Box of 72	<b>300-1520</b>	<b>51.00</b>	<b>45.90</b>	<b>43.35</b>	<b>38.25</b>
			Box of 72	<b>308-1520</b>	<b>51.00</b>	<b>45.90</b>	<b>43.35</b>	<b>38.25</b>
W153	120	1/8" 3mm	Pkg. of 12	<b>304-1530</b>	<b>11.00</b>	-	-	-
			Box of 72	<b>300-1530</b>	<b>55.00</b>	<b>49.50</b>	<b>46.75</b>	<b>41.25</b>
			Box of 72	<b>308-1530</b>	<b>55.00</b>	<b>49.50</b>	<b>46.75</b>	<b>41.25</b>
W154	120	1/8" 3mm	Pkg. of 12	<b>304-1540</b>	<b>11.00</b>	-	-	-
			Box of 72	<b>300-1540</b>	<b>55.00</b>	<b>49.50</b>	<b>46.75</b>	<b>41.25</b>
			Box of 72	<b>308-1540</b>	<b>55.00</b>	<b>49.50</b>	<b>46.75</b>	<b>41.25</b>
W158	120	1/8" 3mm	Pkg. of 12	<b>304-1580</b>	<b>11.00</b>	-	-	-
			Box of 72	<b>300-1580</b>	<b>51.00</b>	<b>45.90</b>	<b>43.35</b>	<b>38.25</b>
			Box of 72	<b>308-1580</b>	<b>51.00</b>	<b>45.90</b>	<b>43.35</b>	<b>38.25</b>



**Gesswein® Blue Mounted Stones, cont'd**

Style	Grit	Shank	Qty.	Item#	PKG./BOX Prices			
					1	2-3	4-9	10+
W160	120	1/8"	Pkg. of 12	<b>304-1600</b>	<b>\$11.00</b>	-	-	-
		1/8"	Box of 72	<b>300-1600</b>	<b>51.00</b>	<b>\$45.90</b>	<b>\$43.35</b>	<b>\$38.25</b>
		3mm	Box of 72	<b>308-1600</b>	<b>51.00</b>	<b>45.90</b>	<b>43.35</b>	<b>38.25</b>
W161	120	1/8"	Pkg. of 12	<b>304-1610</b>	<b>11.00</b>	-	-	-
		1/8"	Box of 72	<b>300-1610</b>	<b>55.00</b>	<b>49.50</b>	<b>46.75</b>	<b>41.25</b>
		3mm	Box of 72	<b>308-1610</b>	<b>55.00</b>	<b>49.50</b>	<b>46.75</b>	<b>41.25</b>
W162	120	1/8"	Pkg. of 12	<b>304-1620</b>	<b>11.00</b>	-	-	-
		1/8"	Box of 72	<b>300-1620</b>	<b>55.00</b>	<b>49.50</b>	<b>46.75</b>	<b>41.25</b>
		3mm	Box of 72	<b>308-1620</b>	<b>55.00</b>	<b>49.50</b>	<b>46.75</b>	<b>41.25</b>
W163	120	1/8"	Pkg. of 12	<b>304-1630</b>	<b>11.00</b>	-	-	-
		1/8"	Box of 72	<b>300-1630</b>	<b>55.00</b>	<b>49.50</b>	<b>46.75</b>	<b>41.25</b>
		3mm	Box of 72	<b>308-1630</b>	<b>55.00</b>	<b>49.50</b>	<b>46.75</b>	<b>41.25</b>
W164	120	1/8"	Pkg. of 12	<b>304-1640</b>	<b>12.00</b>	-	-	-
		1/8"	Box of 72	<b>300-1640</b>	<b>59.00</b>	<b>53.10</b>	<b>50.15</b>	<b>44.25</b>
		3mm	Box of 72	<b>308-1640</b>	<b>59.00</b>	<b>53.10</b>	<b>50.15</b>	<b>44.25</b>
W165	120	1/8"	Pkg. of 12	<b>304-1650</b>	<b>11.00</b>	-	-	-
		1/8"	Box of 72	<b>300-1650</b>	<b>51.00</b>	<b>45.90</b>	<b>43.35</b>	<b>38.25</b>
		3mm	Box of 72	<b>308-1650</b>	<b>51.00</b>	<b>45.90</b>	<b>43.35</b>	<b>38.25</b>
W168	120	1/8"	Pkg. of 12	<b>304-1680</b>	<b>11.00</b>	-	-	-
		1/8"	Box of 72	<b>300-1680</b>	<b>55.00</b>	<b>49.50</b>	<b>46.75</b>	<b>41.25</b>
		3mm	Box of 72	<b>308-1680</b>	<b>55.00</b>	<b>49.50</b>	<b>46.75</b>	<b>41.25</b>
W169	120	1/8"	Pkg. of 12	<b>304-1690</b>	<b>11.00</b>	-	-	-
		1/8"	Box of 72	<b>300-1690</b>	<b>55.00</b>	<b>49.50</b>	<b>46.75</b>	<b>41.25</b>
		3mm	Box of 72	<b>308-1690</b>	<b>55.00</b>	<b>49.50</b>	<b>46.75</b>	<b>41.25</b>
W170	120	1/8"	Pkg. of 12	<b>304-1700</b>	<b>11.00</b>	-	-	-
		1/8"	Box of 72	<b>300-1700</b>	<b>55.00</b>	<b>49.50</b>	<b>46.75</b>	<b>41.25</b>
		3mm	Box of 72	<b>308-1700</b>	<b>55.00</b>	<b>49.50</b>	<b>46.75</b>	<b>41.25</b>
W171	120	1/8"	Pkg. of 12	<b>304-1710</b>	<b>12.00</b>	-	-	-
		1/8"	Box of 72	<b>300-1710</b>	<b>59.00</b>	<b>53.10</b>	<b>50.15</b>	<b>44.25</b>
		3mm	Box of 72	<b>308-1710</b>	<b>59.00</b>	<b>53.10</b>	<b>50.15</b>	<b>44.25</b>
W174	120	1/8"	Pkg. of 12	<b>304-1740</b>	<b>11.00</b>	-	-	-
		1/8"	Box of 72	<b>300-1740</b>	<b>55.00</b>	<b>49.50</b>	<b>46.75</b>	<b>41.25</b>
		3mm	Box of 72	<b>308-1740</b>	<b>55.00</b>	<b>49.50</b>	<b>46.75</b>	<b>41.25</b>
W175	120	1/8"	Pkg. of 12	<b>304-1750</b>	<b>11.00</b>	-	-	-
		1/8"	Box of 72	<b>300-1750</b>	<b>55.00</b>	<b>49.50</b>	<b>46.75</b>	<b>41.25</b>
		3mm	Box of 72	<b>308-1750</b>	<b>55.00</b>	<b>49.50</b>	<b>46.75</b>	<b>41.25</b>
W176	120	1/8"	Pkg. of 12	<b>304-1760</b>	<b>11.00</b>	-	-	-
		1/8"	Box of 72	<b>300-1760</b>	<b>55.00</b>	<b>49.50</b>	<b>46.75</b>	<b>41.25</b>
		3mm	Box of 72	<b>308-1760</b>	<b>55.00</b>	<b>49.50</b>	<b>46.75</b>	<b>41.25</b>
W178	120	1/8"	Pkg. of 12	<b>304-1780</b>	<b>14.00</b>	-	-	-
		1/8"	Box of 72	<b>300-1780</b>	<b>65.00</b>	<b>58.50</b>	<b>55.25</b>	<b>48.75</b>
		3mm	Box of 72	<b>308-1780</b>	<b>65.00</b>	<b>58.50</b>	<b>55.25</b>	<b>48.75</b>
W181	120	1/8"	Pkg. of 12	<b>304-1810</b>	<b>11.00</b>	-	-	-
		1/8"	Box of 36	<b>300-1810</b>	<b>26.00</b>	<b>23.40</b>	<b>22.10</b>	<b>19.50</b>
		3mm	Box of 36	<b>308-1810</b>	<b>26.00</b>	<b>23.40</b>	<b>22.10</b>	<b>19.50</b>
W182	120	1/8"	Pkg. of 12	<b>304-1820</b>	<b>11.00</b>	-	-	-
		1/8"	Box of 36	<b>300-1820</b>	<b>26.00</b>	<b>23.40</b>	<b>22.10</b>	<b>19.50</b>
		3mm	Box of 36	<b>308-1820</b>	<b>26.00</b>	<b>23.40</b>	<b>22.10</b>	<b>19.50</b>
W183	120	1/8"	Pkg. of 12	<b>304-1830</b>	<b>11.00</b>	-	-	-
		1/8"	Box of 36	<b>300-1830</b>	<b>26.00</b>	<b>23.40</b>	<b>22.10</b>	<b>19.50</b>
		3mm	Box of 36	<b>308-1830</b>	<b>26.00</b>	<b>23.40</b>	<b>22.10</b>	<b>19.50</b>
W184	120	1/8"	Pkg. of 12	<b>304-1840</b>	<b>11.00</b>	-	-	-
		1/8"	Box of 36	<b>300-1840</b>	<b>27.00</b>	<b>24.30</b>	<b>22.95</b>	<b>20.25</b>
		3mm	Box of 36	<b>308-1840</b>	<b>27.00</b>	<b>24.30</b>	<b>22.95</b>	<b>20.25</b>

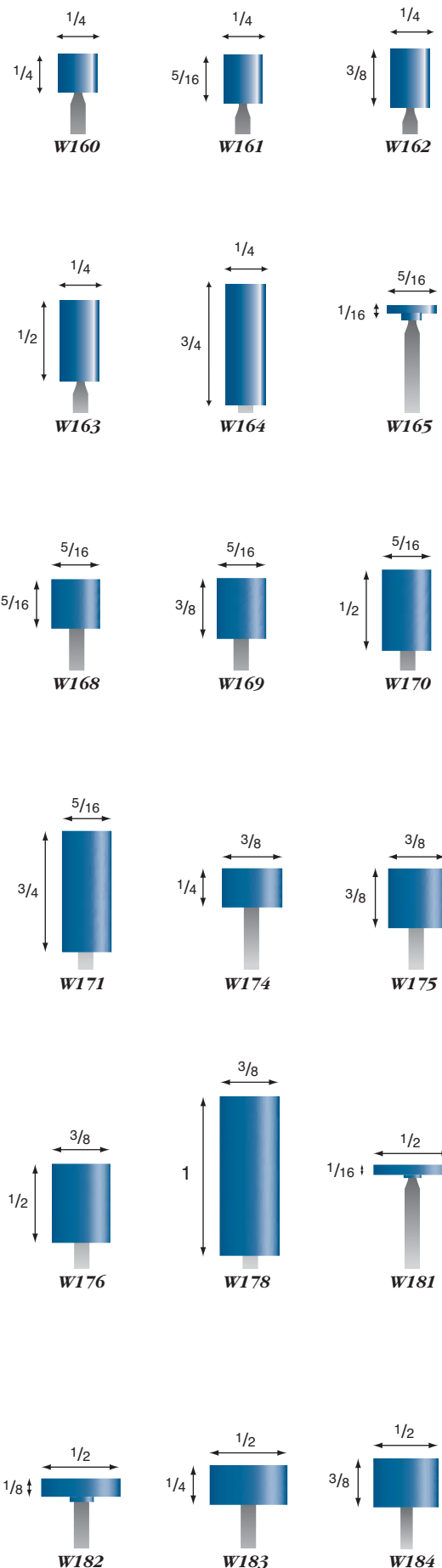

## Gesswein® Blue Mounted Stones, cont'd

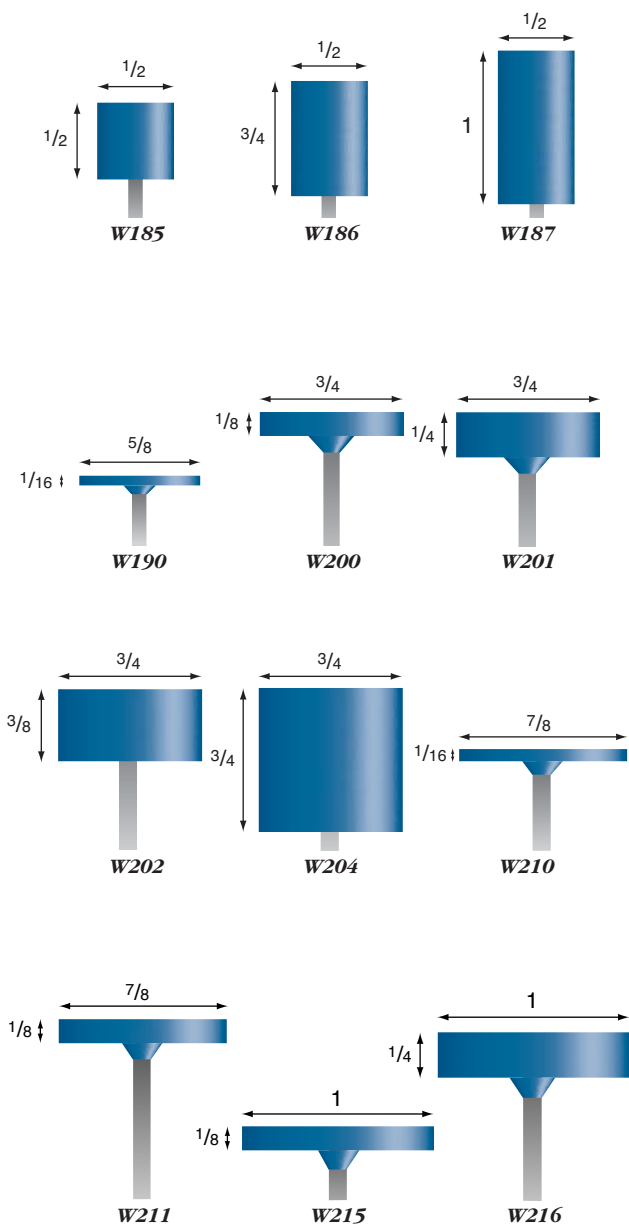

Style	Grit	Shank	Qty.	Item#	PKG./BOX Prices			
					1	2-3	4-9	10+
W185	120	1/8" 3mm	Pkg. of 12	<b>304-1850</b>	<b>\$11.00</b>	-	-	-
			Box of 36	<b>300-1850</b>	<b>27.00</b>	<b>\$24.30</b>	<b>\$22.95</b>	<b>\$20.25</b>
			Box of 36	<b>308-1850</b>	<b>27.00</b>	<b>24.30</b>	<b>22.95</b>	<b>20.25</b>
W186	120	1/8" 3mm	Pkg. of 12	<b>304-1860</b>	<b>12.00</b>	-	-	-
			Box of 36	<b>300-1860</b>	<b>29.00</b>	<b>26.10</b>	<b>24.65</b>	<b>21.75</b>
			Box of 36	<b>308-1860</b>	<b>29.00</b>	<b>26.10</b>	<b>24.65</b>	<b>21.75</b>
W187	120	1/8" 3mm	Pkg. of 12	<b>304-1870</b>	<b>14.00</b>	-	-	-
			Box of 36	<b>300-1870</b>	<b>33.00</b>	<b>29.70</b>	<b>28.05</b>	<b>24.75</b>
			Box of 36	<b>308-1870</b>	<b>33.00</b>	<b>29.70</b>	<b>28.05</b>	<b>24.75</b>
W190	120	1/8" 3mm	Pkg. of 12	<b>304-1900</b>	<b>11.00</b>	-	-	-
			Box of 36	<b>300-1900</b>	<b>27.00</b>	<b>24.30</b>	<b>22.95</b>	<b>20.25</b>
			Box of 36	<b>308-1900</b>	<b>27.00</b>	<b>24.30</b>	<b>22.95</b>	<b>20.25</b>
W200	120	1/8" 3mm	Box of 12	<b>300-2000</b>	<b>11.00</b>	<b>9.90</b>	<b>9.35</b>	<b>8.25</b>
			Box of 12	<b>308-2000</b>	<b>11.00</b>	<b>9.90</b>	<b>9.35</b>	<b>8.25</b>
W201	120	1/8" 3mm	Box of 12	<b>300-2010</b>	<b>11.00</b>	<b>9.90</b>	<b>9.35</b>	<b>8.25</b>
			Box of 12	<b>308-2010</b>	<b>11.00</b>	<b>9.90</b>	<b>9.35</b>	<b>8.25</b>
W202	120	1/8" 3mm	Box of 12	<b>300-2020</b>	<b>13.00</b>	<b>11.70</b>	<b>11.05</b>	<b>9.75</b>
			Box of 12	<b>308-2020</b>	<b>13.00</b>	<b>11.70</b>	<b>11.05</b>	<b>9.75</b>
W204	120	1/8" 3mm	Box of 12	<b>300-2040</b>	<b>15.00</b>	<b>13.50</b>	<b>12.75</b>	<b>11.25</b>
			Box of 12	<b>308-2040</b>	<b>15.00</b>	<b>13.50</b>	<b>12.75</b>	<b>11.25</b>
W210	120	1/8" 3mm	Box of 12	<b>300-2100</b>	<b>13.00</b>	<b>11.70</b>	<b>11.05</b>	<b>9.75</b>
			Box of 12	<b>308-2100</b>	<b>13.00</b>	<b>11.70</b>	<b>11.05</b>	<b>9.75</b>
W211	120	1/8" 3mm	Box of 12	<b>300-2110</b>	<b>13.00</b>	<b>11.70</b>	<b>11.05</b>	<b>9.75</b>
			Box of 12	<b>308-2110</b>	<b>13.00</b>	<b>11.70</b>	<b>11.05</b>	<b>9.75</b>
W215	120	1/8" 3mm	Box of 12	<b>300-2150</b>	<b>13.00</b>	<b>11.70</b>	<b>11.05</b>	<b>9.75</b>
			Box of 12	<b>308-2150</b>	<b>13.00</b>	<b>11.70</b>	<b>11.05</b>	<b>9.75</b>
W216	120	1/8" 3mm	Box of 12	<b>300-2160</b>	<b>13.00</b>	<b>11.70</b>	<b>11.05</b>	<b>9.75</b>
			Box of 12	<b>308-2160</b>	<b>13.00</b>	<b>11.70</b>	<b>11.05</b>	<b>9.75</b>

### **A, B** Gesswein® Blue Mounted Stone Sets – 1/8" Shank

Gesswein Blue Mounted Stones are available in money-saving sets of 48 and 100 pieces. These assortments are made from our most popular shapes and offer a stone for almost every application. These sets offer big savings from the one-piece prices.

The 100-Piece Set includes ten each of our ten most popular shapes, conveniently packaged in a box to hold all 100 stones. Ten each of the following shapes: B44, B52, B96, B123, W144, W152, W162, W170, W175, W200.

The 48-Piece Set includes six each of eight popular shapes, conveniently packaged in a box to hold all 48 stones. Six each of the following shapes: B44, B52, B123, W144, W152, W162, W176, W200.



Description	Item#	Each
<b>A.</b> 100-Piece Blue Mounted Stone Set	<b>305-3000</b>	<b>\$95.00</b>
<b>B.</b> 48-Piece Blue Mounted Stone Set	<b>305-3010</b>	<b>46.00</b>

### Gesswein® Red Mounted Stones

These superior quality stones are made of aluminum oxide bonded with porcelain-type clays, which provide the greatest strength and rigidity required for fast stock removal and longer life. The ceramic bond controls the release of the aluminum oxide abrasive grains. As each particle begins to dull, the bond discharges it, allowing new abrasive grain to surface with fresh, sharp cutting edges. Stones are securely bonded to their shanks and are guaranteed to run true.

Red mounted stones can be dressed with our Tru-Stone #380-1030 (see p. 46). These fast-cutting, nonloading stones are easily identified by their reddish-brown color. **The grit varies between 60, 80 (medium) and 100 (fine).** For fast grinding of medium and hard materials. Ideal for internal grinding of tools, dies and gauges. All have 1½" L nickel-plated steel shanks. Shape dimensions shown in inches. For recommended speeds, consult the American National Standard Institute for full information on vitrified mounted wheels. Before using any abrasive product, follow all safe operating guidelines with respect to eye protection, hand protection, hearing protection and respiratory protection (see p. 304 for details). Also read the Material Safety Data Sheet (MSDS) to be aware of any inherent hazards or cautions.



Available in plastic packages of 12 and boxes of 12, 36 or 72.

Style	Grit	Shank	Qty.	Item#	PKG./BOX Prices			
					1	2-3	4-9	10+
B41	60	1/8"	Pkg. of 12	<b>309-0410</b>	<b>\$18.00</b>	-	-	-
			Box of 36	<b>301-0410</b>	<b>43.00</b>	<b>\$38.70</b>	<b>\$36.55</b>	<b>\$32.25</b>
B42	60	1/8"	Pkg. of 12	<b>309-0420</b>	<b>19.00</b>	-	-	-
			Box of 36	<b>301-0420</b>	<b>45.00</b>	<b>40.50</b>	<b>38.25</b>	<b>33.75</b>
			Box of 36	<b>313-0420</b>	<b>45.00</b>	<b>40.50</b>	<b>38.25</b>	<b>33.75</b>
B43	60	1/8"	Pkg. of 12	<b>309-0430</b>	<b>16.00</b>	-	-	-
			Box of 72	<b>301-0430</b>	<b>76.00</b>	<b>68.40</b>	<b>64.60</b>	<b>57.00</b>
B44	60	1/8"	Pkg. of 12	<b>309-0440</b>	<b>16.00</b>	-	-	-
			Box of 72	<b>301-0440</b>	<b>76.00</b>	<b>68.40</b>	<b>64.60</b>	<b>57.00</b>
			Box of 72	<b>313-0440</b>	<b>76.00</b>	<b>68.40</b>	<b>64.60</b>	<b>57.00</b>
B45	60	1/8"	Pkg. of 12	<b>309-0450</b>	<b>16.00</b>	-	-	-
			Box of 72	<b>301-0450</b>	<b>76.00</b>	<b>68.40</b>	<b>64.60</b>	<b>57.00</b>
B51	60	1/8"	Pkg. of 12	<b>309-0510</b>	<b>19.00</b>	-	-	-
			Box of 72	<b>301-0510</b>	<b>90.00</b>	<b>81.00</b>	<b>76.50</b>	<b>67.50</b>
B52	60	1/8"	Pkg. of 12	<b>309-0520</b>	<b>17.00</b>	-	-	-
			Box of 72	<b>301-0520</b>	<b>83.00</b>	<b>74.70</b>	<b>70.55</b>	<b>62.25</b>
			Box of 72	<b>313-0520</b>	<b>83.00</b>	<b>74.70</b>	<b>70.55</b>	<b>62.25</b>
B53	60	1/8"	Pkg. of 12	<b>309-0530</b>	<b>17.00</b>	-	-	-
			Box of 72	<b>301-0530</b>	<b>83.00</b>	<b>74.70</b>	<b>70.55</b>	<b>62.25</b>
B55	60	1/8"	Pkg. of 12	<b>309-0550</b>	<b>14.00</b>	-	-	-
			Box of 72	<b>301-0550</b>	<b>65.00</b>	<b>58.50</b>	<b>55.25</b>	<b>48.75</b>
B71	60	1/8"	Pkg. of 12	<b>309-0710</b>	<b>17.00</b>	-	-	-
			Box of 36	<b>301-0710</b>	<b>42.00</b>	<b>37.80</b>	<b>35.70</b>	<b>31.50</b>
B72	60	1/8"	Pkg. of 12	<b>309-0720</b>	<b>15.00</b>	-	-	-
			Box of 36	<b>301-0720</b>	<b>37.00</b>	<b>33.30</b>	<b>31.45</b>	<b>27.75</b>

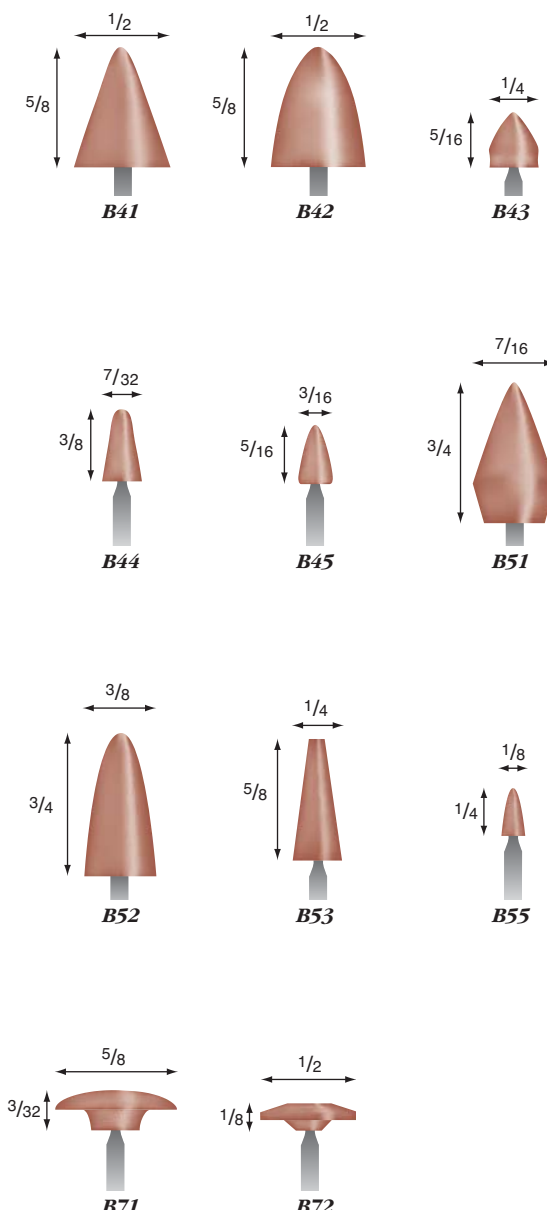

## Gesswein® Red Mounted Stones, cont'd

Style	Grit	Shank	Qty.	Item#	1	PKG./BOX Prices			
						2-3	4-9	10+	
B73	60	1/8" 3mm	Pkg. of 12	<b>309-0730</b>	<b>\$17.00</b>	-	-	-	
			Box of 36	<b>301-0730</b>	<b>42.00</b>	<b>\$37.80</b>	<b>\$35.70</b>	<b>\$31.50</b>	
			Box of 36	<b>313-0730</b>	<b>42.00</b>	<b>37.80</b>	<b>35.70</b>	<b>31.50</b>	
B81	60	1/8"	Box of 12	<b>301-0810</b>	<b>17.00</b>	<b>15.30</b>	<b>14.45</b>	<b>12.75</b>	
B82	80	1/8" 1/8"	Pkg. of 12	<b>309-0820</b>	<b>14.00</b>	-	-	-	
			Box of 36	<b>301-0820</b>	<b>33.00</b>	<b>29.70</b>	<b>28.05</b>	<b>24.75</b>	
B84	80	1/8" 1/8"	Pkg. of 12	<b>309-0840</b>	<b>14.00</b>	-	-	-	
			Box of 72	<b>301-0840</b>	<b>65.00</b>	<b>58.50</b>	<b>55.25</b>	<b>48.75</b>	
B91	60	1/8" 3mm	Box of 12	<b>301-0910</b>	<b>17.00</b>	<b>15.30</b>	<b>14.45</b>	<b>12.75</b>	
			Box of 12	<b>313-0910</b>	<b>17.00</b>	<b>15.30</b>	<b>14.45</b>	<b>12.75</b>	
B92	60	1/8" 1/8" 3mm	Pkg. of 12	<b>309-0920</b>	<b>14.00</b>	-	-	-	
			Box of 72	<b>301-0920</b>	<b>65.00</b>	<b>58.50</b>	<b>55.25</b>	<b>48.75</b>	
			Box of 72	<b>313-0920</b>	<b>65.00</b>	<b>58.50</b>	<b>55.25</b>	<b>48.75</b>	
B96	60	1/8" 1/8"	Pkg. of 12	<b>309-0960</b>	<b>14.00</b>	-	-	-	
			Box of 72	<b>301-0960</b>	<b>65.00</b>	<b>58.50</b>	<b>55.25</b>	<b>48.75</b>	
B97	60	1/8" 1/8" 3mm	Pkg. of 12	<b>309-0970</b>	<b>16.00</b>	-	-	-	
			Box of 72	<b>301-0970</b>	<b>76.00</b>	<b>68.40</b>	<b>64.60</b>	<b>57.00</b>	
			Box of 72	<b>313-0970</b>	<b>76.00</b>	<b>68.40</b>	<b>64.60</b>	<b>57.00</b>	
B98	60	1/8" 1/8"	Pkg. of 12 Box of 72	<b>309-0980</b> <b>301-0980</b>	<b>14.00</b> <b>65.00</b>	- <b>58.50</b>	- <b>55.25</b>	- <b>48.75</b>	
B101	60	1/8"	Box of 12	<b>301-1010</b>	<b>19.00</b>	<b>17.10</b>	<b>16.15</b>	<b>14.25</b>	
B103	60	1/8"	Box of 12	<b>301-1030</b>	<b>17.00</b>	<b>15.30</b>	<b>14.45</b>	<b>12.75</b>	
B104	60	1/8" 1/8"	Pkg. of 12	<b>309-1040</b>	<b>16.00</b>	-	-	-	
			Box of 72	<b>301-1040</b>	<b>76.00</b>	<b>68.40</b>	<b>64.60</b>	<b>57.00</b>	
B105	100	1/8" 1/8"	Pkg. of 12	<b>309-1050</b>	<b>14.00</b>	-	-	-	
			Box of 72	<b>301-1050</b>	<b>65.00</b>	<b>58.50</b>	<b>55.25</b>	<b>48.75</b>	
B111	80	1/8" 1/8"	Pkg. of 12	<b>309-1110</b>	<b>19.00</b>	-	-	-	
			Box of 72	<b>301-1110</b>	<b>90.00</b>	<b>81.00</b>	<b>76.50</b>	<b>67.50</b>	
B112	100	1/8" 1/8"	Pkg. of 12	<b>309-1120</b>	<b>16.00</b>	-	-	-	
			Box of 72	<b>301-1120</b>	<b>76.00</b>	<b>68.40</b>	<b>64.60</b>	<b>57.00</b>	
B121	60	1/8" 1/8"	Pkg. of 12	<b>309-1210</b>	<b>16.00</b>	-	-	-	
			Box of 36	<b>301-1210</b>	<b>38.00</b>	<b>34.20</b>	<b>32.30</b>	<b>28.50</b>	
B122	60	1/8" 1/8"	Pkg. of 12	<b>309-1220</b>	<b>16.00</b>	-	-	-	
			Box of 72	<b>301-1220</b>	<b>76.00</b>	<b>68.40</b>	<b>64.60</b>	<b>57.00</b>	
B123	80	1/8" 1/8" 3mm	Pkg. of 12	<b>309-1230</b>	<b>14.00</b>	-	-	-	
			Box of 72	<b>301-1230</b>	<b>65.00</b>	<b>58.50</b>	<b>55.25</b>	<b>48.75</b>	
			Box of 72	<b>313-1230</b>	<b>65.00</b>	<b>58.50</b>	<b>55.25</b>	<b>48.75</b>	

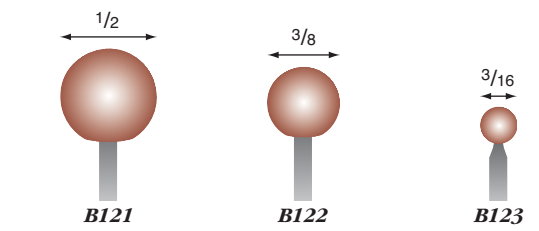
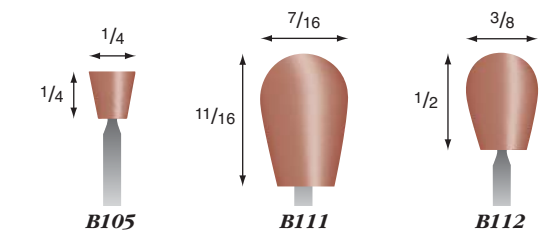
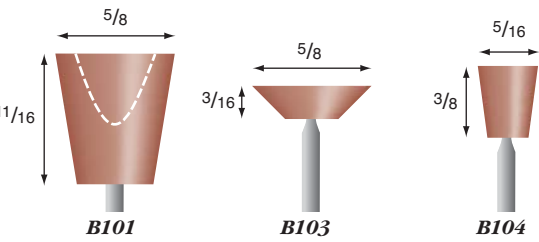
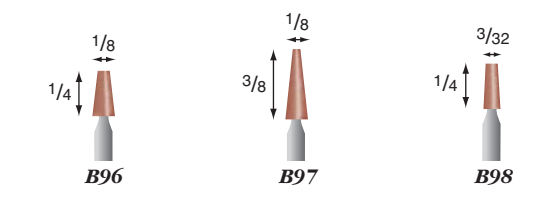
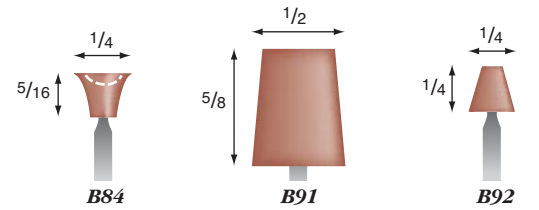
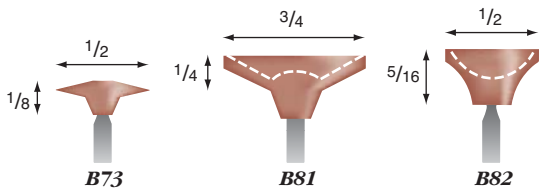



**Gesswein® Red Mounted Stones, cont'd**

Style	Grit	Shank	Qty.	Item#	PKG./BOX Prices			
					1	2-3	4-9	10+
B124	80	1/8" 1/8"	Pkg. of 12	<b>309-1240</b>	<b>\$14.00</b>	—	—	—
			Box of 72	<b>301-1240</b>	<b>65.00</b>	<b>\$58.50</b>	<b>\$55.25</b>	<b>\$48.75</b>
B125	80	1/8" 1/8"	Pkg. of 12	<b>309-1250</b>	<b>16.00</b>	—	—	—
			Box of 72	<b>301-1250</b>	<b>78.00</b>	<b>70.20</b>	<b>66.30</b>	<b>58.50</b>
B131	80	1/8" 1/8"	Pkg. of 12	<b>309-1310</b>	<b>11.00</b>	—	—	—
			Box of 72	<b>301-1310</b>	<b>27.00</b>	<b>24.30</b>	<b>22.95</b>	<b>20.25</b>
B132	80	1/8" 1/8"	Pkg. of 12	<b>309-1320</b>	<b>11.00</b>	—	—	—
			Box of 72	<b>301-1320</b>	<b>55.00</b>	<b>49.50</b>	<b>46.75</b>	<b>41.25</b>
B133	80	1/8" 1/8"	Pkg. of 12	<b>309-1330</b>	<b>11.00</b>	—	—	—
			Box of 72	<b>301-1330</b>	<b>55.00</b>	<b>49.50</b>	<b>46.75</b>	<b>41.25</b>
B135	80	1/8" 1/8"	Pkg. of 12	<b>309-1350</b>	<b>11.00</b>	—	—	—
			Box of 72	<b>301-1350</b>	<b>55.00</b>	<b>49.50</b>	<b>46.75</b>	<b>41.25</b>
W140	100	1/8"	Pkg. of 12	<b>309-1400</b>	<b>10.00</b>	—	—	—
		1/8"	Box of 72	<b>301-1400</b>	<b>48.00</b>	<b>43.20</b>	<b>40.80</b>	<b>36.00</b>
		3mm	Box of 72	<b>313-1400</b>	<b>48.00</b>	<b>43.20</b>	<b>40.80</b>	<b>36.00</b>
W141	100	1/8" 1/8"	Pkg. of 12	<b>309-1410</b>	<b>11.00</b>	—	—	—
			Box of 72	<b>301-1410</b>	<b>51.00</b>	<b>45.90</b>	<b>43.35</b>	<b>38.25</b>
W142	100	1/8"	Pkg. of 12	<b>309-1420</b>	<b>11.00</b>	—	—	—
		1/8"	Box of 72	<b>301-1420</b>	<b>51.00</b>	<b>45.90</b>	<b>43.35</b>	<b>38.25</b>
		3mm	Box of 72	<b>313-1420</b>	<b>51.00</b>	<b>45.90</b>	<b>43.35</b>	<b>38.25</b>
W144	80	1/8"	Pkg. of 12	<b>309-1440</b>	<b>11.00</b>	—	—	—
		1/8"	Box of 72	<b>301-1440</b>	<b>51.00</b>	<b>45.90</b>	<b>43.35</b>	<b>38.25</b>
		3mm	Box of 72	<b>313-1440</b>	<b>51.00</b>	<b>45.90</b>	<b>43.35</b>	<b>38.25</b>
W145	80	1/8" 1/8"	Pkg. of 12	<b>309-1450</b>	<b>11.00</b>	—	—	—
			Box of 72	<b>301-1450</b>	<b>55.00</b>	<b>49.50</b>	<b>46.75</b>	<b>41.25</b>
W146	80	1/8" 1/8"	Pkg. of 12	<b>309-1460</b>	<b>11.00</b>	—	—	—
			Box of 72	<b>301-1460</b>	<b>55.00</b>	<b>49.50</b>	<b>46.75</b>	<b>41.25</b>
W148	80	1/8" 1/8"	Pkg. of 12	<b>309-1480</b>	<b>11.00</b>	—	—	—
			Box of 72	<b>301-1480</b>	<b>55.00</b>	<b>49.50</b>	<b>46.75</b>	<b>41.25</b>
W149	80	1/8" 1/8"	Pkg. of 12	<b>309-1490</b>	<b>11.00</b>	—	—	—
			Box of 72	<b>301-1490</b>	<b>51.00</b>	<b>45.90</b>	<b>43.35</b>	<b>38.25</b>
W152	80	1/8"	Pkg. of 12	<b>309-1520</b>	<b>11.00</b>	—	—	—
		1/8"	Box of 72	<b>301-1520</b>	<b>51.00</b>	<b>45.90</b>	<b>43.35</b>	<b>38.25</b>
		3mm	Box of 72	<b>313-1520</b>	<b>51.00</b>	<b>45.90</b>	<b>43.35</b>	<b>38.25</b>
W153	80	1/8" 1/8"	Pkg. of 12	<b>309-1530</b>	<b>11.00</b>	—	—	—
			Box of 72	<b>301-1530</b>	<b>55.00</b>	<b>49.50</b>	<b>46.75</b>	<b>41.25</b>
W154	80	1/8"	Pkg. of 12	<b>309-1540</b>	<b>11.00</b>	—	—	—
		1/8"	Box of 72	<b>301-1540</b>	<b>55.00</b>	<b>49.50</b>	<b>46.75</b>	<b>41.25</b>
		3mm	Box of 72	<b>313-1540</b>	<b>55.00</b>	<b>49.50</b>	<b>46.75</b>	<b>41.25</b>
W158	80	1/8" 1/8"	Pkg. of 12	<b>309-1580</b>	<b>11.00</b>	—	—	—
			Box of 72	<b>301-1580</b>	<b>51.00</b>	<b>45.90</b>	<b>43.35</b>	<b>38.25</b>

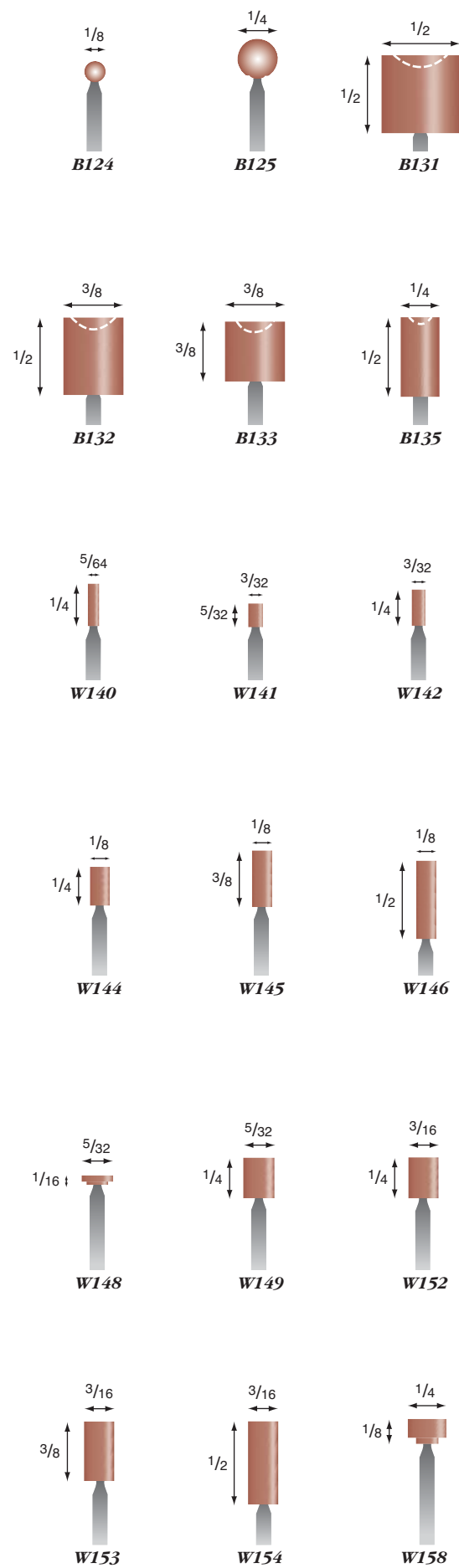

## Gesswein® Red Mounted Stones, cont'd

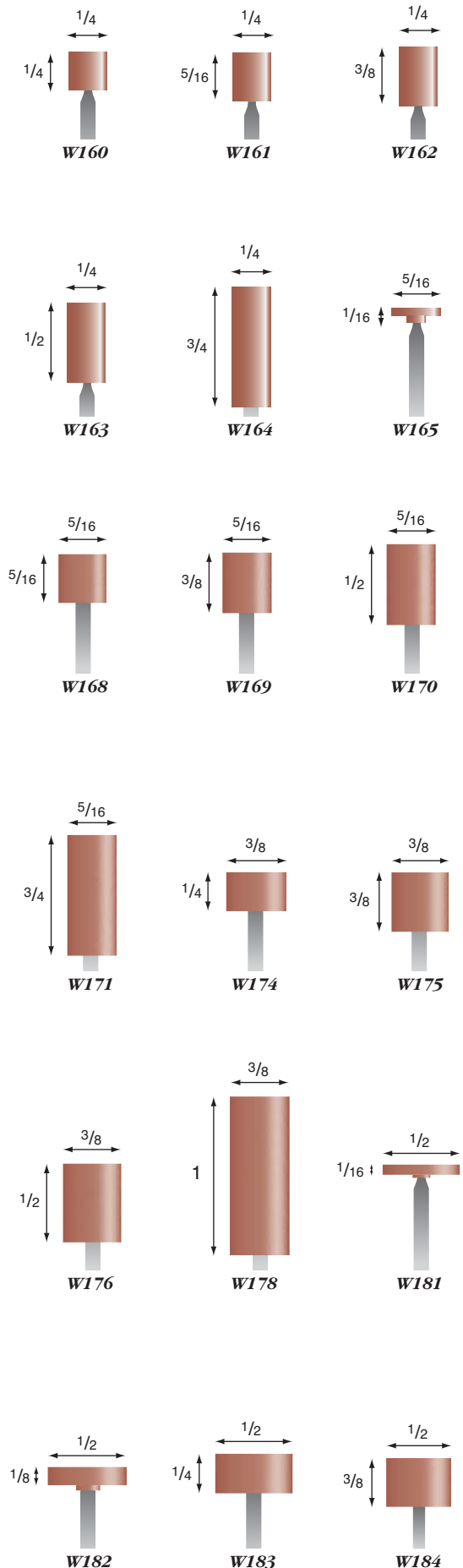

Style	Grit	Shank	Qty.	Item#	1	PKG./BOX Prices			
						2-3	4-9	10+	
W160	80	1/8"	Pkg. of 12	<b>309-1600</b>	<b>\$11.00</b>	-	-	-	
			Box of 36	<b>301-1600</b>	<b>51.00</b>	<b>\$45.90</b>	<b>\$43.35</b>	<b>\$38.25</b>	
W161	80	1/8"	Pkg. of 12	<b>309-1610</b>	<b>11.00</b>	-	-	-	
			Box of 72	<b>301-1610</b>	<b>55.00</b>	<b>49.50</b>	<b>46.75</b>	<b>41.25</b>	
W162	80	1/8"	Pkg. of 12	<b>309-1620</b>	<b>11.00</b>	-	-	-	
			Box of 72	<b>301-1620</b>	<b>55.00</b>	<b>49.50</b>	<b>46.75</b>	<b>41.25</b>	
W163	80	1/8"	Pkg. of 12	<b>309-1630</b>	<b>11.00</b>	-	-	-	
			Box of 72	<b>301-1630</b>	<b>55.00</b>	<b>49.50</b>	<b>46.75</b>	<b>41.25</b>	
		3mm	Box of 72	<b>313-1630</b>	<b>55.00</b>	<b>49.50</b>	<b>46.75</b>	<b>41.25</b>	
W164	80	1/8"	Pkg. of 12	<b>309-1640</b>	<b>12.00</b>	-	-	-	
			Box of 72	<b>301-1640</b>	<b>59.00</b>	<b>53.10</b>	<b>50.15</b>	<b>44.25</b>	
W165	80	1/8"	Pkg. of 12	<b>309-1650</b>	<b>11.00</b>	-	-	-	
			Box of 72	<b>301-1650</b>	<b>51.00</b>	<b>45.90</b>	<b>43.35</b>	<b>38.25</b>	
W168	80	1/8"	Pkg. of 12	<b>309-1680</b>	<b>11.00</b>	-	-	-	
			Box of 72	<b>301-1680</b>	<b>55.00</b>	<b>49.50</b>	<b>46.75</b>	<b>41.25</b>	
W169	60	1/8"	Pkg. of 12	<b>309-1690</b>	<b>11.00</b>	-	-	-	
			Box of 72	<b>301-1690</b>	<b>55.00</b>	<b>49.50</b>	<b>46.75</b>	<b>41.25</b>	
		3mm	Box of 72	<b>313-1690</b>	<b>55.00</b>	<b>49.50</b>	<b>46.75</b>	<b>41.25</b>	
W170	60	1/8"	Pkg. of 12	<b>309-1700</b>	<b>11.00</b>	-	-	-	
			Box of 72	<b>301-1700</b>	<b>55.00</b>	<b>49.50</b>	<b>46.75</b>	<b>41.25</b>	
W171	60	1/8"	Pkg. of 12	<b>309-1710</b>	<b>12.00</b>	-	-	-	
			Box of 72	<b>301-1710</b>	<b>59.00</b>	<b>53.10</b>	<b>50.15</b>	<b>44.25</b>	
W174	60	1/8"	Pkg. of 12	<b>309-1740</b>	<b>11.00</b>	-	-	-	
			Box of 72	<b>301-1740</b>	<b>55.00</b>	<b>49.50</b>	<b>46.75</b>	<b>41.25</b>	
W175	60	1/8"	Pkg. of 12	<b>309-1750</b>	<b>11.00</b>	-	-	-	
			Box of 72	<b>301-1750</b>	<b>55.00</b>	<b>49.50</b>	<b>46.75</b>	<b>41.25</b>	
W176	60	1/8"	Pkg. of 12	<b>309-1760</b>	<b>11.00</b>	-	-	-	
			Box of 72	<b>301-1760</b>	<b>55.00</b>	<b>49.50</b>	<b>46.75</b>	<b>41.25</b>	
		3mm	Box of 72	<b>313-1760</b>	<b>55.00</b>	<b>49.50</b>	<b>46.75</b>	<b>41.25</b>	
W178	60	1/8"	Pkg. of 12	<b>309-1780</b>	<b>14.00</b>	-	-	-	
			Box of 72	<b>301-1780</b>	<b>65.00</b>	<b>58.50</b>	<b>55.25</b>	<b>48.75</b>	
W181	80	1/8"	Pkg. of 12	<b>309-1810</b>	<b>11.00</b>	-	-	-	
			Box of 36	<b>301-1810</b>	<b>26.00</b>	<b>23.40</b>	<b>22.10</b>	<b>19.50</b>	
W182	80	1/8"	Pkg. of 12	<b>309-1820</b>	<b>11.00</b>	-	-	-	
			Box of 36	<b>301-1820</b>	<b>26.00</b>	<b>23.40</b>	<b>22.10</b>	<b>19.50</b>	
		3mm	Box of 36	<b>313-1820</b>	<b>26.00</b>	<b>23.40</b>	<b>22.10</b>	<b>19.50</b>	
W183	80	1/8"	Pkg. of 12	<b>309-1830</b>	<b>11.00</b>	-	-	-	
			Box of 36	<b>301-1830</b>	<b>26.00</b>	<b>23.40</b>	<b>22.10</b>	<b>19.50</b>	
W184	80	1/8"	Pkg. of 12	<b>309-1840</b>	<b>11.00</b>	-	-	-	
			Box of 36	<b>301-1840</b>	<b>27.00</b>	<b>24.30</b>	<b>22.95</b>	<b>20.25</b>	
		3mm	Box of 36	<b>313-1840</b>	<b>27.00</b>	<b>24.30</b>	<b>22.95</b>	<b>20.25</b>	

**Gesswein® Red Mounted Stones, cont'd**

Style	Grit	Shank	Qty.	Item#	PKG./BOX Prices			
					1	2-3	4-9	10+
W185	60	1/8"	Pkg. of 12	<b>309-1850</b>	<b>\$11.00</b>	—	—	—
			Box of 36	<b>301-1850</b>	<b>27.00</b>	<b>\$24.30</b>	<b>\$22.95</b>	<b>\$20.25</b>
			Box of 36	<b>313-1850</b>	<b>27.00</b>	<b>24.30</b>	<b>22.95</b>	<b>20.25</b>
W186	60	1/8"	Pkg. of 12	<b>309-1860</b>	<b>12.00</b>	—	—	—
			Box of 36	<b>301-1860</b>	<b>29.00</b>	<b>26.10</b>	<b>24.65</b>	<b>21.75</b>
W187	60	1/8"	Pkg. of 12	<b>309-1870</b>	<b>14.00</b>	—	—	—
			Box of 36	<b>301-1870</b>	<b>33.00</b>	<b>29.70</b>	<b>28.05</b>	<b>24.75</b>
W190	80	1/8"	Pkg. of 12	<b>309-1900</b>	<b>11.00</b>	—	—	—
			Box of 36	<b>301-1900</b>	<b>27.00</b>	<b>24.30</b>	<b>22.95</b>	<b>20.25</b>
W200	60	1/8"	Box of 12	<b>300-2000</b>	<b>11.00</b>	<b>9.90</b>	<b>9.35</b>	<b>8.25</b>
W201	60	1/8"	Box of 12	<b>300-2010</b>	<b>11.00</b>	<b>9.90</b>	<b>9.35</b>	<b>8.25</b>
W202	60	1/8"	Box of 12	<b>300-2020</b>	<b>13.00</b>	<b>11.70</b>	<b>11.05</b>	<b>9.75</b>
W204	60	1/8"	Box of 12	<b>300-2040</b>	<b>15.00</b>	<b>13.50</b>	<b>12.75</b>	<b>11.25</b>
W210	80	1/8"	Box of 12	<b>300-2100</b>	<b>13.00</b>	<b>11.70</b>	<b>11.05</b>	<b>9.75</b>
W211	80	1/8"	Box of 12	<b>300-2110</b>	<b>13.00</b>	<b>11.70</b>	<b>11.05</b>	<b>9.75</b>
W215	60	1/8"	Box of 12	<b>300-2150</b>	<b>13.00</b>	<b>11.70</b>	<b>11.05</b>	<b>9.75</b>
W216	60	1/8"	Box of 12	<b>300-2160</b>	<b>13.00</b>	<b>11.70</b>	<b>11.05</b>	<b>9.75</b>

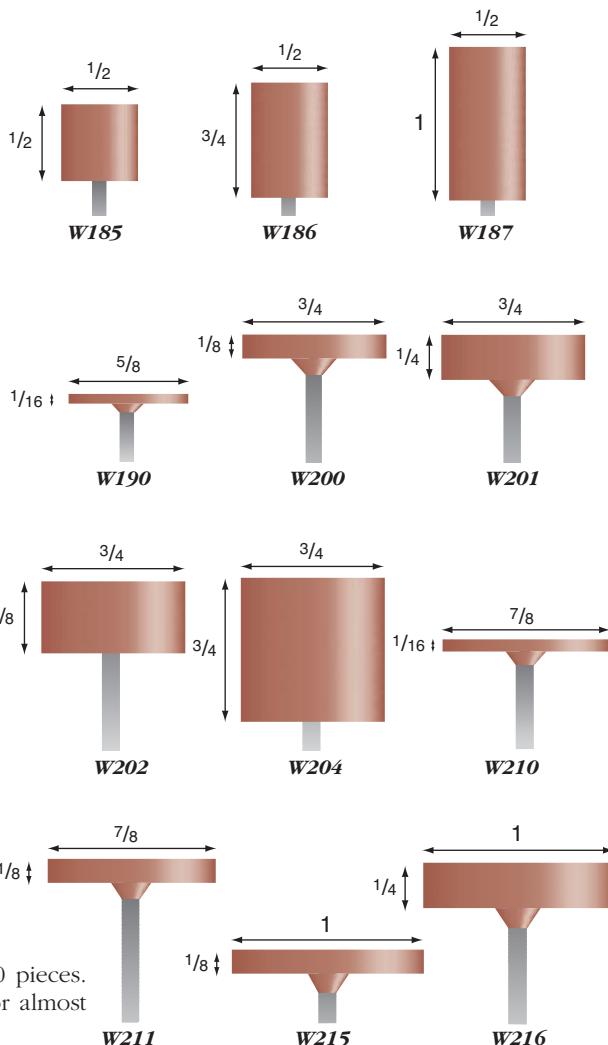

**A, B Gesswein® Red Mounted Stone Sets – 1/8" Shank**

Gesswein Red Mounted Stones are available in money-saving sets of 48 and 100 pieces. These assortments are made from our most popular shapes and offer a stone for almost every application. These sets offer big savings from the one-piece prices.

The 100-Piece Set includes ten each of our ten most popular shapes, conveniently packaged in a box to hold all 100 stones. Ten each of the following shapes: B44, B52, B96, B123, W144, W152, W162, W170, W175, W200.

The 48-Piece Set includes six each of eight popular shapes, conveniently packaged in a box to hold all 48 stones. Six each of the following shapes: B44, B52, B123, W144, W152, W162, W176, W200.

Description	Item#	Each
<b>A. 100-Piece Red Mounted Stone Set</b>	<b>310-3000</b>	<b>\$95.00</b>
<b>B. 48-Piece Red Mounted Stone Set</b>	<b>310-3010</b>	<b>46.00</b>



**C Rotating Bur Holders – Choose from three styles.**

Rotating Bur and Tool Holder accepts up to 112 burs or tools. Features ball bearings for smooth action. Includes 92 holes for tools with 3/32" or 1/8" shanks, 13 holes for tools with 1/4" shanks, 7 holes for 1/16" to 5/32" drill bits and 2 3/4" dia. x 3"H center cup for hand tools such as files, screwdrivers and more. Measures 7" dia. x 4"H.

Rotating Bur Holders accept up to 126 burs or tools. Universal has 45 holes for tools with 1/16" shanks, 69 two-step holes for tools with 3/32" or 1/8" shanks and 12 holes for tools with 1/4" shanks. The other holds tools with 3/32" shanks only. Measure 7" dia. x 4"H.

Description	Item#	Each
<b>C. Rotating Bur and Tool Holder</b>	<b>850-0006</b>	<b>\$14.95</b>
Rotating Bur Holder, universal	<b>850-0004</b>	<b>14.95</b>
Rotating Bur Holder, 3/32" only	<b>850-0005</b>	<b>14.95</b>





**Light Blue Mounted Stones**

These mounted stones incorporate a unique Sol Gel ceramic abrasive (3M Cubitron grain). The Sol Gel abrasive, produced by Sol Gel processing, is both hard and tough. It provides exceptional durability and cut rates in grinding mild, high-carbon and stainless steel as well as many nonferrous alloys. Under normal use, cut rate and wheel life are two to three times that of Red and Blue Mounted Stones. Particularly suited for precision grinding. Form and radius holding are greatly increased due to Sol Gel's durability. Light Blue Mounted Stones are extremely tough in all grades, chemically pure and of uniform quality. All are 120 grit. Can be dressed with our Tru-Stone #380-1030 (see p. 46). Before using any abrasive product, follow all safe operating guidelines with respect to eye protection, hand protection, hearing protection and respiratory protection (see p. 304 for details). Also read the Material Safety Data Sheet (MSDS) to be aware of any inherent hazards or cautions.

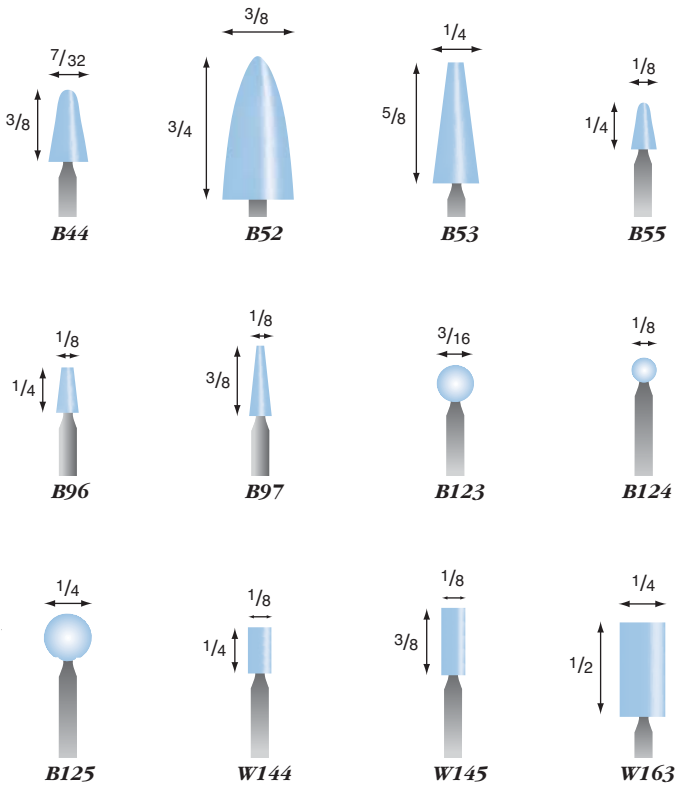

Style	Grit	Shank	Item#	EACH Prices	
				1-11	12+
B44	120	1/8" 3mm	<b>312-0440</b>	<b>\$3.00</b>	<b>\$2.50</b>
			<b>312-3019</b>	<b>3.00</b>	<b>2.50</b>
B52	120	1/8" 3mm	<b>312-0520</b>	<b>3.00</b>	<b>2.50</b>
			<b>312-3020</b>	<b>3.00</b>	<b>2.50</b>
B53	120	1/8" 3mm	<b>312-0530</b>	<b>3.00</b>	<b>2.50</b>
			<b>312-3021</b>	<b>3.00</b>	<b>2.50</b>
B55	120	1/8" 3mm	<b>312-0550</b>	<b>2.00</b>	<b>1.67</b>
			<b>312-3022</b>	<b>2.00</b>	<b>1.67</b>
B96	120	1/8" 3mm	<b>312-0960</b>	<b>2.00</b>	<b>1.67</b>
			<b>312-3023</b>	<b>2.00</b>	<b>1.67</b>
B97	120	1/8" 3mm	<b>312-0970</b>	<b>3.00</b>	<b>2.50</b>
			<b>312-3024</b>	<b>3.00</b>	<b>2.50</b>
B123	120	1/8" 3mm	<b>312-1230</b>	<b>2.00</b>	<b>1.67</b>
			<b>312-3025</b>	<b>2.00</b>	<b>1.67</b>
B124	120	1/8" 3mm	<b>312-1240</b>	<b>2.00</b>	<b>1.67</b>
			<b>312-3026</b>	<b>2.00</b>	<b>1.67</b>
B125	120	1/8" 3mm	<b>312-1250</b>	<b>3.00</b>	<b>2.50</b>
			<b>312-3027</b>	<b>3.00</b>	<b>2.50</b>
W144	120	1/8" 3mm	<b>312-1440</b>	<b>2.00</b>	<b>1.67</b>
			<b>312-3028</b>	<b>2.00</b>	<b>1.67</b>
W145	120	1/8" 3mm	<b>312-1450</b>	<b>2.00</b>	<b>1.67</b>
			<b>312-3029</b>	<b>2.00</b>	<b>1.67</b>
W163	120	1/8" 3mm	<b>312-1630</b>	<b>2.00</b>	<b>1.67</b>
			<b>312-3030</b>	<b>2.00</b>	<b>1.67</b>



**A**

**A Light Blue Mounted Stone Set**

Buy the 12-piece assortment of these stones and have one for every application. Includes one each of above shapes. Conveniently packaged in a durable plastic box. Also available on 3mm shanks.

Description	Item#	Each
Light Blue Mounted Stone Set, 1/8"	<b>312-3000</b>	<b>\$25.00</b>
Light Blue Mounted Stone Set, 3mm	<b>312-3031</b>	<b>25.00</b>



**B**

**B Handy Block – For 1/8" or 3/32" Shanks**

An 88-hole block of cured hardwood for organizing burs, needle files, brushes and more. All holes are 1/8" in diameter to accommodate either 1/8" or 3/32" shanks. Block is slanted so user can see all tools at a glance. Stay-put rubber pads keep block from sliding. Weighs 1 lb., 2 oz. Measures 4 1/2" x 6".

Description	Item#	Each
Handy Block	<b>814-1215</b>	<b>\$14.95</b>



**Gesswein® Blue Mounted Points – 3/32" Shank**

Hard blue aluminum oxide stones with cobalt added to provide lubrication while grinding. Hold their shapes, cut well and leave a smooth surface. Recommended for use on hardened steel. For recommended speeds, consult the American National Standard Institute for full information on vitrified mounted wheels. Mounted on 3/32" dia. x 1 1/2"L nickel-plated steel shanks. All are 120 grit. Can be dressed with our Tru-Stone #380-1030 (see p. 46). For safety requirements please see p. 304. Before using any abrasive product, follow all safe operating guidelines with respect to eye protection, hand protection, hearing protection and respiratory protection (see p. 304 for details). Also read the Material Safety Data Sheet (MSDS) to be aware of any inherent hazards or cautions.



Style	Grit	Shank	Qty.	Item#	Pkg./Box Price
1	120	3/32"	Pkg. of 12 Box of 72	<b>316-0010</b> <b>314-0010</b>	<b>\$14.00</b> <b>61.00</b>
2	120	3/32"	Pkg. of 12 Box of 72	<b>316-0020</b> <b>314-0020</b>	<b>14.00</b> <b>61.00</b>
3	120	3/32"	Pkg. of 12 Box of 72	<b>316-0030</b> <b>314-0030</b>	<b>14.00</b> <b>61.00</b>
6	120	3/32"	Pkg. of 12 Box of 72	<b>316-0060</b> <b>314-0060</b>	<b>14.00</b> <b>61.00</b>
7	120	3/32"	Pkg. of 12 Box of 72	<b>316-0070</b> <b>314-0070</b>	<b>14.00</b> <b>61.00</b>
9	120	3/32"	Pkg. of 12 Box of 72	<b>316-0090</b> <b>314-0090</b>	<b>14.00</b> <b>61.00</b>
10	120	3/32"	Pkg. of 12 Box of 72	<b>316-0100</b> <b>314-0100</b>	<b>14.00</b> <b>61.00</b>
12	120	3/32"	Pkg. of 12 Box of 72	<b>316-0120</b> <b>314-0120</b>	<b>14.00</b> <b>61.00</b>
13	120	3/32"	Pkg. of 12 Box of 72	<b>316-0130</b> <b>314-0130</b>	<b>14.00</b> <b>61.00</b>
14	120	3/32"	Pkg. of 12 Box of 72	<b>316-0140</b> <b>314-0140</b>	<b>14.00</b> <b>61.00</b>
15	120	3/32"	Pkg. of 12 Box of 72	<b>316-0150</b> <b>314-0150</b>	<b>14.00</b> <b>61.00</b>
16	120	3/32"	Pkg. of 12 Box of 72	<b>316-0160</b> <b>314-0160</b>	<b>14.00</b> <b>61.00</b>
20	120	3/32"	Pkg. of 12 Box of 72	<b>316-0200</b> <b>314-0200</b>	<b>14.00</b> <b>61.00</b>
21	120	3/32"	Pkg. of 12 Box of 72	<b>316-0210</b> <b>314-0210</b>	<b>17.00</b> <b>74.00</b>
22	120	3/32"	Pkg. of 12 Box of 72	<b>316-0220</b> <b>314-0220</b>	<b>17.00</b> <b>74.00</b>
23	120	3/32"	Pkg. of 12 Box of 72	<b>316-0230</b> <b>314-0230</b>	<b>17.00</b> <b>74.00</b>
24	120	3/32"	Pkg. of 12 Box of 72	<b>316-0240</b> <b>314-0240</b>	<b>17.00</b> <b>74.00</b>
32	120	3/32"	Pkg. of 12 Box of 72	<b>316-0320</b> <b>314-0320</b>	<b>17.00</b> <b>74.00</b>
34	120	3/32"	Pkg. of 12 Box of 72	<b>316-0340</b> <b>314-0340</b>	<b>17.00</b> <b>74.00</b>

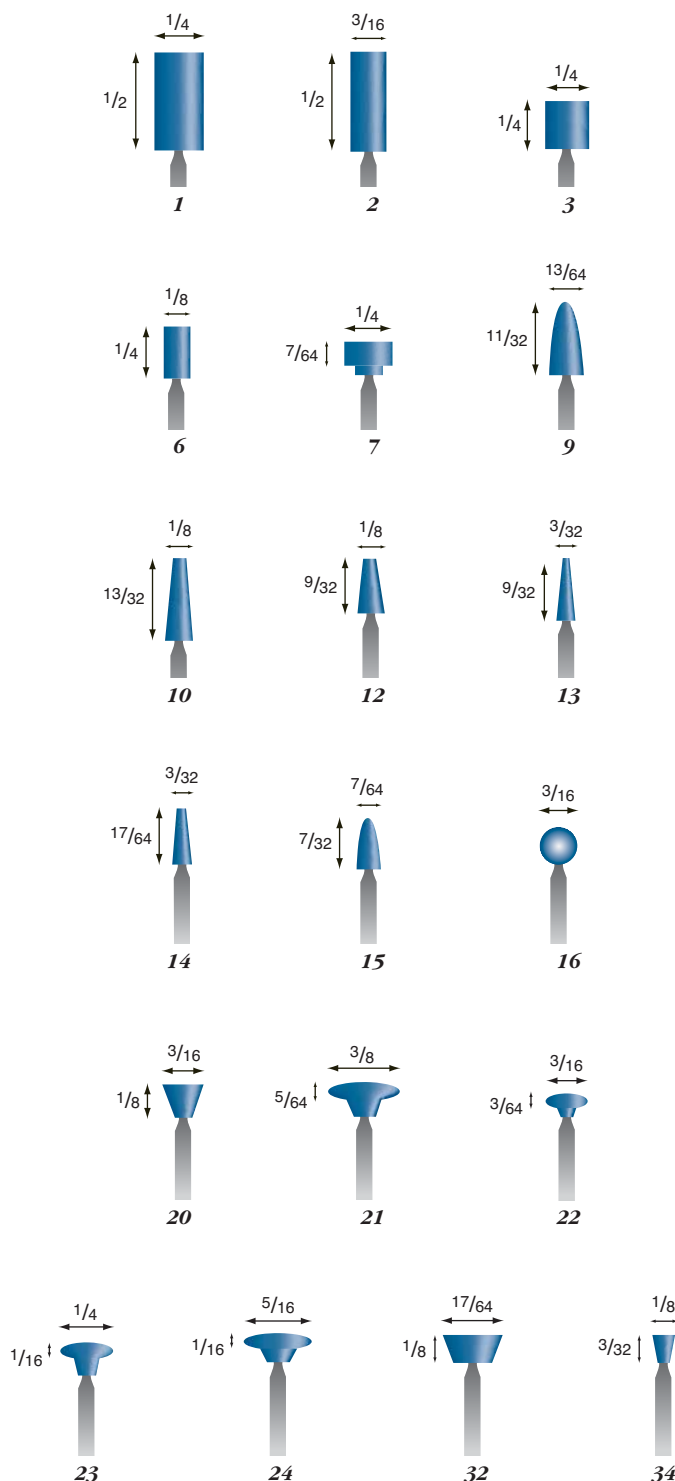



**Gesswein® Red Mounted Points – 3/32" Shank**

Very fast-cutting, nonloading aluminum oxide points, easily identified by their red-dish-brown color. For fast grinding of medium and hard materials. Ideal for internal grinding of tools, dies and gauges. For recommended speeds, consult the American National Standard Institute for full information on vitrified mounted wheels. Mounted on 3/32" dia. x 1 1/2" L nickel-plated steel shanks. Range from 80 to 150 grit. Can be dressed with our Tru-Stone #380-1030 (see p. 46). Before using any abrasive product, follow all safe operating guidelines with respect to eye protection, hand protection, hearing protection and respiratory protection (see p. 304 for details). Also read the Material Safety Data Sheet (MSDS) to be aware of any inherent hazards or cautions.

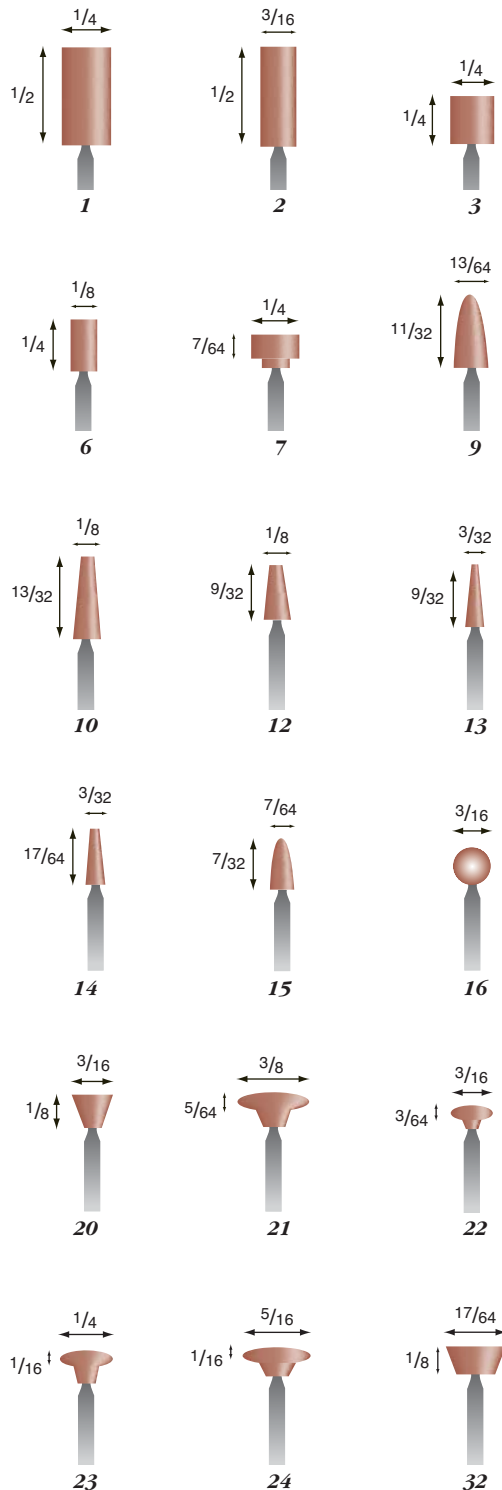

Style	Grit	Shank	Qty.	Item#	Pkg./Box Price
1	80	3/32"	Pkg. of 12	<b>321-0010</b>	<b>\$13.00</b>
			Box of 72	<b>319-0010</b>	<b>56.00</b>
2	80	3/32"	Pkg. of 12	<b>321-0020</b>	<b>13.00</b>
			Box of 72	<b>319-0020</b>	<b>56.00</b>
3	80	3/32"	Pkg. of 12	<b>321-0030</b>	<b>13.00</b>
			Box of 72	<b>319-0030</b>	<b>56.00</b>
6	120	3/32"	Pkg. of 12	<b>321-0060</b>	<b>13.00</b>
			Box of 72	<b>319-0060</b>	<b>56.00</b>
7	120	3/32"	Pkg. of 12	<b>321-0070</b>	<b>13.00</b>
			Box of 72	<b>319-0070</b>	<b>56.00</b>
9	100	3/32"	Pkg. of 12	<b>321-0090</b>	<b>13.00</b>
			Box of 72	<b>319-0090</b>	<b>56.00</b>
10	100	3/32"	Pkg. of 12	<b>321-0100</b>	<b>13.00</b>
			Box of 72	<b>319-0100</b>	<b>56.00</b>
12	120	3/32"	Pkg. of 12	<b>321-0120</b>	<b>13.00</b>
			Box of 72	<b>319-0120</b>	<b>56.00</b>
13	120	3/32"	Pkg. of 12	<b>321-0130</b>	<b>13.00</b>
			Box of 72	<b>319-0130</b>	<b>56.00</b>
14	120	3/32"	Pkg. of 12	<b>321-0140</b>	<b>13.00</b>
			Box of 72	<b>319-0140</b>	<b>56.00</b>
15	120	3/32"	Pkg. of 12	<b>321-0150</b>	<b>13.00</b>
			Box of 72	<b>319-0150</b>	<b>56.00</b>
16	100	3/32"	Pkg. of 12	<b>321-0160</b>	<b>13.00</b>
			Box of 72	<b>319-0160</b>	<b>56.00</b>
20	150	3/32"	Pkg. of 12	<b>321-0200</b>	<b>13.00</b>
			Box of 72	<b>319-0200</b>	<b>56.00</b>
21	120	3/32"	Pkg. of 12	<b>321-0210</b>	<b>13.00</b>
			Box of 72	<b>319-0210</b>	<b>56.00</b>
22	100	3/32"	Pkg. of 12	<b>321-0220</b>	<b>13.00</b>
			Box of 72	<b>319-0220</b>	<b>56.00</b>
23	120	3/32"	Pkg. of 12	<b>321-0230</b>	<b>13.00</b>
			Box of 72	<b>319-0230</b>	<b>56.00</b>
24	120	3/32"	Pkg. of 12	<b>321-0240</b>	<b>13.00</b>
			Box of 72	<b>319-0240</b>	<b>56.00</b>
32	150	3/32"	Pkg. of 12	<b>321-0320</b>	<b>13.00</b>
			Box of 72	<b>319-0320</b>	<b>56.00</b>

**White Polishing Points – 3/32" Shank**

Made of extremely fine white aluminum oxide, these points can be used on glass, porcelain, metal or stone. Produce a high finish. For recommended speeds, consult the American National Standard Institute for full information on vitrified mounted wheels. Mounted on 3/32" dia. x 1 1/2"L nickel-plated steel shanks. All are 400 grit. Can be dressed with our Tru-Stone #380-1030 (see p. 46). Before using any abrasive product, follow all safe operating guidelines with respect to eye protection, hand protection, hearing protection and respiratory protection (see p. 304 for details). Also read the Material Safety Data Sheet (MSDS) to be aware of any inherent hazards or cautions.



Style	Grit	Shank	Qty.	Item#	Pkg./Box Price
3P	400	3/32"	Pkg. of 12	<b>326-0030</b>	<b>\$20.00</b>
			Box of 72	<b>324-0030</b>	<b>87.00</b>
12P	400	3/32"	Pkg. of 12	<b>326-0120</b>	<b>20.00</b>
			Box of 72	<b>324-0120</b>	<b>87.00</b>
14P	400	3/32"	Pkg. of 12	<b>326-0140</b>	<b>20.00</b>
			Box of 72	<b>324-0140</b>	<b>87.00</b>
18P	400	3/32"	Pkg. of 12	<b>326-0180</b>	<b>20.00</b>
			Box of 72	<b>324-0180</b>	<b>87.00</b>
19P	400	3/32"	Pkg. of 12	<b>326-0190</b>	<b>20.00</b>
			Box of 72	<b>324-0190</b>	<b>87.00</b>
22P	400	3/32"	Pkg. of 12	<b>326-0220</b>	<b>20.00</b>
			Box of 72	<b>324-0220</b>	<b>87.00</b>
26P	400	3/32"	Pkg. of 12	<b>326-0260</b>	<b>20.00</b>
			Box of 72	<b>324-0260</b>	<b>87.00</b>
32P	400	3/32"	Pkg. of 12	<b>326-0320</b>	<b>20.00</b>
			Box of 72	<b>324-0320</b>	<b>87.00</b>
34P	400	3/32"	Pkg. of 12	<b>326-0340</b>	<b>20.00</b>
			Box of 72	<b>324-0340</b>	<b>87.00</b>
41P	400	3/32"	Pkg. of 12	<b>326-0410</b>	<b>20.00</b>
			Box of 72	<b>324-0410</b>	<b>87.00</b>
44P	400	3/32"	Pkg. of 12	<b>326-0440</b>	<b>20.00</b>
			Box of 72	<b>324-0440</b>	<b>87.00</b>
46P	400	3/32"	Pkg. of 12	<b>326-0460</b>	<b>20.00</b>
			Box of 72	<b>324-0460</b>	<b>87.00</b>

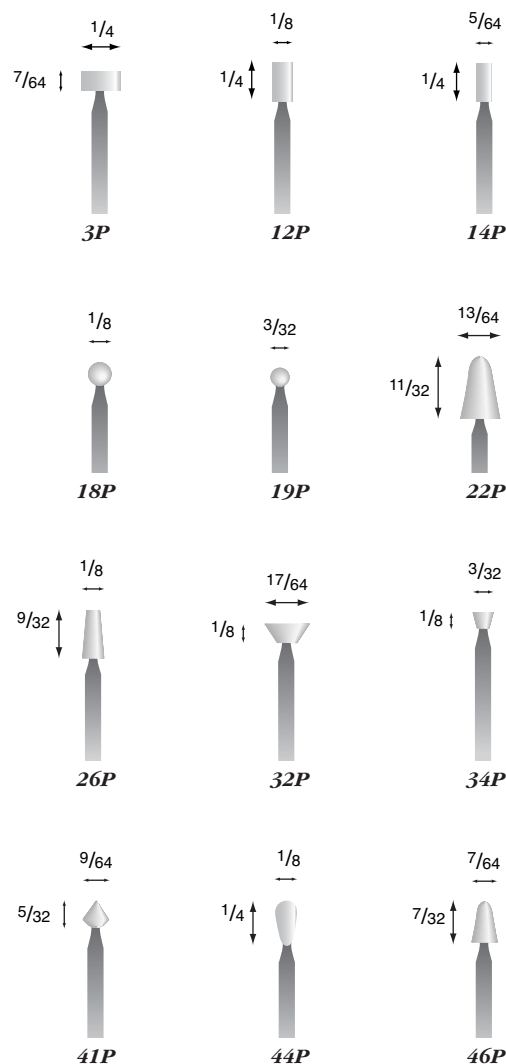

**A Plastic Bur Holder – For 3/32" Shanks**

Accepts up to 100 burs or tools with 3/32" shanks. Supplied with tilt stand. Measures 5" x 3".

Description	Item#	EACH Prices	
		1-2	3+
Plastic Bur Holder	<b>840-0007</b>	<b>\$5.45</b>	<b>\$4.36</b>

**B Interlocking Bur Block – For 3/32" Shanks**

Accepts up to 40 burs or tools with 3/32" shanks. Features interlocking design for limitless storage capacity. Measures 4 1/4" x 3 1/8".

Description	Item#	EACH Prices	
		1-2	3+
Interlocking Bur Block	<b>124-4710</b>	<b>\$2.65</b>	<b>\$2.39</b>

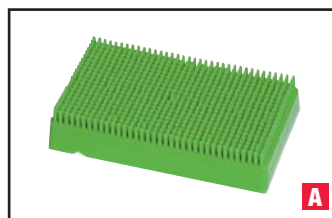



**Busch® Pink Polishing Points – 3/32" Shank**

Made of genuine corundum, these points are recommended for use on harder metals. For recommended speeds, consult the American National Standard Institute for full information on vitrified mounted wheels. Mounted on 3/32" dia. x 1 1/2"L nickel-plated steel shanks. All are medium grit. Can be dressed with our Tru-Stone #380-1030 (see below). Before using any abrasive product, follow all safe operating guidelines with respect to eye protection, hand protection, hearing protection and respiratory protection (see p. 304 for details). Also read the Material Safety Data Sheet (MSDS) to be aware of any inherent hazards or cautions.

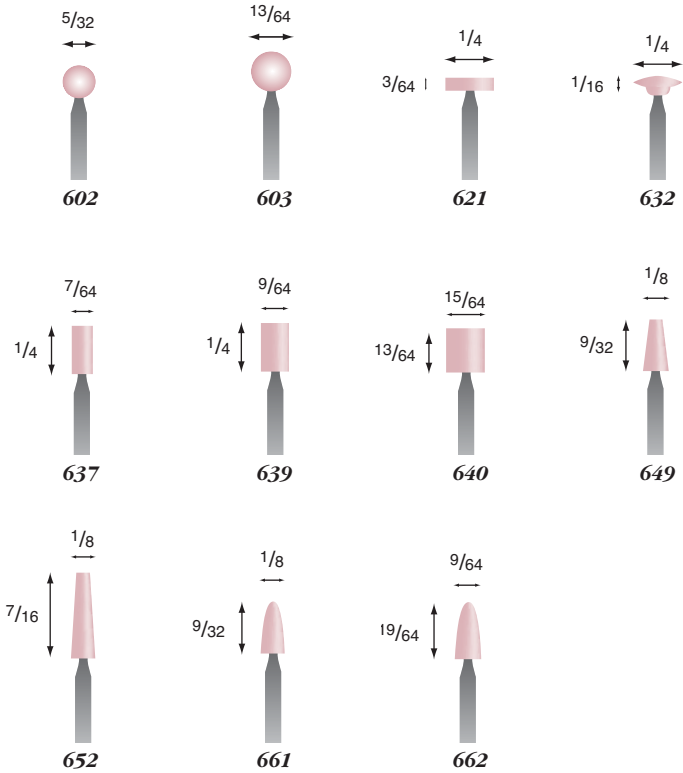

Style	Grit	Item#	EACH Prices		
			1-5	6-71	72+
602	Med.	<b>330-1325</b>	<b>\$2.50</b>	<b>\$2.13</b>	<b>\$2.00</b>
603	Med.	<b>330-1330</b>	<b>2.50</b>	<b>2.13</b>	<b>2.00</b>
621	Med.	<b>330-1340</b>	<b>2.50</b>	<b>2.13</b>	<b>2.00</b>
632	Med.	<b>330-1345</b>	<b>2.50</b>	<b>2.13</b>	<b>2.00</b>
637	Med.	<b>330-1350</b>	<b>2.50</b>	<b>2.13</b>	<b>2.00</b>
639	Med.	<b>330-1355</b>	<b>2.50</b>	<b>2.13</b>	<b>2.00</b>
640	Med.	<b>330-1360</b>	<b>2.38</b>	<b>2.02</b>	<b>1.90</b>
649	Med.	<b>330-1365</b>	<b>2.38</b>	<b>2.02</b>	<b>1.90</b>
652	Med.	<b>330-1370</b>	<b>2.38</b>	<b>2.02</b>	<b>1.90</b>
661	Med.	<b>330-1375</b>	<b>2.38</b>	<b>2.02</b>	<b>1.90</b>
662	Med.	<b>330-1380</b>	<b>2.38</b>	<b>2.02</b>	<b>1.90</b>



**A**

**A Rotating Bur Holder – 3/32" Shank**

Handy tiered holder rotates to keep tools within easy reach. Holds 150 burs or tools. All holes are 3/32" in diameter to accommodate 3/32" shanks. Weighs 12 oz. Measures 4"H x 6" dia. at base.

Description	Item#	Each
Rotating Bur Holder	<b>124-4720</b>	<b>\$11.90</b>



**B**

**B Tru-Stone**

**For dressing and shaping mounted stones and abrasive wheels.**

A very hard and coarse grit silicon carbide stone with four different sized half-round grooves measuring 1/16", 1/8", 3/16" and 1/4" on one side. Quickly reshapes and resurfaces abrasive stones to like-new condition. Measures 3 1/2"L x 1 3/8"W x 9/16"H.

Description	Item#	EACH Prices	
		1-9	10+
Tru-Stone	<b>380-1030</b>	<b>\$5.60</b>	<b>\$4.48</b>



**A Dressing Stone – Medium grit**

A very hard, 150 grit stone in a convenient shape for dressing grinding wheels, G-Flex and GMX wheels. Measures 2½"L x 1½"W x ½"H.

Description	Grit	Item#	Each
Medium Dressing Stone	150	<b>380-1020</b>	<b>\$4.05</b>



**A**

**B Dressing Stone – Coarse grit**

A very hard, 20 grit stone that will quickly smooth out and take off irregular edges from almost any grinding wheel or MX Lap. Also excellent for shaping Bear-Tex Wheels (see p. 60). Measures 6" x 1" square.

Description	Grit	Item#	Each
Coarse Dressing Stone	20	<b>380-1010</b>	<b>\$9.80</b>



**B**

**C Type VS Dressing Stones for Diamond Wheels**

Made of premium quality white aluminum oxide. Very soft stones used for cleaning diamond wheels. Stones are evenly bonded and have precise grits.

Grit	Dimensions	Item#	EACH Prices			
			1-49	50-249	250-499	500+
80	6" x ½" x ½"	<b>381-0005</b>	<b>\$2.36</b>	<b>\$2.01</b>	<b>\$1.68</b>	<b>\$1.46</b>
120	6" x ½" x ½"	<b>381-0105</b>	<b>2.36</b>	<b>2.01</b>	<b>1.68</b>	<b>1.46</b>
150	6" x ½" x ½"	<b>381-0115</b>	<b>2.36</b>	<b>2.01</b>	<b>1.68</b>	<b>1.46</b>
220	6" x ½" x ½"	<b>381-0205</b>	<b>2.36</b>	<b>2.01</b>	<b>1.68</b>	<b>1.46</b>
320	6" x ½" x ½"	<b>381-0305</b>	<b>3.26</b>	<b>2.77</b>	<b>2.31</b>	<b>2.02</b>
80	6" x ¾" x ¾"	<b>381-1007</b>	<b>3.83</b>	<b>3.26</b>	<b>2.72</b>	<b>2.37</b>
120	6" x ¾" x ¾"	<b>381-1107</b>	<b>3.83</b>	<b>3.26</b>	<b>2.72</b>	<b>2.37</b>
150	6" x ¾" x ¾"	<b>381-1117</b>	<b>3.83</b>	<b>3.26</b>	<b>2.72</b>	<b>2.37</b>
220	6" x ¾" x ¾"	<b>381-1207</b>	<b>3.83</b>	<b>3.26</b>	<b>2.72</b>	<b>2.37</b>
320	6" x ¾" x ¾"	<b>381-1307</b>	<b>6.25</b>	<b>5.31</b>	<b>4.44</b>	<b>3.88</b>



**C**

**D PBC Dressing Stones**

**Long-lasting stones made of sintered boron carbide.**

Gesswein's PBC Dressing Stones are used to quickly dress grinding wheels. They also leave a super-bright polish when used as a final step in sharpening of all types of gravers – even cobalt and carbide. Manufactured from boron carbide, which approaches diamond in hardness, these stones are made to last!

Description	Dimensions	Item#	Each
Small PBC Dressing Stone	3" x ½" x ¼"	<b>380-1040</b>	<b>\$33.75</b>



**D**

**E Norton® Norbide® Dressing Stick**

The Norbide Dressing Stick is used to economically dress, shape and true vitrified grinding wheels. It's also the choice for "roughing in" a shape prior to diamond truing precision grinding wheels. Measures 3"L x ½"W x ⅜"H.

Description	Item#	Each
Norbide Dressing Stick	<b>380-1035</b>	<b>\$54.50</b>



**E**



**A**

**A Norton® White Aluminum Oxide Grinding Wheels – For light grinding.**

For light grinding of all kinds. Particularly good on hard, heat-sensitive materials such as high-speed steel and cast-alloy tools. Hardness is rated from softest (H) to hardest (K).

Dia. x Thick x AH	Grit	Hardness	Item#	EACH Prices	
				1-9	10+
7" x 1/4" x 1 1/4"	60	J	<b>245-3080</b>	<b>\$22.55</b>	<b>\$13.53</b>
	80	J	<b>245-3085</b>	<b>22.55</b>	<b>13.53</b>
	100	J	<b>245-3090</b>	<b>22.55</b>	<b>13.53</b>
	120	K	<b>245-3095</b>	<b>22.55</b>	<b>13.53</b>
7" x 1/2" x 1 1/4"	150	K	<b>245-3100</b>	<b>39.40</b>	<b>23.64</b>
	46	I	<b>245-3110</b>	<b>28.05</b>	<b>16.83</b>
	60	I	<b>245-3115</b>	<b>28.05</b>	<b>16.83</b>
	60	J	<b>245-3120</b>	<b>28.05</b>	<b>16.83</b>
8" x 1/2" x 1 1/4"	80	J	<b>245-3125</b>	<b>28.05</b>	<b>16.83</b>
	46	H	<b>245-3140</b>	<b>33.57</b>	<b>20.14</b>
	60	K	<b>245-3150</b>	<b>33.57</b>	<b>20.14</b>



**B**

**B Norton® Aluminum Oxide Grinding Wheels – For moderate to heavy grinding.**

For moderate to heavy grinding of tool steels, including tough alloys. Allow exceptionally fast, cool cutting. Hold form well and require minimum dressing.

Dia. x Thick x AH	Grit	Hardness	Item#	EACH Prices	
				1-9	10+
7" x 1/4" x 1 1/4"	80	I	<b>245-3195</b>	<b>\$29.25</b>	<b>\$23.40</b>
7" x 1/2" x 1 1/4"	46	K	<b>245-3200</b>	<b>41.05</b>	<b>32.84</b>
	60	I	<b>245-3205</b>	<b>41.05</b>	<b>32.84</b>
	80	I	<b>245-3215</b>	<b>41.05</b>	<b>32.84</b>



**C**

**C Norton® 5SG Blue Ceramic Grinding Wheel – For precision grinding.**

For precision grinding of difficult-to-grind hardened tool steel and exotic alloys. Hard, sharp ceramic abrasive wears slow, lasts long and grinds fast. During grinding, the grain resharpen itself, continuously exposing fresh cutting points. Wheel contains 50% Sol Gel and 50% aluminum oxide in a vitrified bond.

Dia. x Thick x AH	Grit	Hardness	Item#	EACH Prices	
				1-9	10+
7" x 1/2" x 1 1/4"	60	J	<b>245-3272</b>	<b>\$76.10</b>	<b>\$60.88</b>



**D**

**D GP Plus™ and LDW Convolute Wheels**

Ideal for a variety of deburring, blending, finishing and polishing applications. Consist of nonwoven material embedded with fine silicon carbide and wound around a reinforced center core (like a rolled up sleeping bag). Produce a unique cushion effect for controlled, fast cutting and consistent, uniform finishing. Maintain integrity under abusive conditions. Easy to shape and dress. Run smoothly and quietly. Require no compounds. Can be used with water or water-soluble oil if desired. Choose GP Plus (high-density wheels) for the toughest jobs and LDW (low-density wheels) for finer, more delicate work. Combine with flanges (see below) and appropriate arbor (see p. 136) to mount on your polishing motor.

Dia. x Thick x AH	Type	Grade*	Item#	Each
6" x 1/2" x 1"	GP Plus	9SF	<b>845-0069</b>	<b>\$37.95</b>
	GP Plus	8SF	<b>845-0067</b>	<b>39.95</b>
	LDW	7SF	<b>845-0065</b>	<b>39.95</b>
6" x 1" x 1"	GP Plus	9SF	<b>845-0070</b>	<b>52.95</b>
	GP Plus	8SF	<b>845-0068</b>	<b>55.95</b>
	LDW	7SF	<b>845-0066</b>	<b>55.95</b>

Description	Item#	Pkg. of 2
Flanges for converting 1"AH to 1/2"AH	<b>277-0089</b>	<b>\$3.95</b>
Flanges for converting 1"AH to 3/8"AH	<b>277-0091</b>	<b>3.95</b>

*\*Wheels are graded from most to least dense (9SF to 7SF), but scales for GP Plus and LDW are dissimilar, so there is a much larger difference between 7SF and 8SF than 8SF and 9SF.*

**A - F AirFlex Silicone Wheels – For cooler grinding and polishing.**

Tiny pockets of air are uniformly interspersed throughout our AirFlex wheels, so they grind and polish quickly without overheating the workpiece. The work stays cooler, so you can work longer without burning your fingers. AirFlex Blue (coarse) quickly removes rough surfaces, burs and tool marks. AirFlex Gray (medium) removes medium-grit file marks and leaves a matte finish. AirFlex Brown (fine) removes light scratches and leaves a bright surface.

AirFlex wheels work equally well on all precious alloys, including stainless steel and titanium. Flexible AirFlex follows contours and leaves a smooth, uniform finish. Made of silicon carbide abrasive in a silicone rubber bond. AirFlex wheels are available in two sizes. The 7/8" square edge wheels are 1/8" thick with 1/16" arbor hole. See p. 131 for mandrels. Max. operating speed: 10,000rpm. The 4" wheels are 1/32" thick with 1/4" arbor hole. Max. operating speed: 3,000rpm.

AirFlex	Diameter	Grit	Pkg. of 10		Box of 100	
			Item#	Each	Item#	Each
<b>A.</b> Blue (coarse)	7/8"	80	<b>145-1106</b>	<b>\$5.40</b>	<b>145-1107</b>	<b>\$54.90</b>
<b>B.</b> Gray (medium)	7/8"	240	<b>145-1108</b>	<b>5.40</b>	<b>145-1109</b>	<b>54.90</b>
<b>C.</b> Brown (fine)	7/8"	800	<b>145-1104</b>	<b>5.40</b>	<b>145-1105</b>	<b>54.90</b>
AirFlex	Diameter	Grit	Item#		Each	
<b>D.</b> Blue (coarse)	4"	80	<b>145-1180</b>		<b>\$21.45</b>	
<b>E.</b> Gray (medium)	4"	240	<b>145-1181</b>		<b>21.45</b>	
<b>F.</b> Brown (fine)	4"	800	<b>145-1182</b>		<b>21.45</b>	

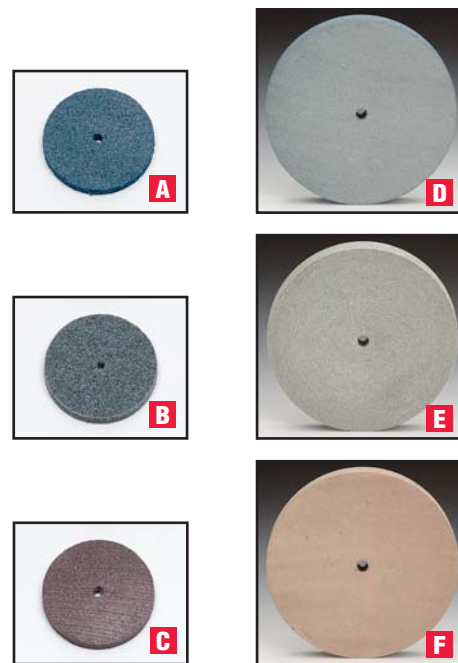

**G 3M™ XR Metalworking Wheel**

This molded, compressed unitized wheel provides fast cutting action, smooth finish and long life. Aluminum oxide, hard density, medium grade (120/220 grit). Max. operating speed: 3,600rpm. Mount on Tapered Spindle Adapter #145-1931 for use with your polishing motor.

Description	Dia. x Thick x AH	Grade	Item#	Each
XR Wheel	6" x 1" x 1"	Medium	<b>277-0290</b>	<b>\$73.85</b>
Adapter for 1"AH			<b>145-1931</b>	<b>5.25</b>



**H 3M™ Scotch-Brite™ Light Deburring Wheel**

A clean, safe and economical wheel for removing parting lines, firescale and oxidation. Produces a satin finish on copper, brass and stainless steel. Silicon carbide, fine grade. Max. operating speed: 6,000rpm. Mount on Tapered Spindle Adapter #145-1931 for use with your polishing motor.

Description	Dia. x Thick x AH	Grade	Item#	Each
Scotch-Brite Wheel	6" x 1" x 1"	Fine	<b>845-1089</b>	<b>\$54.95</b>
Adapter for 1"AH			<b>145-1931</b>	<b>5.25</b>



**I Rub-Out Stick and Holder**

For touch-ups and removal of light scratches on polished surfaces. Made of flexible rubber with silicon carbide abrasive. Holder gives support and gripping power. Stick can be exposed or withdrawn as desired and is easily dressed to the best shape for the job. Also removes rust, heat marks and stains while leaving a polished surface. Measures 6"L x 3/8" dia.

Description	Item#	SET Prices	
		1-4	5+
Stick and Holder, Fine Grit	<b>145-1300</b>	<b>\$15.50</b>	<b>\$13.95</b>
Stick and Holder, Extra-Fine Grit	<b>145-1302</b>	<b>15.50</b>	<b>13.95</b>
Refill Stick, Fine Grit	145-1306	6.75	6.08
Refill Stick, Extra-Fine Grit	145-1308	6.75	6.08



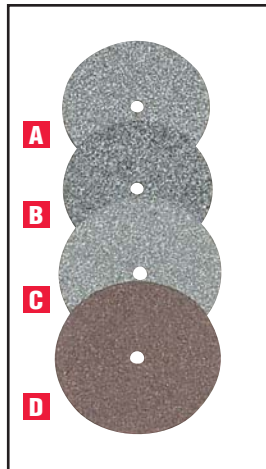

## A - D Cut-Off Discs

Both sides and edges of these thin discs can be used for slitting and finishing steel, brass, porcelain, and acrylics (except #845-1017, which has abrasive on one side only). All are resin-bonded, unmounted with 1/16" arbor hole. See p. 131 for mandrels.

Dia. x Thickness	Abrasive	Max. RPM	Item#	EACH Prices	
				10-90	100+
1 1/4" x .025"	Aluminum oxide	21,000	<b>845-1024*</b>	<b>\$.52</b>	<b>\$.34</b>
1 1/2" x .050"	Aluminum oxide	21,000	<b>845-1025*</b>	<b>.52</b>	<b>.34</b>

Dia. x Thickness	Abrasive	Max. RPM	Item#	Box of 100	
<b>A.</b> 7/8" x .023"	Silicon carbide	14,000	<b>845-1017**</b>	<b>\$8.50</b>	
<b>B.</b> 7/8" x .023"	Silicon carbide	14,000	<b>845-1020</b>	<b>8.10</b>	
<b>C.</b> 1" x .023"	Silicon carbide	14,000	<b>845-1021</b>	<b>8.10</b>	
<b>D.</b> 1" x .025"	Aluminum oxide	25,000	<b>845-1022</b>	<b>8.40</b>	

**\*10-piece minimum; please order in multiples of 10.**

**\*\*One side safe.**



## E Ultra-Thin Cut-Off Discs

These extremely thin silicon carbide discs (.009" thickness, 1/16" hole) cut quickly. Excellent for slots and grooves. See p. 131 for mandrels.

Dia. x Thickness	Abrasive	Max. RPM	Item#	BOX of 25		
				1-2	3-5	6+
7/8" x .009"	Silicon Carbide	14,000	<b>845-1050</b>	<b>\$8.95</b>	<b>\$8.50</b>	<b>\$8.06</b>

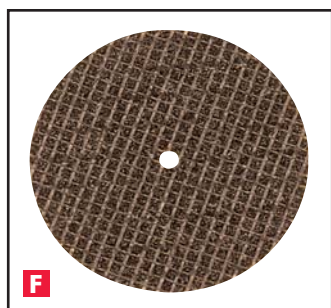

## F Nylon Cut-Off Discs

Combination of ceramic and zirconia alumina abrasives. These resin-bonded discs are made from long-lasting interwoven nylon fibers. Fast-cutting and economical. Measure 1 1/2" dia. x .035" thick with 1/16" arbor hole. See p. 131 for mandrels.

Dia. x Thickness	Grit	Max. RPM	Item#	EACH Prices	
				1-11	12+
1 1/2" x .035"	60	24,000	<b>845-1028</b>	<b>\$1.75</b>	<b>\$1.58</b>

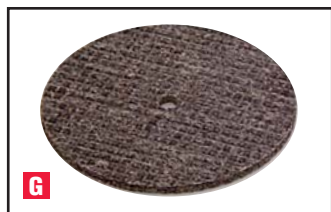

## G Fast Cut Discs

Thin and somewhat flexible for access into slots and grooves. Made of fast-cutting aluminum oxide, resin-bonded and cloth-reinforced. Discs have 1/8" arbor hole and cut on edge. See p. 131 for mandrels.

Dia. x Thickness	Grit	Max. RPM	Item#	EACH Prices	
				1-11	12+
<b>G.</b> 1 1/2" x .0625"	80	36,160	<b>845-3800</b>	<b>\$3.25</b>	<b>\$2.76</b>
1" x .040"	180	45,900	<b>845-3700</b>	<b>2.95</b>	<b>2.51</b>

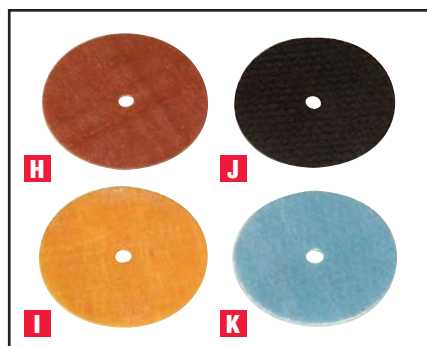

## H - K Super Ceramic Wheels

Wheel-shaped Super Ceramic Stones. Use for polishing or as a superior grade cut-off wheel. Available in four grits. See p. 131 for mandrels. Max. operating speed: 27,000rpm.

Dia. x Thick x AH Dimensions (mm)	Grit	Color	Item#	EACH Prices	
				1-4	5+
<b>H.</b> 22 x 0.6 x 1.8	300	Lt. Brown	<b>351-0287</b>	<b>\$24.95</b>	<b>\$22.46</b>
<b>I.</b> 22 x 0.6 x 1.8	400	Orange	<b>351-0288</b>	<b>24.95</b>	<b>22.46</b>
<b>J.</b> 22 x 0.6 x 1.8	600	Brown	<b>351-0289</b>	<b>24.95</b>	<b>22.46</b>
<b>K.</b> 22 x 0.6 x 1.8	800	Blue	<b>351-0290</b>	<b>24.95</b>	<b>22.46</b>



**A Premium Rubber Pumice Wheels, Points and Cylinders**

Contain pumice abrasive for light cutting, deburring parting lines, shaping and polishing softer metals. Excellent for scratch removal. GK-9 leaves a smooth finish on soft metal. Available in 5/8" dia. knife edge with 1/16" arbor hole. Max. operating speed: 25,000rpm. GK-10 is longer lasting and cuts fast too. Available in 5/8" dia. knife edge with 1/16" arbor hole and in points and cylinders mounted on 3/32" shanks. Max. operating speed: 20,000rpm. See p. 131 for mandrels.

Style	Dia.	Box of 100		Box of 1,000	
		Item#	Each	Item#	Each
GK-9 Knife Edge Wheel	5/8"	<b>845-2050</b>	<b>\$39.95</b>	<b>845-2055</b>	<b>\$350.00</b>
GK-10 Knife Edge Wheel	5/8"	<b>845-2060</b>	<b>24.95</b>	<b>845-2061</b>	<b>195.00</b>

Style	Dia. x L	Item#	PKG. of 10	
			1-9	10+
GK-10 Mounted Point	1/4" x 5/8"	<b>845-2065</b>	<b>\$9.95</b>	<b>\$8.96</b>
GK-10 Mounted Cylinder	1/4" x 1/2"	<b>845-2064</b>	<b>9.95</b>	<b>8.96</b>



**B - D Rubber Pumice Wheels**

Soft, flexible rubber wheels contain pumice abrasive. The light action produces a smooth finish on soft metals. All with 1/16" arbor hole. Max. operating speed: 25,000rpm. See p. 131 for mandrels.

Style	Dia. x Thick	Pkg. of 10		Box of 100	
		Item#	Each	Item#	Each
<b>B. 822</b>	5/8" x 3/32"	<b>845-2101</b>	<b>\$5.25</b>	<b>845-2102</b>	<b>\$38.35</b>
<b>C. 888</b>	7/8" x 1/8"	<b>845-2151</b>	<b>6.85</b>	<b>845-2152</b>	<b>48.30</b>
<b>D. 999</b>	5/8" tapered	<b>845-2001</b>	<b>7.10</b>	<b>845-2002</b>	<b>49.95</b>



**E - G Rubber SiC**

All-purpose hard rubberized abrasive. Contains silicon carbide grit and can be used for deburring, light grinding and smoothing on both hard and soft metals. Boxed per 100 pieces. All with 1/16" arbor hole. Max. operating speed: 30,000rpm. See p. 131 for mandrels.

Style	Dia. x Thick	Box of 100	
		Item#	Each
<b>E. Wheel</b>	7/8" x 1/8"	<b>845-2200</b>	<b>\$11.95</b>
<b>F. Cylinder</b>	1/4" x 7/8"	<b>845-2400</b>	<b>11.95</b>
<b>G. Bullet</b>	1/4" x 1"	<b>845-2450</b>	<b>33.00</b>

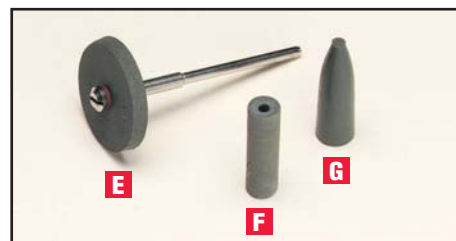

**H - K Rubber Polishing Rods**

For polishing of cavities and slots. Specially formulated rubber with silicon carbide for superior results. Available in three color-coded grits: dark brown – extra-hard, 220 grit, prepolishers for nonprecious alloys, for stock removal when extra pressure is needed; blue – coarse, 100 grit, prepolishers for coarse cutting; and gray – medium, 220 grit, for high-glaze polish on nonprecious alloys. Rods are approximately 1" long and are available in 2, 3 and 4mm diameters. Can be dressed to a sharp point with our Dressing Stone #145-1240 (see below). Max. operating speed: 15,000rpm. Use with 3/32" shank mandrels as listed in ordering chart.

Color	Diameter	Pkg. Item#	Pkg. of 25	Box		Use with Mandrel	
				Item#	of 100	Item#	Each
<b>H. Dk. Brown</b>	2mm	<b>145-1270</b>	<b>\$10.50</b>	<b>145-1241</b>	<b>\$36.90</b>	<b>145-1217</b>	<b>\$3.30</b>
	3mm	<b>145-1271</b>	<b>10.50</b>	<b>145-1242</b>	<b>36.90</b>	<b>145-1218</b>	<b>3.30</b>
	4mm	<b>145-1272</b>	<b>12.95</b>	<b>145-1243</b>	<b>45.40</b>	<b>145-1219</b>	<b>3.55</b>
<b>I. Blue</b>	2mm	<b>145-1273</b>	<b>10.50</b>	<b>145-1244</b>	<b>36.90</b>	<b>145-1217</b>	<b>3.30</b>
	3mm	<b>145-1274</b>	<b>10.50</b>	<b>145-1245</b>	<b>36.90</b>	<b>145-1218</b>	<b>3.30</b>
	4mm	<b>145-1275</b>	<b>12.95</b>	<b>145-1246</b>	<b>45.40</b>	<b>145-1219</b>	<b>3.55</b>
<b>J. Gray</b>	2mm	<b>145-1276</b>	<b>10.50</b>	<b>145-1247</b>	<b>36.90</b>	<b>145-1217</b>	<b>3.30</b>
	3mm	<b>145-1277</b>	<b>10.50</b>	<b>145-1248</b>	<b>36.90</b>	<b>145-1218</b>	<b>3.30</b>
	4mm	<b>145-1278</b>	<b>12.95</b>	<b>145-1249</b>	<b>45.40</b>	<b>145-1219</b>	<b>3.35</b>
<b>K. 3mm Rod Mandrel</b>	3/32" shank					<b>145-1218</b>	<b>3.30</b>



**L Dressing Stone – For use with rubber polishing rods**

Has tapered center hole for forming a point on rubber polishing rods. Measures 3/4" dia.

Description	Item#	Each
Dressing Stone	<b>145-1240</b>	<b>\$3.75</b>

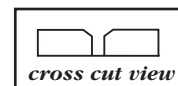

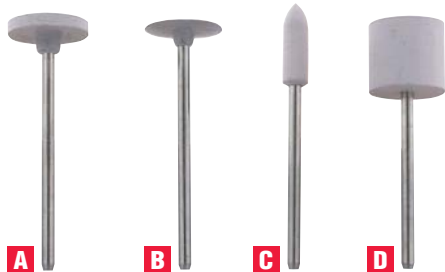

## A - H PT8 Polishers

Moderately hard yet flexible silicone rubber polishers with aluminum oxide for creating smooth, uniform finishes, especially on hard metals. Conform to surfaces and hold their edges. Ideal for removing scale and scratches. Mounted have  $\frac{3}{32}$ " shanks, and unmounted have  $\frac{1}{16}$ " arbor holes (see p. 131 for mandrels). Available in two grits: gray (medium) and lilac (fine).

Shape	Size	Color	Item#	Pkg. of 10	Item#	Box of 100
A. SE Wheel, mtd.	$\frac{5}{8}$ "	Gray	<b>145-1351</b>	<b>\$20.25</b>	<b>145-1350</b>	<b>\$137.80</b>
		Lilac	<b>145-1367</b>	<b>20.25</b>	<b>145-1366</b>	<b>137.80</b>
B. KE Wheel, mtd.	$\frac{5}{8}$ "	Gray	<b>145-1353</b>	<b>20.25</b>	<b>145-1352</b>	<b>137.80</b>
		Lilac	<b>145-1369</b>	<b>20.25</b>	<b>145-1368</b>	<b>137.80</b>
C. Point, mtd.	$\frac{3}{16}$ " x $\frac{5}{8}$ "	Gray	<b>145-1347</b>	<b>20.25</b>	<b>145-1346</b>	<b>137.80</b>
		Lilac	<b>145-1363</b>	<b>20.25</b>	<b>145-1362</b>	<b>137.80</b>
D. Cylinder, mtd.	$\frac{1}{2}$ " x $\frac{1}{2}$ "	Gray	<b>145-1349</b>	<b>30.25</b>	<b>145-1348</b>	<b>206.70</b>
		Lilac	<b>145-1365</b>	<b>30.25</b>	<b>145-1364</b>	<b>206.70</b>
E. SE Wheel	$\frac{7}{8}$ "	Gray	<b>145-1341</b>	<b>7.50</b>	<b>145-1340</b>	<b>51.10</b>
		Lilac	<b>145-1357</b>	<b>7.50</b>	<b>145-1356</b>	<b>51.10</b>
F. KE Wheel	$\frac{7}{8}$ "	Gray	<b>145-1343</b>	<b>7.50</b>	<b>145-1342</b>	<b>51.10</b>
		Lilac	<b>145-1359</b>	<b>7.50</b>	<b>145-1358</b>	<b>51.10</b>
Shape	Size	Grit	Item#	Pkg. of 25	Item#	Box of 100
G. Rod	3mm x 1"	Gray	<b>145-1345</b>	<b>\$15.65</b>	<b>145-1344</b>	<b>\$51.10</b>
		Lilac	<b>145-1361</b>	<b>16.50</b>	<b>145-1360</b>	<b>51.10</b>
Description					Item#	Each
H. 3mm Rod Mandrel, $\frac{3}{32}$ " shank					<b>145-1218</b>	<b>\$3.30</b>



## I Polishing Points and Wheels – $\frac{3}{32}$ " Shank

Specially formulated rubber polishers with silicon carbide for use on metallic and non-metallic surfaces. Work better and last longer than many other types of rubber polishers. Available in two grits: brown (fine) for removing scale and scratches and green (very fine) for imparting a high-shine final finish. Max. operating speeds: 20,000rpm for brown and 15,000rpm for green.

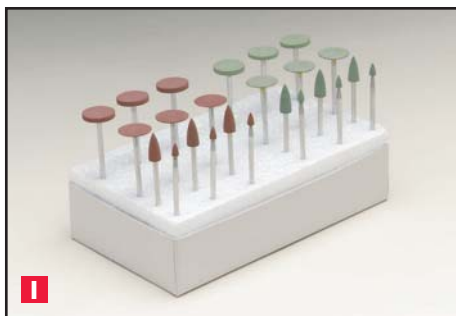

Shape	Size (mm)	Brown Item#	Green Item#	Pkg. of 10	
SE Wheel	15.0 x 1.7	<b>145-1413</b>	<b>145-1415</b>	<b>\$14.20</b>	
KE Wheel	15.0 x 2.0	<b>145-1147</b>	<b>145-1161</b>	<b>13.50</b>	
Small Point	3.1 x 6.0	<b>145-1405</b>	<b>145-1407</b>	<b>12.89</b>	
Large Point	4.4 x 12.7	<b>145-1143</b>	<b>145-1157</b>	<b>12.20</b>	
Description				Item#	Each
I. 24-Piece Set (three of each shape/color)				<b>145-1100</b>	<b>\$31.35</b>

## J - N Edenta Titanium Polishers

Silicone rubber polishers for use on titanium and other hard metals. Available in two grits: gray (medium) for removing scratches and flaws and blue (fine) for imparting final finish. All have  $\frac{1}{16}$ " arbor holes (see p. 131 for mandrels). Max. operating speeds: 20,000rpm for gray and 10,000rpm for blue.



J

K

L

M

N

Shape	Size (mm)	Color	Item#	Pkg. of 10	Item#	Box of 100
J. SE Wheel	22 x 3	Gray	<b>145-3209</b>	<b>\$5.50</b>	<b>145-3208</b>	<b>\$45.00</b>
		Blue	<b>145-3219</b>	<b>5.50</b>	<b>145-3218</b>	<b>45.00</b>
K. KE Wheel	22 x 3	Gray	<b>145-3207</b>	<b>5.50</b>	<b>145-3206</b>	<b>45.00</b>
		Blue	<b>145-3217</b>	<b>5.50</b>	<b>145-3216</b>	<b>45.00</b>
L. Point	23 x 6	Gray	<b>145-3205</b>	<b>5.50</b>	<b>145-3204</b>	<b>45.00</b>
		Blue	<b>145-3215</b>	<b>5.50</b>	<b>145-3214</b>	<b>45.00</b>
M. Cylinder	22 x 6	Gray	<b>145-3203</b>	<b>5.50</b>	<b>145-3202</b>	<b>45.00</b>
		Blue	<b>145-3213</b>	<b>5.50</b>	<b>145-3212</b>	<b>45.00</b>
N. Rod	22 x 3	Gray	<b>145-3201</b>	<b>5.50</b>	<b>145-3200</b>	<b>45.00</b>
		Blue	<b>145-3211</b>	<b>5.50</b>	<b>145-3210</b>	<b>45.00</b>

**Cera – Ceramic abrasive and synthetic rubber combine to produce a near mirror-like shine with minimal wear.**

This revolutionary abrasive consists of ceramic particles mixed in a long-lasting synthetic rubber carrier. Its fast breakdown rate ensures ceramic particles are always exposed to the polishing surface. Resists clogging for high efficiency. Blends well and removes stoning scratches with ease, leaving a smooth finish. Cuts safely and smoothly. Great for cleaning, deburring,

precision grinding, polishing and super finishing of molds, dies, small electrical components, sensitive equipment and more. Use dry or wet on steels, alloys and stainless steel. Work with light pressures. Choose from points, wheels and sticks. Refer to chart at right for grit designations.

Color	Designation	Approx. Grit
Gray	Extra-Coarse	46
Red	Coarse	80
Blue	Medium	120
Green/Yellow	Fine	220
Purple	Extra-Fine	320
Orange	Ultra-Fine	500

**A - D Cera Points – 3/32" Shank**

Points mounted on 3/32" stainless steel shanks. Max. operating speed: 30,000rpm.

Dimensions (mm)	Red Item#	Blue Item#	Green Item#	Purple Item#	Orange Item#	EACH Prices	
						1-11	12+*
<b>A.</b> 10 x 22	<b>351-0624</b>	<b>351-0625</b>	<b>351-0626</b>	<b>351-0627</b>	<b>351-0628</b>	<b>\$5.10</b>	<b>\$4.59</b>
<b>B.</b> 5 x 15	<b>351-0600</b>	<b>351-0601</b>	<b>351-0603</b>	<b>351-0604</b>	<b>351-0605</b>	<b>3.90</b>	<b>3.51</b>
<b>C.</b> 8 x 20	<b>351-0606</b>	<b>351-0607</b>	<b>351-0609</b>	<b>351-0610</b>	<b>351-0611</b>	<b>3.90</b>	<b>3.51</b>
<b>D.</b> 10 x 20	<b>351-0612</b>	<b>351-0613</b>	<b>351-0615</b>	<b>351-0616</b>	<b>351-0617</b>	<b>4.10</b>	<b>3.69</b>

\*Quantity discount for orders of one item# only, not assorted.

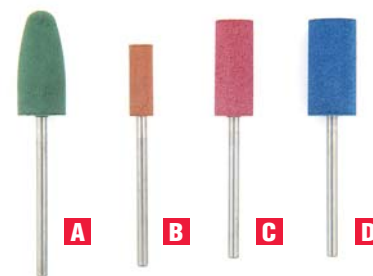

**E - G Cera Wheels**

Unmounted wheels with 1/16" arbor holes. Max. operating speed: 18,000rpm. See p. 131 for mandrels.

Dimensions (mm)	Red Item#	Blue Item#	Green Item#	Orange Item#	PKG. of 10	
					1-4	5+*
<b>E.</b> 18 x 3	<b>352-0101</b>	<b>352-0102</b>	<b>352-0103</b>	<b>352-0104</b>	<b>\$18.50</b>	<b>\$16.65</b>
<b>F.</b> 18 x 2	–	<b>352-0108</b>	<b>352-0109</b>	<b>352-0111</b>	<b>18.50</b>	<b>16.65</b>
<b>G.</b> 18 x 1	–	<b>352-0114</b>	<b>352-0115</b>	<b>352-0117</b>	<b>18.50</b>	<b>16.65</b>

\*Quantity discount for orders of one item# only, not assorted.

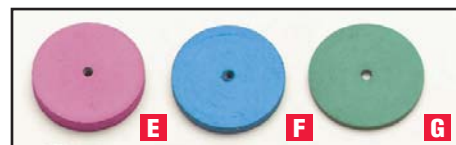

**H Cera Sticks**

Each stick consists of a block of Cera abrasive mounted on a plastic holder. Material and holder are both flexible, so they conform well to irregular surfaces and hard-to-reach areas. Three slots on back of holder serve as convenient hacksaw guides for removing tip of Cera material once worn. Blocks measure 2 3/4"L x 3/8"W x 1/4"T. Sticks measure 7" overall length. Available individually or in a set of all five grits.

Color	Item#	EACH Prices	
		1-4	5+
Gray	<b>352-0150</b>	<b>\$10.95</b>	<b>\$9.86</b>
Red	<b>352-0151</b>	<b>10.95</b>	<b>9.86</b>
Blue	<b>352-0152</b>	<b>10.95</b>	<b>9.86</b>
Yellow	<b>352-0153</b>	<b>10.95</b>	<b>9.86</b>
Purple	<b>352-0154</b>	<b>10.95</b>	<b>9.86</b>
Description	Item#	Each	
<b>H.</b> 5-Piece Set	<b>352-0155</b>	<b>\$45.95</b>	



**I Diamond Dressing Block**

Solid steel block with diamond coating for fast dressing and shaping of any of our rubberized abrasives. One side is grooved for shaping rods, points and knife edge wheels. Other side is flat for dressing square edge wheels. Measures 3 1/2" overall length.

Description	Item#	Each
Diamond Dressing Block	<b>145-1315</b>	<b>\$43.95</b>



## Cratex®

A tough, resilient, rubberized abrasive made of silicon carbide grains evenly dispersed in premium-grade, oil-resistant chemical rubber. Features unique cushion action that allows abrasive grains to cut freely, smoothly and softly without gouging the work surface. Resists clogging for high efficiency. Ideal for a broad range of applications in which metallic or nonmetallic surfaces must be smoothed and polished without loss of dimensional tolerances. Can be used with water or typical shop coolants. Will not harden or soften in storage.

Diameter	Max. RPM*
1" with 1/16" or 1/8" AH	25,000
1" to 1 1/2" with 1/4" AH	20,000
2" with 1/4" AH	10,500
2 1/2" with 1/4" AH	8,300
3" with 1/4" AH	7,000
4" with 1/2" AH	5,250
5" with 1/2" AH	4,200
6" with 1/2" AH	3,500

\*Frequently, 30-80% slower speeds than maximum yield optimum results.

Color	Grade	Grit
Dark Green	Coarse	40
Brown	Medium	90
Red	Fine	120
Light Green	Extra-Fine	240

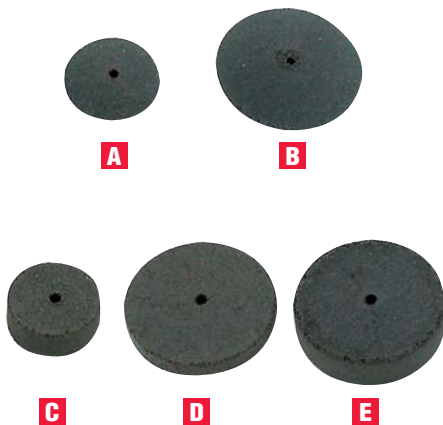

### A, B Cratex® Small Tapered-Edge Wheels

Dia. x Thick x AH	Style	40 Grit Item#	90 Grit Item#	120 Grit Item#	240 Grit Item#	Box of 100
A. 5/8" x 3/32" x 1/16"	2	149-0002	148-0002	147-0002	146-0002	\$39.95
B. 1" x 1/8" x 1/16"	5	149-0005	148-0005	147-0005	146-0005	69.75

### C - E Cratex® Small Straight-Edge Wheels

Dia. x Thick x AH	Style	40 Grit Item#	90 Grit Item#	120 Grit Item#	240 Grit Item#	Box of 100
C. 5/8" x 3/32" x 1/16"	53	149-0053	148-0053	147-0053	146-0053	\$43.95
5/8" x 1/8" x 1/16"	54	149-0054	148-0054	147-0054	146-0054	53.00
5/8" x 1/4" x 1/16"	59	149-0059	148-0059	147-0059	146-0059	58.95
D. 7/8" x 1/8" x 1/16"	74	149-0074	148-0074	147-0074	146-0074	55.95
E. 1" x 1/8" x 1/16"	80	149-0080	148-0080	147-0080	146-0080	75.75
1" x 1/4" x 1/16"	88	149-0088	148-0088	147-0088	146-0088	98.40



### F, G Small Wheel Mandrels

Maximum operating speed is 25,000rpm for 1/2" overhang (exposed mandrel length) or less. For each additional 1/4" of overhang, maximum operating speed is decreased by at least 20%. Use light work pressure. Made of high-quality steel.

Style	Shank	For Hole	Item#	EACH Prices	
				1-11	12+
F. 2	3/32"	1/16"	840-3183	\$3.60	\$3.00
G. 3	1/8"	1/16"	840-3186	4.45	3.71



### H, I Cratex® Small Cylinders

Dia. x L x AH	Style	40 Grit Item#	90 Grit Item#	120 Grit Item#	240 Grit Item#	Box of 100
H. 1/4" x 1/2" x 1/16"	4	149-0004	148-0004	147-0004	146-0004	\$43.95
I. 1/4" x 7/8" x 1/16"	6	149-0006	148-0006	147-0006	146-0006	51.95



### J, K Cratex® Points

Dia. x L x AH	Style	40 Grit Item#	90 Grit Item#	120 Grit Item#	240 Grit Item#	Box of 100
J. 9/32" x 1" x 1/16"	8	149-0008	148-0008	147-0008	146-0008	\$51.95
K. 3/8" x 5/8" x 1/16"	10	149-0010	148-0010	147-0010	146-0010	55.10



### L - O Tapered Thread Mandrels

For use with felt bobs or cones. Right-handed threads.

Style	Shank	For Hole	Length of Taper	Item#	EACH Prices	
					3-9	12+
L. 3	3/32"	1/16"	3/16"	840-3070*	\$.85	\$.71
M. 0	3/32"	1/16"	3/8"	840-3040*	.85	.71
N. 13	1/8"	1/16"	3/16"	840-3090*	.85	.71
O. 30	1/8"	1/16"	3/8"	840-3120*	.85	.71

\*Three-piece minimum; please order in multiples of three.



**A - D Cratex® Large Straight-Edge Wheels**

Dia. x Thick x AH	Style	40 Grit Item#	90 Grit Item#	120 Grit Item#	240 Grit Item#	Each
<b>A.</b> 2" x 1/4" x 1/4"	204	<b>149-0204</b>	<b>148-0204</b>	<b>147-0204</b>	<b>146-0204</b>	<b>\$6.75</b>
<b>B.</b> 3" x 1/8" x 1/4"	302	<b>149-0302</b>	<b>148-0302</b>	<b>147-0302</b>	<b>146-0302</b>	<b>9.85</b>
3" x 1/2" x 1/4"	308	<b>149-0308</b>	<b>148-0308</b>	<b>147-0308</b>	<b>146-0308</b>	<b>18.25</b>
<b>C.</b> 4" x 1/4" x 1/2"	404	<b>149-0404</b>	<b>148-0404</b>	<b>147-0404</b>	<b>146-0404</b>	<b>19.25</b>
4" x 1/2" x 1/2"	408	<b>149-0408</b>	<b>148-0408</b>	<b>147-0408</b>	<b>146-0408</b>	<b>27.30</b>
<b>D.</b> 6" x 1/4" x 1/2"	604	<b>149-0604</b>	<b>148-0604</b>	<b>147-0604</b>	<b>146-0604</b>	<b>36.95</b>
6" x 1/2" x 1/2"	608	<b>149-0608</b>	<b>148-0608</b>	<b>147-0608</b>	<b>146-0608</b>	<b>53.10</b>



**E - G Large Wheel Mandrel and Arbors**

Large wheel mandrel fits wheels up to 3" dia. x 1/2" thick or less. Max. operating speeds with 1/2" overhang or less: 15,000rpm for 1 1/2" wheels; 8,300rpm for 2" wheels; 7,000rpm for 3" wheels (based on 5,500 surface feet per minute). Best results are usually obtained at 30% to 80% of max. operating speed. Use light working pressure. Arbors are used to mount polishing, buffing and grinding wheels with 1/2" arbor holes onto polishing or lapping motors.

Style	Shank	For Hole	Item#	EACH Prices	
<b>E.</b> 1342	1/4"	1/4"	<b>840-3184</b>	1-11	12+
	For Motor, Shaft	For Wheel Thickness	Overall Length	Item#	Each
<b>F.</b> 26-1 Right, 1/2"	1"	1"	4 1/4"	<b>840-4550</b>	<b>\$18.00</b>
<b>G.</b> 26-1 Left, 1/2"	1"	1"	4 1/4"	<b>840-4500</b>	<b>18.00</b>

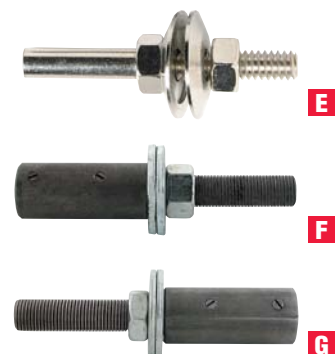

**H - J Cratex® Cones**

Dia. x L x AH	Style	40 Grit Item#	90 Grit Item#	120 Grit Item#	240 Grit Item#	Each
<b>H.</b> 5/8"-1/4" x 1" x 1/4"	1340	<b>149-1340</b>	<b>148-1340</b>	<b>147-1340</b>	<b>146-1340</b>	<b>\$4.65</b>
<b>I.</b> 7/8" x 1" x 1/4" *	1350	<b>149-1350</b>	<b>148-1350</b>	<b>147-1350</b>	<b>146-1350</b>	<b>8.85</b>
<b>J.</b> 7/8" x 1 3/4" x 1/4" *	4707	<b>149-4707</b>	<b>148-4707</b>	<b>147-4707</b>	<b>146-4707</b>	<b>12.85</b>

\*Threaded inserts



**K Cone Mandrel - 1/4" Shank**

For Cratex cone styles 1340, 1350 and 4707. Maximum operating speed is 20,000rpm for 1/2" overhang (exposed mandrel length) or less. For each additional 1/4" of overhang, maximum operating speed is decreased by at least 20%. Use light work pressure. Made of high-quality steel.

Style	Shank	For Hole	Item#	EACH Prices	
1341	1/4"	1/4"	<b>840-3180</b>	1-11	12+



**L - O Cratex® Rods and Sticks**

Dimensions	Style	40 Grit Item#	90 Grit Item#	120 Grit Item#	240 Grit Item#	Each
<b>L.</b> 6"L x 1/4" dia.	046	<b>149-0046</b>	<b>148-0046</b>	<b>147-0046</b>	<b>146-0046</b>	<b>\$5.25</b>
<b>M.</b> 6"L x 3/8" dia.	066	<b>149-0066</b>	<b>148-0066</b>	<b>147-0066</b>	<b>146-0066</b>	<b>5.95</b>
<b>N.</b> 6"L x 1/2" dia.	086	<b>149-0090</b>	<b>148-0090</b>	<b>147-0090</b>	<b>146-0090</b>	<b>8.35</b>
<b>O.</b> 6"L x 1/2" sq.	6404	<b>149-6404</b>	<b>148-6404</b>	<b>147-6404</b>	<b>146-6404</b>	<b>9.85</b>



**P Cratex® Kits**

Kit #777 contains 80 small wheels and points in four grits: coarse (40 grit), medium (90 grit), fine (120 grit) and extra-fine (240 grit). Also includes four mandrels with 1/8" shanks. Kit #778 contains 64 points in four grits: coarse (40 grit), medium (90 grit), fine (120 grit) and extra-fine (240 grit). Also includes four mandrels with 1/8" shanks. Both kits packaged in a clear divided box for easy selection.

Description	Item#	Each
<b>P.</b> Cratex Kit #777	<b>146-7770</b>	<b>\$66.65</b>
Cratex Kit #778	<b>146-7780</b>	<b>79.25</b>



## A - F Brightboy®

Brightboy is made of aluminum oxide with a resilient rubber bond, making it long-lasting. Its uniform cutting action makes it ideal for deburring and scratch removal on nonferrous metals. Also for light grinding of carbon steel. Permits cushioned action on flat and contoured surfaces. The texture and cutting action are always uniform. Brightboy requires no additives such as cutting compounds. Not for use on tapered spindles. See p. 131 for mandrels, p. 136 for arbors.



### A Brightboy® Wheels

Dia. x Thick x AH	Max. RPM	Style	Item#	EACH Prices	
				1-9	10+
1½" x ¾" x ¼"	15,000	5	<b>275-0050</b>	<b>\$11.90</b>	<b>\$8.33</b>
2" x ¼" x ¼"	7,625	17	<b>275-0170</b>	<b>18.95</b>	—
3" x ¾" x ¼"	5,060	30	<b>275-0300</b>	<b>25.10</b>	<b>17.57</b>
3" x ½" x ¼"	5,060	31	<b>275-0310</b>	<b>26.95</b>	<b>18.87</b>
3" x ¾" x ½"	5,060	33	<b>275-0330</b>	<b>31.60</b>	<b>22.12</b>
4" x ¼" x ½"	3,800	38	<b>275-0380</b>	<b>30.50</b>	—
4" x ½" x ½"	3,800	40	<b>275-0400</b>	<b>34.50</b>	<b>24.15</b>
4" x ¾" x ½"	3,800	41	<b>275-0410</b>	<b>42.50</b>	<b>29.75</b>

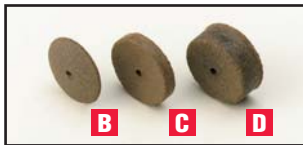

### B - D Brightboy® Discs

Dia. x Thick x AH	Max. RPM	Pkg. of 10		Box of 100	
		Item#	Each	Item#	Each
<b>B.</b> ⅝" x ¼" x ¼" *	25,000	<b>277-0031</b>	<b>\$12.05</b>	<b>277-0032</b>	<b>\$76.50</b>
<b>C.</b> ⅝" x ⅛" x ¼"	25,000	<b>277-0061</b>	<b>12.05</b>	<b>277-0062</b>	<b>79.50</b>
<b>D.</b> ⅝" x ¼" x ¼"	25,000	<b>277-0071</b>	<b>13.25</b>	<b>277-0072</b>	<b>87.75</b>

\*Knife edge



### E Brightboy® Stick and Holder

Used for cleaning otherwise unreachable deep cavities. Tip can be easily reshaped.

Description	Dimensions	Item#	Each
Stick and Holder	6"L x ⅝" dia.	<b>277-0065</b>	<b>\$16.50</b>
Replacement Stick	—	277-0063	7.95



### F Brightboy® Tablet

Used for removing scratches or rust and for general surface cleaning and finishing.

Description	Dimensions	Item#	Each
Tablet	2¼"L x 1⅛"W x ⅜"H	<b>277-0066</b>	<b>\$5.65</b>



### G Rugi Mounted Cylinders – ⅛" and ¼" Shanks

These highly resilient mounted cylinders are made with a rubberized abrasive bond so unique, both the abrasive material and the bond are patented. Easy to shape for contours, yet vibration-free. For fine grinding. Will not scratch work surface. Durable and elastic. Lower loading than vitrified and resin bond points. Excellent for grinding turbine blades; deburring openings of jet engines and turbine parts, gears and slots; finishing welds on stainless steel; and finishing glass, rubber and plastic molds. Available on ⅛" and ¼" shanks. Max. operating speed: 30,000rpm for ⅛" shanks, 20,000rpm for ¼" shanks.

Dia. x L (mm)	Shank	80 Grit	120 Grit	180 Grit	220 Grit	Pkg. of 10
		Red Item#	Black Item#	Brown Item#	Green Item#	
6 x 15	3.2mm (⅛")	<b>353-0002</b>	<b>353-0003</b>	<b>353-0004</b>	<b>353-0005</b>	<b>\$20.40</b>
8 x 15	3.2mm (⅛")	<b>353-0006</b>	<b>353-0007</b>	<b>353-0008</b>	<b>353-0009</b>	<b>20.40</b>
10 x 15	3.2mm (⅛")	<b>353-0010</b>	<b>353-0011</b>	<b>353-0012</b>	<b>353-0013</b>	<b>20.40</b>
13 x 20	6.35mm (¼")	<b>353-0014</b>	<b>353-0015</b>	<b>353-0016</b>	<b>353-0017</b>	<b>26.95</b>
15 x 20	6.35mm (¼")	<b>353-0018</b>	<b>353-0019</b>	<b>353-0020</b>	<b>353-0021</b>	<b>29.75</b>
20 x 20	6.35mm (¼")	<b>353-0022</b>	<b>353-0023</b>	<b>353-0024</b>	<b>353-0025</b>	<b>36.60</b>
20 x 25	6.35mm (¼")	<b>353-0026</b>	<b>353-0027</b>	<b>353-0028</b>	<b>353-0029</b>	<b>42.55</b>
25 x 25	6.35mm (¼")	<b>353-0030</b>	<b>353-0031</b>	<b>353-0032</b>	<b>353-0033</b>	<b>54.60</b>

**GMX**

A long-lasting aluminum oxide abrasive in a unique composite of laminated cotton fiber in a rubber bond. GMX cuts and smooths in one operation, leaving a smooth, even finish. Discs can be dressed to conform to shape of workpiece. Mounted cylinders are popular for smoothing the inside of holes. Use 80 grit for deburring, 120 grit to remove parting lines and small burs, 180 and 320 grit for removing light scratches. See p. 131 for mandrels, p. 136 for arbors. Made in USA.

**A GMX Sticks**

Used for polishing and touching up molds, dies and metal parts. Less aggressive than finishing stones, GMX sticks produce a surprisingly smooth surface.

Dimensions	Grit	Item#	EACH Prices	
			1-11	12+
4"L x 1/4" square	80	<b>206-9250</b>	<b>\$3.75</b>	<b>\$3.19</b>
	120	<b>206-9260</b>	<b>3.75</b>	<b>3.19</b>
	180	<b>206-9270</b>	<b>3.75</b>	<b>3.19</b>
	320	<b>206-9280</b>	<b>5.25</b>	<b>4.46</b>
4"L x 1/4" round	80	<b>206-9320</b>	<b>6.85</b>	<b>5.82</b>
	120	<b>206-9325</b>	<b>6.85</b>	<b>5.82</b>
	180	<b>206-9330</b>	<b>6.85</b>	<b>5.82</b>
	320	<b>206-9335</b>	<b>7.95</b>	<b>6.76</b>
4"L x 1/2" round	80	<b>206-9340</b>	<b>7.50</b>	<b>6.38</b>
	120	<b>206-9345</b>	<b>7.50</b>	<b>6.38</b>
	180	<b>206-9350</b>	<b>7.50</b>	<b>6.38</b>
	320	<b>206-9355</b>	<b>8.85</b>	<b>7.52</b>
6"L x 1/4" round	80	<b>206-9360</b>	<b>9.75</b>	<b>8.29</b>
	120	<b>206-9365</b>	<b>9.75</b>	<b>8.29</b>
	180	<b>206-9370</b>	<b>9.75</b>	<b>8.29</b>
	320	<b>206-9375</b>	<b>11.25</b>	<b>9.56</b>
6"L x 1/2" round	80	<b>206-9380</b>	<b>10.35</b>	<b>8.80</b>
	120	<b>206-9385</b>	<b>10.35</b>	<b>8.80</b>
	180	<b>206-9390</b>	<b>10.35</b>	<b>8.80</b>
	320	<b>206-9395</b>	<b>11.95</b>	<b>10.16</b>



**B, C GMX Discs**

Dia. x Thick x AH	Grit	Max. RPM	Item#	EACH Prices	
				1-11	12+
<b>B.</b> 1" x 1/16" x 1/8"	120	36,290	<b>205-5204</b>	<b>\$3.65</b>	<b>\$3.10</b>
	180	36,290	<b>205-5206</b>	<b>3.65</b>	<b>3.10</b>
	320	36,290	<b>205-5208</b>	<b>4.25</b>	<b>3.61</b>
<b>C.</b> 1" x 1/8" x 1/8"	80	36,290	<b>205-5252</b>	<b>3.65</b>	<b>3.10</b>
	120	36,290	<b>205-5254</b>	<b>3.65</b>	<b>3.10</b>
	180	36,290	<b>205-5256</b>	<b>3.65</b>	<b>3.10</b>
	320	36,290	<b>205-5258</b>	<b>4.25</b>	<b>3.61</b>



**D, E GMX Wheels**

Dia. x Thick x AH	Grit	Max. RPM	Item#	EACH Prices	
				1-24	25+
<b>D.</b> 4" x 1/4" x 1/4"	80	9,075	<b>206-1050</b>	<b>\$13.50</b>	<b>\$12.15</b>
	120	9,075	<b>206-1060</b>	<b>13.50</b>	<b>12.15</b>
	180	9,075	<b>206-1070</b>	<b>13.50</b>	<b>12.15</b>
	320	9,075	<b>206-1080</b>	<b>14.95</b>	<b>13.46</b>
Dia. x Thick x AH	Grit	Max. RPM	Item#	EACH Prices	
				1-9	10+
<b>E.</b> 6" x 1/2" x 1/2"	80	6,050	<b>206-1750</b>	<b>\$48.95</b>	<b>\$44.06</b>
	120	6,050	<b>206-1760</b>	<b>48.95</b>	<b>44.06</b>
	180	6,050	<b>206-1770</b>	<b>48.95</b>	<b>44.06</b>
	320	6,050	<b>206-1780</b>	<b>55.95</b>	<b>50.36</b>



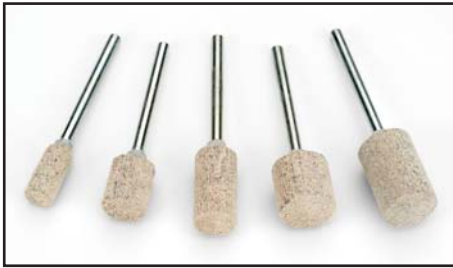

## A - E GMX Mounted Cylinders – 1/8" Shank

GMX is similar in construction to G-Flex, but it utilizes a unique rubber bond in addition to the muslin reinforcing for added resilience. GMX produces a slightly finer finish than G-Flex. Laminations run parallel to the shank to prevent the ends from chipping. Blending, finishing and polishing are combined in one simple operation. These mounted cylinders can be dressed to various shapes. Ideal for polishing mold runners and for deburring. See Grinding Wheel Institute publications for operating speeds of mounted cylinders. Available on 3mm shanks by special order.



### A Shape W163 – 1/2"L x 1/4" dia.

Grit	Shank	Item#	EACH Prices			
			1-11	12-71	72-143	144+
80	1/8"	<b>205-1632</b>	<b>\$4.85</b>	<b>\$4.12</b>	<b>\$3.64</b>	<b>\$3.25</b>
120	1/8"	<b>205-1634</b>	<b>4.85</b>	<b>4.12</b>	<b>3.64</b>	<b>3.25</b>
180	1/8"	<b>205-1636</b>	<b>4.85</b>	<b>4.12</b>	<b>3.64</b>	<b>3.25</b>
320	1/8"	<b>205-1638</b>	<b>5.45</b>	<b>4.63</b>	<b>4.09</b>	<b>3.65</b>

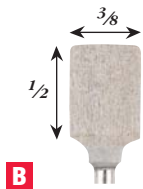

### B Shape W176 – 1/2"L x 3/8" dia.

Grit	Shank	Item#	EACH Prices			
			1-11	12-71	72-143	144+
80	1/8"	<b>205-1762</b>	<b>\$4.85</b>	<b>\$4.12</b>	<b>\$3.64</b>	<b>\$3.25</b>
120	1/8"	<b>205-1764</b>	<b>4.85</b>	<b>4.12</b>	<b>3.64</b>	<b>3.25</b>
180	1/8"	<b>205-1766</b>	<b>4.85</b>	<b>4.12</b>	<b>3.64</b>	<b>3.25</b>
320	1/8"	<b>205-1768</b>	<b>5.45</b>	<b>4.63</b>	<b>4.09</b>	<b>3.65</b>

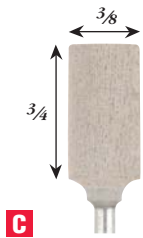

### C Shape W177 – 3/4"L x 3/8" dia.

Grit	Shank	Item#	EACH Prices			
			1-11	12-71	72-143	144+
80	1/8"	<b>205-1772</b>	<b>\$5.95</b>	<b>\$5.06</b>	<b>\$4.46</b>	<b>\$3.99</b>
120	1/8"	<b>205-1774</b>	<b>5.95</b>	<b>5.06</b>	<b>4.46</b>	<b>3.99</b>
180	1/8"	<b>205-1776</b>	<b>5.95</b>	<b>5.06</b>	<b>4.46</b>	<b>3.99</b>
320	1/8"	<b>205-1778</b>	<b>6.85</b>	<b>5.82</b>	<b>5.14</b>	<b>4.59</b>



### D Shape W185 – 1/2"L x 1/2" dia.

Grit	Shank	Item#	EACH Prices			
			1-11	12-71	72-143	144+
80	1/8"	<b>205-1852</b>	<b>\$4.85</b>	<b>\$4.12</b>	<b>\$3.64</b>	<b>\$3.25</b>
120	1/8"	<b>205-1854</b>	<b>4.85</b>	<b>4.12</b>	<b>3.64</b>	<b>3.25</b>
180	1/8"	<b>205-1856</b>	<b>4.85</b>	<b>4.12</b>	<b>3.64</b>	<b>3.25</b>
320	1/8"	<b>205-1858</b>	<b>5.45</b>	<b>4.63</b>	<b>4.09</b>	<b>3.65</b>

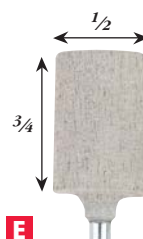

### E Shape W186 – 3/4"L x 1/2" dia.

Grit	Shank	Item#	EACH Prices			
			1-11	12-71	72-143	144+
120	1/8"	<b>205-1864</b>	<b>\$5.95</b>	<b>\$5.06</b>	<b>\$4.46</b>	<b>\$3.99</b>
320	1/8"	<b>205-1868</b>	<b>6.85</b>	<b>5.82</b>	<b>5.14</b>	<b>4.59</b>



**G-Flex Mounted Cylinders – 1/8" and 3mm Shanks**

G-Flex is made of laminated muslin with aluminum oxide grit in a strong resin bond. It's nonloading, somewhat resilient and long-lasting. G-Flex can grind and finish in one operation, and a special formulation keeps it from being too aggressive. G-Flex dresses well because the muslin laminates run parallel to the shank to prevent the ends from chipping. Ideal for polishing mold runners and for deburring. See Grinding Wheel Institute publications for operating speeds of mounted cylinders. Available on 1/8" and 3mm shanks. All 1/8" shank items also available on 3mm shanks by special order.



**A Shape W154 – 1/2"L x 3/16" dia.**

Grit	Shank	Item#	EACH Prices			
			1-11	12-71	72-143	144+
80	1/8"	<b>135-1542</b>	<b>\$4.85</b>	<b>\$4.12</b>	<b>\$3.64</b>	<b>\$3.25</b>
120	1/8"	<b>135-1544</b>	<b>4.85</b>	<b>4.12</b>	<b>3.64</b>	<b>3.25</b>
120	3mm	<b>136-1544</b>	<b>4.85</b>	<b>4.12</b>	<b>3.64</b>	<b>3.25</b>
180	1/8"	<b>135-1546</b>	<b>4.85</b>	<b>4.12</b>	<b>3.64</b>	<b>3.25</b>
320	1/8"	<b>135-1548</b>	<b>5.35</b>	<b>4.55</b>	<b>4.01</b>	<b>3.58</b>

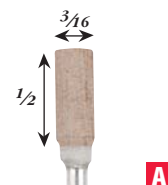

**B Shape W163 – 1/2"L x 1/4" dia.**

Grit	Shank	Item#	EACH Prices			
			1-11	12-71	72-143	144+
80	1/8"	<b>135-1632</b>	<b>\$4.85</b>	<b>\$4.12</b>	<b>\$3.64</b>	<b>\$3.25</b>
120	1/8"	<b>135-1634</b>	<b>4.85</b>	<b>4.12</b>	<b>3.64</b>	<b>3.25</b>
120	3mm	<b>136-1634</b>	<b>4.85</b>	<b>4.12</b>	<b>3.64</b>	<b>3.25</b>
180	1/8"	<b>135-1636</b>	<b>4.85</b>	<b>4.12</b>	<b>3.64</b>	<b>3.25</b>
320	1/8"	<b>135-1638</b>	<b>5.60</b>	<b>4.76</b>	<b>4.20</b>	<b>3.75</b>

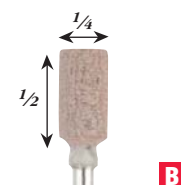

**C Shape W176 – 1/2"L x 3/8" dia.**

Grit	Shank	Item#	EACH Prices			
			1-11	12-71	72-143	144+
80	1/8"	<b>135-1762</b>	<b>\$4.95</b>	<b>\$4.21</b>	<b>\$3.71</b>	<b>\$3.32</b>
120	1/8"	<b>135-1764</b>	<b>4.95</b>	<b>4.21</b>	<b>3.71</b>	<b>3.32</b>
120	3mm	<b>136-1764</b>	<b>4.95</b>	<b>4.21</b>	<b>3.71</b>	<b>3.32</b>
180	1/8"	<b>135-1766</b>	<b>4.95</b>	<b>4.21</b>	<b>3.71</b>	<b>3.32</b>
320	1/8"	<b>135-1768</b>	<b>5.95</b>	<b>5.06</b>	<b>4.46</b>	<b>3.99</b>

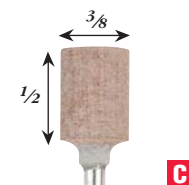

**D Shape W177 – 3/4"L x 3/8" dia.**

Grit	Shank	Item#	EACH Prices			
			1-11	12-71	72-143	144+
80	1/8"	<b>135-1772</b>	<b>\$5.95</b>	<b>\$5.06</b>	<b>\$4.46</b>	<b>\$3.99</b>
120	1/8"	<b>135-1774</b>	<b>5.95</b>	<b>5.06</b>	<b>4.46</b>	<b>3.99</b>
180	1/8"	<b>135-1776</b>	<b>5.95</b>	<b>5.06</b>	<b>4.46</b>	<b>3.99</b>
320	1/8"	<b>135-1778</b>	<b>6.75</b>	<b>5.74</b>	<b>5.06</b>	<b>4.52</b>

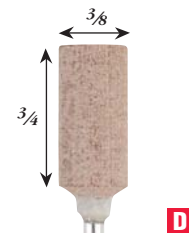

**E Shape W185 – 1/2"L x 1/2" dia.**

Grit	Shank	Item#	EACH Prices			
			1-11	12-71	72-143	144+
80	1/8"	<b>135-1852</b>	<b>\$4.95</b>	<b>\$4.21</b>	<b>\$3.71</b>	<b>\$3.32</b>
120	1/8"	<b>135-1854</b>	<b>4.95</b>	<b>4.21</b>	<b>3.71</b>	<b>3.32</b>
180	1/8"	<b>135-1856</b>	<b>4.95</b>	<b>4.21</b>	<b>3.71</b>	<b>3.32</b>
320	1/8"	<b>135-1858</b>	<b>5.45</b>	<b>4.63</b>	<b>4.09</b>	<b>3.65</b>

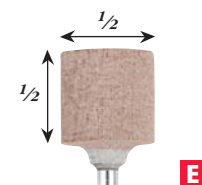



## A Unitized Mounted Points – 1/8" Shank

Ideal for a variety of deburring, blending, finishing and polishing applications. Consist of durable unitized material embedded with fine silicon carbide and mounted on 1/8" shanks. Conform to workpieces for consistent, uniform finishing without undercutting or gouging.

Style	Dia. x H	Max. RPM	Item#	Each
B42	1/2" x 3/4"	33,750	<b>845-0080</b>	<b>\$5.95</b>
B52	3/8" x 3/4"	45,300	<b>845-0081</b>	<b>4.85</b>
B90	1/2" x 1/2"	34,500	<b>845-0082</b>	<b>4.95</b>
W160	1/4" x 1/4"	81,300	<b>845-0083</b>	<b>2.95</b>
W183	1/2" x 1/4"	51,700	<b>845-0084</b>	<b>3.95</b>
W185	1/2" x 1/2"	34,500	<b>845-0085</b>	<b>4.95</b>

## B Quick-Change Cotton Fiber Wheels

Laminated cotton with resin-bonded aluminum oxide abrasive makes these wheels excellent for blending small welds and tool marks, deburring edges and finishing flat surfaces. They provide smooth, controlled grinding action to cut and finish in one step. Nonloading and long-lasting. Each comes mounted on a quick-change twist-on backing that fits 3M Roloc Disc Holders (see p. 61). Max. operating speed: 40,000rpm.



Dia.	Grit	Item#	Each
1"	80	<b>105-4000</b>	<b>\$2.50</b>
	120	<b>105-4002</b>	<b>2.50</b>
	180	<b>105-4004</b>	<b>2.50</b>
	320	<b>105-4006</b>	<b>2.50</b>
1 1/2"	80	<b>105-4008</b>	<b>2.65</b>
	120	<b>105-4010</b>	<b>2.65</b>
	180	<b>105-4012</b>	<b>2.65</b>
	320	<b>105-4014</b>	<b>2.65</b>
2"	80	<b>105-4016</b>	<b>2.95</b>
	120	<b>105-4018</b>	<b>2.95</b>
	180	<b>105-4020</b>	<b>2.95</b>
	320	<b>105-4022</b>	<b>2.95</b>



## C SUPRA® Unitized Wheels

Designed for deburring, cleaning and polishing applications, these wheels impart a uniform finish on both hard and soft metals. Can be shaped for getting into hard-to-reach areas.

Dia. x Thick x AH	Grit	Item#	EACH Prices	
			1-19	20+
3" x 3/4" x 1/4"	150	<b>845-0255</b>	<b>\$7.60</b>	<b>\$6.46</b>
	220	<b>845-0256</b>	<b>7.60</b>	<b>6.46</b>

## D, E Norton® Bear-Tex® Wheels

For quick removal of marks, scratches and surface imperfections. Also great for producing a consistent satin finish. Made of a cushion-type nylon web impregnated with silicon carbide abrasive. Bear-tex does not load or heat up. The 220 grit fine wheel is our most popular; the other grits are for faster finishing.



Dia. x Thick x AH	Grit	Max. RPM	Item#	EACH Prices					
				1-19	20+				
D. 3" x 3/4" x 1/4"	150	8,000	<b>845-0240</b>	<b>\$8.60</b>	<b>\$7.31</b>				
	220	8,000	<b>845-0250</b>	<b>8.60</b>	<b>7.31</b>				
Dia. x Thick x AH	Grit	Max. RPM	Item#	EACH Prices					
				1-2 3+					
				E. 6" x 1" x 1" *	120	6,000	<b>845-0261</b>	<b>\$57.85</b>	<b>\$52.07</b>
				6" x 1" x 1" **	120	6,000	<b>845-0260</b>	<b>57.85</b>	<b>52.07</b>
6" x 1" x 1" *	180	6,000	<b>845-0259</b>	<b>57.85</b>	<b>52.07</b>				
6" x 1" x 1" **	180	6,000	<b>845-0258</b>	<b>57.85</b>	<b>52.07</b>				

\*Comes with 1/2" bushing.

\*\*Comes with 3/8" bushing.

**3M™ Roloc™ Discs**

3M Roloc discs allow fast and efficient deburring, blending, polishing and finishing on all types of metal surfaces. They resist loading even under severe operating conditions. The Roloc design makes changing discs easy: the threaded male button on the back of each disc allows firm mounting to Roloc Disc Holder. Lock securely in place with a half-twist, or remove with half-twist in opposite direction. Discs are color-coded or have color-coded button for easy grit identification. Use with right-angle grinders.

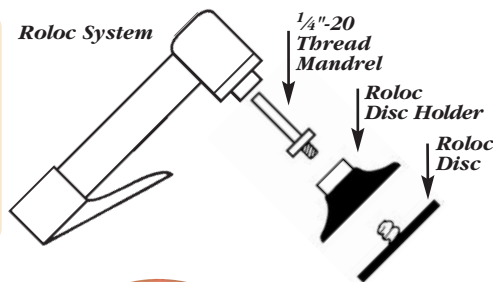

**A 3M™ Roloc™ Regalite™ Discs**

Made of 3M Cubitron and premium aluminum oxide grains resin-bonded onto heavy cloth backing. Mount on Roloc Disc Holders (see below).

Dia.	Max. RPM	60 Grit (Orange) Item#	80 Grit (Yellow) Item#	120 Grit (White) Item#	Pkg. of 50
1"	30,000	<b>105-3000</b>	<b>105-3005</b>	<b>105-3010</b>	<b>\$16.75</b>
1½"	30,000	<b>105-3015</b>	<b>105-3020</b>	<b>105-3025</b>	<b>19.80</b>
2"	25,000*	<b>105-3030</b>	<b>105-3035</b>	<b>105-3040</b>	<b>29.95</b>

\*Max. operating speed of 20,000rpm when used with the soft Roloc Disc Holder.

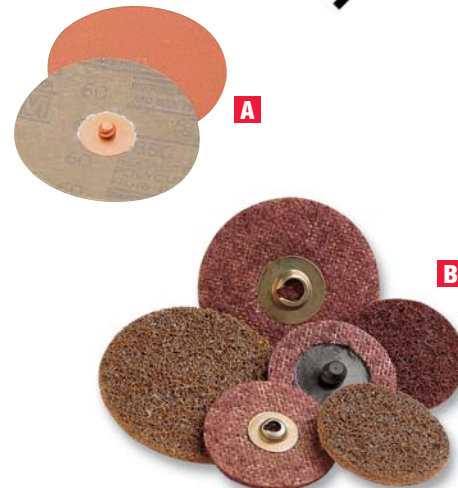

**B 3M™ Roloc™ Scotch-Brite™ Discs**

These discs remove burs with ease, leaving metal surfaces ready for final finishing. Can also be used to remove light rust, oxides and coatings. Mount on Roloc Disc Holders (see below).

Dia.	Max. RPM	Coarse Grit (Brown) Item#	Medium Grit (Maroon) Item#	Very Fine Grit (Blue) Item#	Pkg. of 10
1"	30,000	<b>845-1152</b>	<b>845-1151</b>	<b>845-1150</b>	<b>\$6.19</b>
1½"	30,000	<b>845-1155</b>	<b>845-1154</b>	<b>845-1153</b>	<b>6.35</b>
2"	25,000*	<b>845-1158</b>	<b>845-1157</b>	<b>845-1156</b>	<b>9.25</b>

\*Max. operating speed of 20,000rpm when used with the soft Roloc Disc Holder.

**C 3M™ Roloc™ Bristle Discs**

Designed for safely cleaning and stripping a wide variety of substances off metal. Cubitron mineral filled, they easily cut through corrosion, enamel paint, dried adhesive and more without damaging the underlying metal or compromising your safety. Because discs are completely load-resistant, each imparts a consistent finish throughout its life span. Mount on Roloc Disc Holders (see below).

Dia.	Trim Length	Max. RPM	50 Grit (Green) Item#	80 Grit (Yellow) Item#	120 Grit (White) Item#	Each
1"	5/8"	30,000	<b>145-1906</b>	<b>145-1902</b>	<b>145-1903</b>	<b>\$3.90</b>
2"	5/8" tapered	25,000*	<b>145-1907</b>	<b>145-1904</b>	<b>145-1905</b>	<b>6.50</b>

\*Max. operating speed of 20,000rpm when used with the soft Roloc Disc Holder.



**D 3M™ Roloc™ Radial Bristle Discs**

Use to remove surface contaminants, debur, blend and clean. Flexible bristles conform to surfaces and clean without damaging base material. Ideal for tight and awkward areas such as grooves and crevices. Use with 1" Roloc Disc Holder #105-3070 (see below).

Dia.	Trim Length	Max. RPM	50 Grit (Green) Item#	80 Grit (Yellow) Item#	120 Grit (White) Item#	Each
3"	1"	25,000	<b>145-1895</b>	<b>145-1900</b>	<b>145-1901</b>	<b>\$5.85</b>



**E - H 3M™ Roloc™ Disc Holders**

Rubber holders available in corresponding diameters and varying degrees of hardness for a variety of grinding and surface finishing applications. Harder holders cause discs to act more aggressively. Use soft pads for contour work. Holders are female threaded to receive any standard 1/4"-20 thread mandrel or our #105-3110. For use with Roloc discs (see above).

Dia.	Hardness	Max. RPM	Item#	Each
<b>E. 1"</b>	Medium	30,000	<b>105-3070</b>	<b>\$9.50</b>
<b>F. 1½"</b>	Hard	30,000	<b>105-3085</b>	<b>11.10</b>
	Medium	30,000	<b>105-3080</b>	<b>11.10</b>
	Soft	30,000	<b>105-3075</b>	<b>11.10</b>
<b>G. 2"</b>	X-Hard	25,000	<b>105-3105</b>	<b>14.30</b>
	Hard	25,000	<b>105-3100</b>	<b>11.50</b>
	Medium	25,000	<b>105-3095</b>	<b>11.50</b>
	Soft	20,000	<b>105-3090</b>	<b>11.80</b>
<b>H.</b>	Disc Holder Mandrel, 1/4" shank		<b>105-3110</b>	<b>1.95</b>





### A Satin Flap Wheels

Densest satin flap wheels on the market. Made of aluminum oxide. As each is used, fiber on the surface softens to create a beautiful finish with no cross-hatching or overlap marks. Medium produces a subtle line effect similar to a brush finish. Very Fine produces a glowing satin finish. Measure 4" dia. x 1" thick x 3/8" AH.

Description	Item#	Each
Medium	<b>142-3075</b>	<b>\$11.25</b>
Very Fine	<b>142-3070</b>	<b>9.50</b>



### B Fiber Flap Wheels – 1/4" Shank

Made of resilient aluminum oxide material. These wheels replace hand pads and reduce the need for finishing operations. For light deburring, polishing and satin finishing steel, nonferrous metal and wood. Ideal for surface contaminant removal. Maximum speed: 20,000rpm. Mounted on 1/4" shanks.

Dia. x Thickness	Grit	Item#	EACH Prices	
			1-2	3+
2" x 1"	Coarse	<b>108-0040</b>	<b>\$9.25</b>	<b>\$8.79</b>
	Medium	<b>108-0050</b>	<b>9.25</b>	<b>8.79</b>
	Fine	<b>108-0060</b>	<b>8.95</b>	<b>8.50</b>
	Very Fine	<b>108-0070</b>	<b>8.95</b>	<b>8.50</b>
3" x 1"	Coarse	<b>108-0140</b>	<b>11.50</b>	<b>10.93</b>
	Medium	<b>108-0150</b>	<b>11.50</b>	<b>10.93</b>
	Fine	<b>108-0160</b>	<b>11.50</b>	<b>10.93</b>
	Very Fine	<b>108-0170</b>	<b>11.50</b>	<b>10.93</b>



### C Mounted Hard FR Fiber Wheel – Fast Cut

Ideal for stock removal, this wheel has only slight resilience and cuts fast. Made of silicon carbide. Measures 1" dia. x 1/4" thick. 3/32" stainless steel shank.

Description	Item#	EACH Prices	
		1-11	12+
FR Fiber Wheel	<b>288-2272</b>	<b>\$2.75</b>	<b>\$2.48</b>



### D Mounted Flexible SLP Fiber Wheel – Fine Cut

A flexible yet firm unitized abrasive mounted wheel made of 180 grit pure alumina. Produces a fine, smooth finish. Measures 7/8" dia. x 1/8" thick. 3/32" stainless steel shank.

Description	Item#	EACH Prices	
		1-11	12+
SLP Fiber Wheel	<b>288-2276</b>	<b>\$1.10</b>	<b>\$0.99</b>



### E - H Mounted Satin Finish Wheels

Use these extra-thick wheels to create the exact degree of satin finish you want, from the soft and subtle texture of Extra Cut to the lustrous glow of Ultra-Fine. Made of dense-weave fiber for a uniform, nondirectional finish. Last much longer than conventional satin finish buffs. Measure approx. 7/8" dia. x 5/8" thick with 3/32" shank. To try all four grits, purchase our money-saving eight-piece intro pack.



Description	Color	Item#	EACH Prices		
			1-11	12+	
<b>E.</b> Extra Cut	ALO	Brown	<b>288-2260</b>	<b>\$0.88</b>	<b>\$0.79</b>
<b>F.</b> Medium	ALO	Red	<b>288-2262</b>	<b>.88</b>	<b>.79</b>
<b>G.</b> Very Fine	ALO	Dk. Red	<b>288-2264</b>	<b>.88</b>	<b>.79</b>
<b>H.</b> Ultra-Fine	SiC	Gray	<b>288-2266</b>	<b>.88</b>	<b>.79</b>
8-Piece Pack (two of each grit)			<b>288-2270</b>	<b>6.35</b>	<b>–</b>



**Flap Wheels – 1/8" and 1/4" Shanks**

Flap Wheels are made of aluminum oxide resin-bonded to cloth and permanently attached to the hub. They are resilient and can be used on flat or contoured surfaces. Particularly useful in flexible shaft handpieces and other rotary tools. Excellent for blending on metal surfaces, deburring and removing flash from machined parts and edge blending dies, molds and channels. Cutting action is slightly finer than normally expected from identical grit. Flap Wheels perform best when only slight pressure is applied.

**A - E Small Wheels**

	Dia. x Thickness	Shank	Max. RPM	Grit	Item#	EACH Prices	
						1-2	3+
<b>A.</b>	3/4" x 3/16"	1/8"	25,000	80	<b>107-5900</b>	<b>\$4.35</b>	<b>\$4.13</b>
				120	<b>107-5905</b>	<b>4.35</b>	<b>4.13</b>
				240	<b>107-5912</b>	<b>4.25</b>	<b>4.04</b>
				320	<b>107-5915</b>	<b>4.35</b>	<b>4.13</b>
<b>B.</b>	1 3/16" x 3/16"	1/8"	25,000	80	<b>107-5940</b>	<b>5.25</b>	<b>4.99</b>
				120	<b>107-5945</b>	<b>5.25</b>	<b>4.99</b>
				240	<b>107-5951</b>	<b>5.15</b>	<b>4.89</b>
				320	<b>107-5955</b>	<b>5.25</b>	<b>4.99</b>
<b>C.</b>	3/4" x 3/8"	1/8"	25,000	80	<b>107-5920</b>	<b>4.35</b>	<b>4.13</b>
				120	<b>107-5925</b>	<b>4.35</b>	<b>4.13</b>
				240	<b>107-5932</b>	<b>4.25</b>	<b>4.04</b>
				320	<b>107-5935</b>	<b>4.35</b>	<b>4.13</b>
<b>D.</b>	1" x 3/8"	1/8"	25,000	80	<b>107-5965</b>	<b>5.40</b>	<b>5.13</b>
				120	<b>107-5970</b>	<b>5.40</b>	<b>5.13</b>
				180	<b>107-5976</b>	<b>5.40</b>	<b>5.13</b>
				320	<b>107-5980</b>	<b>5.40</b>	<b>5.13</b>
<b>E.</b>	1 3/16" x 3/8"	1/8"	25,000	400	<b>107-5985</b>	<b>5.10</b>	<b>4.85</b>

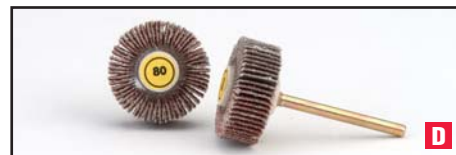

**F Medium Wheels**

	Dia. x Thickness	Shank	Max. RPM	Grit	Item#	EACH Prices	
						1-2	3+
<b>F.</b>	1 1/2" x 1/2"	1/4"	17,000	40	<b>107-7880</b>	<b>\$4.35</b>	<b>\$4.13</b>
				60	<b>107-7885</b>	<b>4.35</b>	<b>4.13</b>
				80	<b>107-7890</b>	<b>4.35</b>	<b>4.13</b>
				120	<b>107-7895</b>	<b>4.35</b>	<b>4.13</b>
				180	<b>107-7900</b>	<b>4.35</b>	<b>4.13</b>
				240	<b>107-7905</b>	<b>4.35</b>	<b>4.13</b>



**G Large Wheels**

	Dia. x Thickness	Shank	Max. RPM	Grit	Item#	EACH Prices	
						1-2	3+
<b>G.</b>	2" x 3/4"	1/4"	13,700	60	<b>107-6850</b>	<b>\$7.85</b>	<b>\$7.46</b>
				80	<b>107-6900</b>	<b>7.85</b>	<b>7.46</b>
				120	<b>107-6500</b>	<b>7.85</b>	<b>7.46</b>
				240	<b>107-6650</b>	<b>7.85</b>	<b>7.46</b>



**H Extra-Large Wheels**

	Dia. x Thickness	Shank	Max. RPM	Grit	Item#	EACH Prices	
						1-2	3+
<b>H.</b>	3" x 1/2"	1/4"	8,500	60	<b>107-7950</b>	<b>\$5.75</b>	<b>\$5.46</b>
				80	<b>107-7955</b>	<b>5.75</b>	<b>5.46</b>
				120	<b>107-7960</b>	<b>5.75</b>	<b>5.46</b>
				180	<b>107-7965</b>	<b>5.75</b>	<b>5.46</b>
				240	<b>107-7970</b>	<b>5.75</b>	<b>5.46</b>

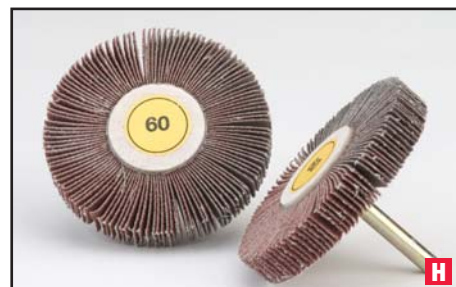

## A 3M™ Scotch-Brite™ EXL Unitized Wheels

For deburring, polishing and finishing applications. Excellent for use on titanium and special alloys. Designed to minimize heat buildup, these wheels withstand more pressure. Produce fine finishes on tooled pieces, on aerospace, automotive and electronic components and on medical instruments. Synthetic fiber and resin construction eliminates danger of flying wheel debris. Less messy than buffs with compounds. Choose from a wide selection of sizes and color-coded grits. See mandrels on p. 131.



Dia. x W x AH	Grit	Max. RPM	Item#	EACH Prices		
				1-9	10-49	50+
1/2" x 1/8" x 1/8"	Coarse	35,000	<b>845-1056</b>	<b>\$1.26</b>	<b>\$1.20</b>	<b>\$1.13</b>
	Medium	35,000	<b>845-1055</b>	<b>1.13</b>	<b>1.07</b>	<b>1.02</b>
1" x 1/8" x 1/8"	Coarse	35,000	<b>845-1060</b>	<b>2.13</b>	<b>2.02</b>	<b>1.92</b>
	Medium	35,000	<b>845-1059</b>	<b>1.91</b>	<b>1.81</b>	<b>1.72</b>
1" x 1/4" x 1/8"	Fine	30,000	<b>845-1061</b>	<b>1.95</b>	<b>1.85</b>	<b>1.76</b>
1 1/2" x 1/8" x 3/16"	Coarse	30,000	<b>845-1069</b>	<b>2.97</b>	<b>2.82</b>	<b>2.67</b>
	Medium	30,000	<b>845-1068</b>	<b>2.68</b>	<b>2.55</b>	<b>2.41</b>
1 1/2" x 1/4" x 3/16"	Fine	20,000	<b>845-1070</b>	<b>2.68</b>	<b>2.55</b>	<b>2.41</b>
2" x 1/8" x 3/16"	Coarse	22,000	<b>845-1073</b>	<b>3.50</b>	<b>3.33</b>	<b>3.15</b>
	Medium	22,000	<b>845-1072</b>	<b>3.15</b>	<b>2.99</b>	<b>2.84</b>
2" x 1/4" x 3/16"	Fine	16,000	<b>845-1074</b>	<b>3.15</b>	<b>2.99</b>	<b>2.84</b>
Description	Item#			Each		
Mandrel for 3/16" AH wheels, 1/4" shank	<b>840-3300</b>			<b>\$32.35</b>		



## B 3M™ Scotch-Brite™ EXL Unitized Wheel Set

This 29-piece set includes 26 wheels from 1/2" to 2" in diameter (eight 1/2", six 1", six 1 1/2" and six 2" wheels) and three 1/8" shank mandrels.

Description	Item#	Each
29-Piece Set	<b>845-1054</b>	<b>\$49.60</b>

## C 3M™ Scotch-Brite™ Fiber Discs

Made of 3M Scotch-Brite nonwoven fiber material. Feature reinforced Velcro-type webbed backing for quick attachment to the unique, convenient Fiber Disc Holders (see below), which also have Velcro-type backing. Excellent for right-angle handpieces and grinders.



Dia.	Abrasive	Finishes Generated (microfinish range)		Grit	Color	Item#	Pkg. of 10
		Alum.	Steel				
1 1/2"	Aluminum oxide	56-68	16-22	Coarse	Brown	<b>108-8015</b>	<b>\$5.15</b>
	Aluminum oxide	28-37	10-16	Medium	Maroon	<b>108-8010</b>	<b>4.55</b>
	Aluminum oxide	22-28	9-12	Very fine	Blue	<b>108-8005</b>	<b>4.55</b>
	Silicon carbide	11-15	4-6	Super fine	Gray	<b>108-8000</b>	<b>4.55</b>
2"	Aluminum oxide	56-68	16-22	Coarse	Brown	<b>108-8035</b>	<b>7.35</b>
	Aluminum oxide	28-37	10-16	Medium	Maroon	<b>108-8030</b>	<b>6.50</b>
	Aluminum oxide	22-28	9-12	Very fine	Blue	<b>108-8025</b>	<b>6.50</b>
	Silicon carbide	11-15	4-6	Super fine	Gray	<b>108-8020</b>	<b>7.10</b>
3"	Aluminum oxide	56-68	16-22	Coarse	Brown	<b>108-8055</b>	<b>14.40</b>
	Aluminum oxide	28-37	10-16	Medium	Maroon	<b>108-8050</b>	<b>12.70</b>
	Aluminum oxide	22-28	9-12	Very fine	Blue	<b>108-8045</b>	<b>12.70</b>
	Silicon carbide	11-15	4-6	Super fine	Gray	<b>108-8040</b>	<b>13.85</b>



## D 3M™ Scotch-Brite™ Fiber Disc Holders – 1/4" Shank

For use with 3M Scotch-Brite Fiber Discs only (see above). All have 1/4" shank.

Holder	Item#	Each
For 1 1/2" Fiber Disc	<b>108-8060</b>	<b>\$3.30</b>
For 2" Fiber Disc	<b>108-8065</b>	<b>4.00</b>
For 3" Fiber Disc	<b>108-8070</b>	<b>4.65</b>

**A Norton® Bear-Tex® Hand Pads**

Made of loose nonwoven fiber with abrasive grain mixed throughout. Can be easily cut to desired size. For cleaning, scuffing, deburring or finishing surfaces by hand. Available in five grades. Measure approximately 6"L x 9"W x 3/8"H.

Color	Grit	Abrasive	Application	Item#	BOX of 20	
					1-2	3+
Tan	Medium	AlO	Heavy-duty cleaning	<b>108-7450</b>	<b>\$56.20</b>	<b>\$50.58</b>
Green	Very Fine	AlO	Scouring and cleaning	<b>108-7451</b>	<b>21.75</b>	<b>18.49</b>
Maroon	Very Fine	AlO	General-purpose, deburring	<b>108-7447</b>	<b>22.35</b>	<b>19.00</b>
Gray	Ultra-Fine	SiC	Light cleaning and finishing	<b>108-7448</b>	<b>22.35</b>	<b>19.00</b>



**A**

**B 3M™ Scotch-Brite™ Hand Pads**

On surfaces that require cleaning, scuffing, deburring or finishing by hand, Scotch-Brite hand pads outperform steel wool, wire brushes and other nonwoven hand pads. They cut faster and leave a more consistent finish. And Scotch-Brite pads will never rust, so they can be used with water or solvents. Available in four color-coded grades for a variety of cleaning and finishing jobs. Measure 6" x 9". Can be cut to fit Pad Holder or Mini Mandrel (see below).

Color	Application	Item#	BOX of 10	
			1-2	3+
Tan	Heavy-duty cleaning	<b>108-7461</b>	<b>\$26.50</b>	<b>\$23.85</b>
Gray	Blending and cleaning	<b>108-7459</b>	<b>17.85</b>	<b>16.07</b>

Color	Application	Item#	BOX of 20	
			1-2	3+
Maroon	Cleaning and finishing	<b>108-7457</b>	<b>\$19.70</b>	<b>\$17.73</b>
Light Gray	Fine cleaning and finishing	<b>108-7453</b>	<b>19.70</b>	<b>17.73</b>



**B**

**C 3M™ Scotch-Brite™ Pad Holder**

For use with Scotch-Brite hand pads (see above) cut to 4" x 6" size.

Description	Item#	Each
Pad Holder, 4" x 6"	<b>108-7462</b>	<b>\$17.30</b>



**C**

**D 3M™ Scotch-Brite™ Mini Mandrel – 1/4" Shank**

For use with 1" x 1 1/2" pieces of Scotch-Brite hand pads (see above). Use on contours or to reach tight areas. Acts like a flap wheel. Measures 2 7/8" long. Has 1/4" shank.

Description	Max. RPM	Item#	Each
Mini Mandrel	14,000	<b>108-7463</b>	<b>\$17.95</b>



**D**

**E Propel-Loc™ Finishing System**

**Change abrasive bands in just seconds without tools!**

With the Propel-Loc Finishing System, you slip abrasive bands on and off one drum roller instead of swapping drum arbors every time you need a different grit. Promotes efficient finishing of hard and soft metals. Consists of a lightweight, tough polyamide drum roller with teeth and aluminum oxide abrasive bands with cushioned lining. To mount a band on the roller, twist in drive direction (direction teeth point) while pushing down until seated; to remove, twist in drive direction while pulling up. Hollowed-out design of roller permits free airflow during operation, which keeps bands cool to maximize life.

Try our four-piece starter kit, which includes a 1/2" x 1/2" drum roller with 1/8" shank and three abrasive bands (60, 80 and 120 grit). Works with any rotary handpiece that accepts 1/8" shank tools. Nine-piece abrasive band assortment (three of each in 60, 80 and 120 grit) also available. Note: Only Propel-Loc abrasive bands work with drum roller; standard bands won't work.

Description	Item#	Each
<b>E. 4-Piece Starter Kit</b>	<b>101-0985</b>	<b>\$4.99</b>
9-Piece Abrasive Band Assortment	<b>101-0986</b>	<b>4.75</b>

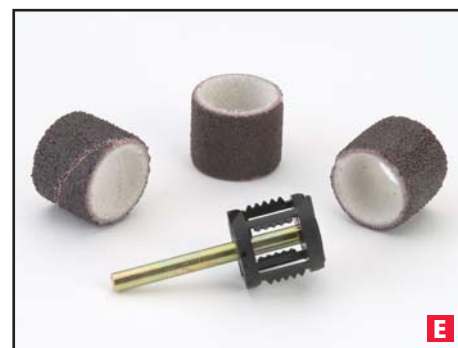

**E**

## A, B 3M™ Trizact™ Abrasive Bands

Consist of pyramid-shaped aluminum oxide particles bonded to resilient backing. Wear evenly, maintaining cut rate 2–5 times longer and producing much more uniform cuts than conventional bands. Use with Drum Arbors (see p. 68). Max. operating speed: 30,000rpm.



Dia. x H	Grit	Item#	Pkg. of 10
<b>A.</b> ¼" x ½"	200	<b>101-1001</b>	<b>\$3.15</b>
	220	<b>101-1005</b>	<b>3.15</b>
	280	<b>101-1010</b>	<b>3.15</b>
	400	<b>101-1015</b>	<b>3.15</b>
	600	<b>101-1020</b>	<b>3.15</b>
	1200	<b>101-1025</b>	<b>3.15</b>
<b>B.</b> ½" x ½"	200	<b>101-1035</b>	<b>3.60</b>
	220	<b>101-1040</b>	<b>3.60</b>
	280	<b>101-1045</b>	<b>3.60</b>
	400	<b>101-1050</b>	<b>3.60</b>
	600	<b>101-1055</b>	<b>3.60</b>
	1200	<b>101-1060</b>	<b>3.60</b>
2500	<b>101-1065</b>	<b>3.60</b>	

## C, D 3M™ Trizact™ CF Abrasive Bands

Remove roughness, parting lines, firescale and surface defects, imparting a clean, smooth finish in just one step. Cut quickly without loading. Use with Drum Arbors (see p. 68). Max. operating speed: 10,000rpm.



Dia. x H	Grit	Item#	Pkg. of 10
<b>C.</b> ½" x ½"	80	<b>101-1080</b>	<b>\$4.60</b>
	120	<b>101-1085</b>	<b>4.60</b>
	180	<b>101-1090</b>	<b>4.60</b>
	240	<b>101-1095</b>	<b>4.60</b>
	400	<b>101-1100</b>	<b>4.60</b>
<b>D.</b> ¾" x ½"	80	<b>101-1105</b>	<b>5.00</b>
	120	<b>101-1110</b>	<b>5.00</b>
	180	<b>101-1115</b>	<b>5.00</b>
	240	<b>101-1120</b>	<b>5.00</b>
400	<b>101-1125</b>	<b>5.00</b>	

## E - G 3M™ Imperial™ Micro-Finishing Film Bands and Discs

Durable, nonloading bands and discs for producing smooth, uniform finishes. Feature micron-graded aluminum oxide resin-bonded onto polyester film backing. Can be used wet or dry on soft and hard metals. To polish any metal surface to a flawless mirror shine, use Imperial Film following Flex Diamond (see p. 163), then finish with rouge. Use bands with Drum Arbors (see p. 68), discs with Mandrels for ¼" AH (see p. 66). Max. operating speed: 20,000rpm for bands; 22,000rpm for discs.



Description	Color	Grit/Micron	Item#	Pkg. of 10
<b>E.</b> ¼" x ½" Bands	Brown	180/80	<b>101-1140</b>	<b>\$6.95</b>
	Black	220/60	<b>101-1145</b>	<b>6.95</b>
	Blue	320/40	<b>101-1150</b>	<b>6.95</b>
	Green	400/30	<b>101-1155</b>	<b>6.95</b>
	Orange	600/15	<b>101-1160</b>	<b>6.95</b>
	Lt. Blue	1200/9	<b>101-1170</b>	<b>6.95</b>
<b>F.</b> ½" x ½" Bands	Brown	180/80	<b>101-1175</b>	<b>7.70</b>
	Black	220/60	<b>101-1180</b>	<b>7.70</b>
	Blue	320/40	<b>101-1185</b>	<b>7.70</b>
	Green	400/30	<b>101-1190</b>	<b>7.70</b>
	Orange	600/15	<b>101-1195</b>	<b>7.70</b>
	Lt. Blue	1200/9	<b>101-1200</b>	<b>7.70</b>
Description			Item#	Each
<b>G.</b> 51-Piece ⅞" Disc Kit (10 discs each of grits 180, 320, 400, 600, 1200, ⅜" shank mandrel, plastic case)			<b>101-1400</b>	<b>\$10.85</b>





**A - D 3M™ Aluminum Oxide Abrasive Bands**

Resin-bonded aluminum oxide abrasive bands. Provide fast, continuous cut and long-lasting performance. Can be used wet or dry. Feature closed-coat construction for fine finish and consistent cut rate. Great for curved surfaces. Use with Drum Arbors (see p. 68). Max. operating speed: 10,000rpm.

Dia. x H	Grit	Item#	Pkg. of 100
<b>A.</b> 1/4" x 1/2"	80	<b>101-0905</b>	<b>\$9.25</b>
	120	<b>101-0910</b>	<b>9.25</b>
	180	<b>101-0915</b>	<b>9.25</b>
	240	<b>101-0920</b>	<b>9.25</b>
	320	<b>101-0925</b>	<b>9.25</b>
<b>B.</b> 3/8" x 1/2"	80	<b>101-0930</b>	<b>10.45</b>
	120	<b>101-0935</b>	<b>10.45</b>
	180	<b>101-0940</b>	<b>10.45</b>
	240	<b>101-0945</b>	<b>10.45</b>
	320	<b>101-0950</b>	<b>10.45</b>
<b>C.</b> 1/2" x 1/2"	80	<b>101-0955</b>	<b>12.75</b>
	120	<b>101-0960</b>	<b>12.75</b>
	180	<b>101-0965</b>	<b>12.75</b>
	240	<b>101-0970</b>	<b>12.75</b>
	320	<b>101-0975</b>	<b>12.75</b>
Description		Item#	Each
<b>D.</b> 21-Piece 3/8" x 1/2" Intro Kit (five bands each of grits 120, 180, 240, 320, 3/32" shank drum arbor, plastic case)		<b>101-0976</b>	<b>\$10.45</b>
	21-Piece 1/2" x 1/2" Intro Kit (five bands each of grits 120, 180, 240, 320, 3/32" shank drum arbor, plastic case)	<b>101-0977</b>	<b>10.45</b>

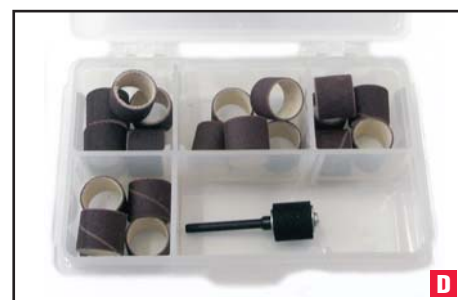

**E - I Abrasive Bands**

Long-lasting resin-bonded aluminum oxide bands with cloth backing. Provide chatter-free operation for grinding, blending, deburring, smoothing, finishing and polishing flat and contoured metal surfaces, including the insides of holes. Use with Drum Arbors (see p. 68). Max. operating speed: 30,000rpm.

Dia. x H	Grit	Item#	Box of 100
<b>E.</b> 1/4" x 1/2"	80	<b>101-0208</b>	<b>\$8.35</b>
	120	<b>101-0212</b>	<b>8.35</b>
	180	<b>101-0218</b>	<b>8.35</b>
	240	<b>101-0224</b>	<b>8.35</b>
	320	<b>101-0232</b>	<b>8.35</b>
<b>F.</b> 3/8" x 1/2"	60	<b>101-0306</b>	<b>9.45</b>
	80	<b>101-0308</b>	<b>9.45</b>
	120	<b>101-0312</b>	<b>9.45</b>
	180	<b>101-0318</b>	<b>9.45</b>
	240	<b>101-0324</b>	<b>9.45</b>
<b>G.</b> 1/2" x 1/2"	80	<b>101-0408</b>	<b>11.50</b>
	120	<b>101-0412</b>	<b>11.50</b>
	180	<b>101-0418</b>	<b>11.50</b>
	240	<b>101-0424</b>	<b>11.50</b>
	320	<b>101-0432</b>	<b>11.50</b>
<b>H.</b> 3/4" x 1"	80	<b>101-0708</b>	<b>12.25</b>
	120	<b>101-0712</b>	<b>12.25</b>
	240	<b>101-0724</b>	<b>12.25</b>
Description		Item#	Each
<b>I.</b> 44-Piece 1/2" x 1/2" Intro Kit (10 bands each of grits 120, 180, 240, 320, four 3/32" shank drum arbors, plastic case)		<b>101-0440</b>	<b>\$25.95</b>
	44-Piece 1/2" x 1/2" Intro Kit (10 bands each of grits 120, 180, 240, 320, four 1/8" shank drum arbors, plastic case)	<b>101-0445</b>	<b>25.95</b>



## A - C 3M™ Cubitron™ Ceramic Bands

Cubitron ceramic aluminum oxide is simply the best, toughest mineral on the market. Cuts like conventional aluminum oxide but lasts twice as long and produces much less dust. Cubitron bands provide a great finish. Use with Drum Arbors (see p. 68). Max. operating speed: 20,000rpm.



	Dia. x H	Grit	Item#	Pkg of 10	Item#	Pkg of 100
<b>A.</b>	1/4" x 1/2"	80	<b>101-1239</b>	<b>\$3.05</b>	<b>101-1240</b>	<b>\$16.30</b>
		120	<b>101-1237</b>	<b>3.05</b>	<b>101-1245</b>	<b>16.30</b>
		220	<b>101-1242</b>	<b>3.05</b>	<b>101-1250</b>	<b>16.30</b>
<b>B.</b>	1/2" x 1/2"	80	<b>101-1252</b>	<b>4.15</b>	<b>101-1260</b>	<b>22.60</b>
		120	<b>101-1262</b>	<b>4.15</b>	<b>101-1265</b>	<b>22.60</b>
		220	<b>101-1267</b>	<b>4.15</b>	<b>101-1270</b>	<b>22.60</b>
<b>C.</b>	3/4" x 1/2"	80	<b>101-1277</b>	<b>5.05</b>	<b>101-1280</b>	<b>24.95</b>
		120	<b>101-1282</b>	<b>5.05</b>	<b>101-1285</b>	<b>24.95</b>
		220	<b>101-1287</b>	<b>5.05</b>	<b>101-1290</b>	<b>24.95</b>

## D - F 3M™ Flex Diamond Bands and Discs

Incredibly durable, nonloading bands and discs for cleaning, shaping and precision pre-finishing. Coated with micron-graded diamond abrasive in a honeycomb pattern for fast cutting. Can be used wet or dry on both soft and hard metals. Produce optimal finishes with minimal metal removal. Won't gouge or catch. To polish any metal surface to a flawless mirror shine, use Flex Diamond prior to Imperial Film (see p. 66), then finish with rouge. Use bands with Drum Arbors (see p. 68), discs with Mandrels for 1/16" AH (see p. 131). Max. operating speed: 20,000rpm for bands; 22,000rpm for discs.



Description	Grit	Item#	Each
<b>D.</b> 1/4" x 1/2" Band	120	<b>101-1310</b>	<b>\$3.35</b>
	220	<b>101-1315</b>	<b>3.35</b>
	400	<b>101-1320</b>	<b>2.95</b>
	800	<b>101-1325</b>	<b>2.95</b>
<b>E.</b> 1/2" x 1/2" Band	60	<b>101-1330</b>	<b>4.95</b>
	120	<b>101-1335</b>	<b>4.65</b>
	220	<b>101-1340</b>	<b>4.05</b>
	400	<b>101-1345</b>	<b>3.90</b>
	800	<b>101-1350</b>	<b>3.90</b>
Description	Item#	Each	
6-Piece 1/2" x 1/2" Band Kit (one band each of grits 60, 120, 220, 400, 800, 3/32" shank drum arbor, plastic case)	<b>101-1355</b>	<b>\$21.95</b>	
<b>F.</b> 26-Piece 7/8" Disc Kit (five discs each of grits 60, 120, 220, 400, 800, 3/32" shank mandrel, plastic case)	<b>101-1360</b>	<b>47.50</b>	

## G - K Abrasive Band Drum Arbors

Steel Drum Arbors have solid rubber drums that expand to hold Abrasive Bands snugly. The rubber drum provides a cushioned backing so that Abrasive Bands cut smoothly and leave a uniform finish. Balanced for maximum performance at high speeds.

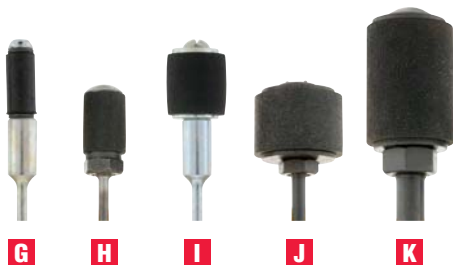

Dia. x H	Shank	Item#	EACH Prices		
			1-2	3-11	12+
<b>G.</b> 1/4" x 1/2"	3/32"	<b>840-1045</b>	<b>\$3.35</b>	<b>\$3.18</b>	<b>\$2.85</b>
	1/8"	<b>840-1050</b>	<b>3.35</b>	<b>3.18</b>	<b>2.85</b>
<b>H.</b> 3/8" x 1/2"	3/32"	<b>840-1035</b>	<b>3.35</b>	<b>3.18</b>	<b>2.85</b>
	1/8"	<b>840-1040</b>	<b>3.35</b>	<b>3.18</b>	<b>2.85</b>
<b>I.</b> 1/2" x 1/2"	3/32"	<b>840-1055</b>	<b>3.35</b>	<b>3.18</b>	<b>2.85</b>
	1/8"	<b>840-1060</b>	<b>3.35</b>	<b>3.18</b>	<b>2.85</b>
	1/4"	<b>840-1170</b>	<b>3.35</b>	<b>3.18</b>	<b>2.85</b>
<b>J.</b> 3/4" x 1/2"	1/8"	<b>840-1030</b>	<b>3.35</b>	<b>3.18</b>	<b>2.85</b>
	1/4"	<b>840-1200</b>	<b>4.35</b>	<b>4.13</b>	<b>3.70</b>
<b>K.</b> 3/4" x 1"	1/4"	<b>840-1120</b>	<b>4.35</b>	<b>4.13</b>	<b>3.70</b>

**A - C Seamless Abrasive Caps and Holders – 1/8" and 1/4" Shanks**

Use for deburring and finishing hard-to-reach, recessed areas. Designed for easy mounting and removal. Caps fit holders easily yet are held firmly by centrifugal force while working. Holders have 1/8" or 1/4" shanks (3mm and 6mm shanks available by special order).

Cap	Dia. x H	Max. RPM	Grit	Item#	Pkg. of 50	Holder	Item#	Each
<b>A. Flat</b>	3/16" x 3/8"	40,000	80	<b>104-1000</b>	<b>\$27.95</b>	1/8" shank	<b>104-1200</b>	<b>\$2.95</b>
			150	<b>104-1005</b>	<b>27.95</b>		<b>104-1200</b>	<b>2.95</b>
			280	<b>104-1010</b>	<b>27.95</b>		<b>104-1200</b>	<b>2.95</b>
	9/32" x 1/2"	30,000	60	<b>104-1015</b>	<b>27.95</b>	1/4" shank	<b>104-1205</b>	<b>2.95</b>
			150	<b>104-1020</b>	<b>27.95</b>		<b>104-1205</b>	<b>2.95</b>
			280	<b>104-1025</b>	<b>27.95</b>		<b>104-1205</b>	<b>2.95</b>
	3/8" x 5/8"	20,000	60	<b>104-1030</b>	<b>32.85</b>	1/4" shank	<b>104-1210</b>	<b>2.95</b>
			150	<b>104-1035</b>	<b>32.85</b>		<b>104-1210</b>	<b>2.95</b>
			280	<b>104-1040</b>	<b>32.85</b>		<b>104-1210</b>	<b>2.95</b>
	1/2" x 1 1/16"	16,000	60	<b>104-1260</b>	<b>38.25</b>	1/4" shank	<b>104-1350</b>	<b>3.25</b>
			150	<b>104-1265</b>	<b>38.25</b>		<b>104-1350</b>	<b>3.25</b>
			280	<b>104-1270</b>	<b>38.25</b>		<b>104-1350</b>	<b>3.25</b>
	5/8" x 1"	12,000	60	<b>104-1275</b>	<b>38.25</b>	1/4" shank	<b>104-1355</b>	<b>3.25</b>
			150	<b>104-1280</b>	<b>38.25</b>		<b>104-1355</b>	<b>3.25</b>
			280	<b>104-1285</b>	<b>38.25</b>		<b>104-1355</b>	<b>3.25</b>
<b>B. Rd.</b>	3/16" x 7/16"	40,000	80	<b>104-1045</b>	<b>27.95</b>	1/8" shank	<b>104-1215</b>	<b>2.95</b>
			150	<b>104-1050</b>	<b>27.95</b>		<b>104-1215</b>	<b>2.95</b>
			280	<b>104-1055</b>	<b>27.95</b>		<b>104-1215</b>	<b>2.95</b>
	9/32" x 1/2"	30,000	60	<b>104-1060</b>	<b>27.95</b>	1/4" shank	<b>104-1220</b>	<b>2.95</b>
			150	<b>104-1065</b>	<b>27.95</b>		<b>104-1220</b>	<b>2.95</b>
			280	<b>104-1070</b>	<b>27.95</b>		<b>104-1220</b>	<b>2.95</b>
	3/8" x 5/8"	20,000	60	<b>104-1075</b>	<b>32.85</b>	1/4" shank	<b>104-1225</b>	<b>2.95</b>
			150	<b>104-1080</b>	<b>32.85</b>		<b>104-1225</b>	<b>2.95</b>
			280	<b>104-1085</b>	<b>32.85</b>		<b>104-1225</b>	<b>2.95</b>
	1/2" x 1 1/16"	16,000	60	<b>104-1290</b>	<b>38.25</b>	1/4" shank	<b>104-1360</b>	<b>3.25</b>
			150	<b>104-1295</b>	<b>38.25</b>		<b>104-1360</b>	<b>3.25</b>
			280	<b>104-1300</b>	<b>38.25</b>		<b>104-1360</b>	<b>3.25</b>
	5/8" x 1"	12,000	60	<b>104-1305</b>	<b>38.25</b>	1/4" shank	<b>104-1365</b>	<b>3.25</b>
			150	<b>104-1310</b>	<b>38.25</b>		<b>104-1365</b>	<b>3.25</b>
			280	<b>104-1315</b>	<b>38.25</b>		<b>104-1365</b>	<b>3.25</b>
<b>C. Cone</b>	3/16" x 7/16"	40,000	80	<b>104-1090</b>	<b>27.95</b>	1/8" shank	<b>104-1230</b>	<b>2.95</b>
			150	<b>104-1095</b>	<b>27.95</b>		<b>104-1230</b>	<b>2.95</b>
			280	<b>104-1100</b>	<b>27.95</b>		<b>104-1230</b>	<b>2.95</b>
	9/32" x 1/2"	30,000	60	<b>104-1105</b>	<b>27.95</b>	1/4" shank	<b>104-1235</b>	<b>2.95</b>
			150	<b>104-1110</b>	<b>27.95</b>		<b>104-1235</b>	<b>2.95</b>
			280	<b>104-1115</b>	<b>27.95</b>		<b>104-1235</b>	<b>2.95</b>
	3/8" x 5/8"	20,000	60	<b>104-1120</b>	<b>32.85</b>	1/4" shank	<b>104-1240</b>	<b>2.95</b>
			150	<b>104-1125</b>	<b>32.85</b>		<b>104-1240</b>	<b>2.95</b>
			280	<b>104-1130</b>	<b>32.85</b>		<b>104-1240</b>	<b>2.95</b>
	1/2" x 1 1/16"	16,000	60	<b>104-1320</b>	<b>38.25</b>	1/4" shank	<b>104-1370</b>	<b>3.25</b>
			150	<b>104-1325</b>	<b>38.25</b>		<b>104-1370</b>	<b>3.25</b>
			280	<b>104-1330</b>	<b>38.25</b>		<b>104-1370</b>	<b>3.25</b>
	5/8" x 1"	12,000	60	<b>104-1335</b>	<b>38.25</b>	1/4" shank	<b>104-1375</b>	<b>3.25</b>
			150	<b>104-1340</b>	<b>38.25</b>		<b>104-1375</b>	<b>3.25</b>
			280	<b>104-1345</b>	<b>38.25</b>		<b>104-1375</b>	<b>3.25</b>



**D Seamless Abrasive Cap Set**

This money-saving set includes 270 caps (six of each item# listed in chart above) and 15 corresponding holders (1/8" and 1/4" shanks). Supplied in a convenient 16-compartment plastic storage tray with lid.

Description	Item#	Each
Seamless Abrasive Cap Set	<b>104-1245</b>	<b>\$219.00</b>

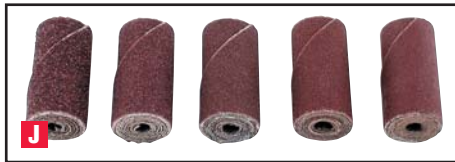
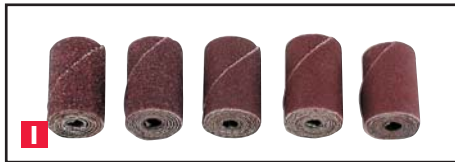
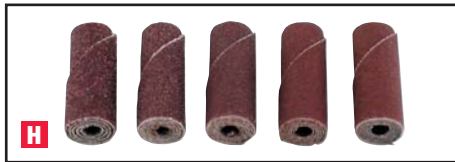

## A - K Straight Abrasive Cartridge Rolls

Resin-bonded aluminum oxide cloth rolls for lapping surfaces and finishing inside diameters. Self-renewing: wearing through one layer uncovers fresh layer. Balanced to eliminate wobble. Use with cartridge roll mandrels (see p. 71). Max. operating speed: 16,000–22,000rpm.

Dia. x L x AH	Use Mandrel	Grit	Item#	BOX of 100	
				1-2	3+
A. 1/8" x 3/4" x 5/64"	A1	80	<b>103-1208</b>	<b>\$28.50</b>	<b>\$27.08</b>
		120	<b>103-1212</b>	<b>28.50</b>	<b>27.08</b>
		180	<b>103-1218</b>	<b>28.50</b>	<b>27.08</b>
		240	<b>103-1224</b>	<b>28.50</b>	<b>27.08</b>
		320	<b>103-1232</b>	<b>28.50</b>	<b>27.08</b>
B. 1/8" x 1" x 5/64"	A1	80	<b>103-1308</b>	<b>28.50</b>	<b>27.08</b>
		120	<b>103-1312</b>	<b>28.50</b>	<b>27.08</b>
		180	<b>103-1318</b>	<b>28.50</b>	<b>27.08</b>
		240	<b>103-1324</b>	<b>28.50</b>	<b>27.08</b>
		320	<b>103-1332</b>	<b>28.50</b>	<b>27.08</b>
C. 3/16" x 3/4" x 3/32"	A2	120	<b>103-2212</b>	<b>22.95</b>	<b>21.80</b>
		180	<b>103-2218</b>	<b>22.95</b>	<b>21.80</b>
		240	<b>103-2224</b>	<b>22.95</b>	<b>21.80</b>
		320	<b>103-2232</b>	<b>22.95</b>	<b>21.80</b>
		D. 3/16" x 1" x 3/32"	A2	80	<b>103-2308</b>
120	<b>103-2312</b>			<b>23.95</b>	<b>22.75</b>
180	<b>103-2318</b>			<b>23.95</b>	<b>22.75</b>
240	<b>103-2324</b>			<b>23.95</b>	<b>22.75</b>
320	<b>103-2332</b>			<b>23.95</b>	<b>22.75</b>
E. 1/4" x 3/4" x 1/8"	A4 or A8	80	<b>103-3208</b>	<b>22.95</b>	<b>21.80</b>
		120	<b>103-3212</b>	<b>22.95</b>	<b>21.80</b>
		180	<b>103-3218</b>	<b>22.95</b>	<b>21.80</b>
		240	<b>103-3224</b>	<b>22.95</b>	<b>21.80</b>
		320	<b>103-3232</b>	<b>22.95</b>	<b>21.80</b>
F. 1/4" x 1" x 1/8"	A5 or A9	80	<b>103-3308</b>	<b>23.95</b>	<b>22.75</b>
		120	<b>103-3312</b>	<b>23.95</b>	<b>22.75</b>
		180	<b>103-3318</b>	<b>23.95</b>	<b>22.75</b>
		240	<b>103-3324</b>	<b>23.95</b>	<b>22.75</b>
		320	<b>103-3332</b>	<b>23.95</b>	<b>22.75</b>
G. 3/8" x 3/4" x 1/8"	A4 or A8	80	<b>103-5208</b>	<b>23.95</b>	<b>22.75</b>
		120	<b>103-5212</b>	<b>23.95</b>	<b>22.75</b>
		180	<b>103-5218</b>	<b>23.95</b>	<b>22.75</b>
		240	<b>103-5224</b>	<b>23.95</b>	<b>22.75</b>
		320	<b>103-5232</b>	<b>23.95</b>	<b>22.75</b>
H. 3/8" x 1" x 1/8"	A5 or A9	80	<b>103-5308</b>	<b>25.50</b>	<b>24.23</b>
		120	<b>103-5312</b>	<b>25.50</b>	<b>24.23</b>
		180	<b>103-5318</b>	<b>25.50</b>	<b>24.23</b>
		240	<b>103-5324</b>	<b>25.50</b>	<b>24.23</b>
		320	<b>103-5332</b>	<b>25.50</b>	<b>24.23</b>
I. 1/2" x 3/4" x 1/8"	A4 or A8	80	<b>103-6208</b>	<b>25.50</b>	<b>24.23</b>
		120	<b>103-6212</b>	<b>25.50</b>	<b>24.23</b>
		180	<b>103-6218</b>	<b>25.50</b>	<b>24.23</b>
		240	<b>103-6224</b>	<b>25.50</b>	<b>24.23</b>
		320	<b>103-6232</b>	<b>25.50</b>	<b>24.23</b>
J. 1/2" x 1" x 1/8"	A5 or A9	80	<b>103-6308</b>	<b>29.25</b>	<b>27.79</b>
		120	<b>103-6312</b>	<b>29.25</b>	<b>27.79</b>
		180	<b>103-6318</b>	<b>29.25</b>	<b>27.79</b>
		240	<b>103-6324</b>	<b>29.25</b>	<b>27.79</b>
		320	<b>103-6332</b>	<b>29.25</b>	<b>27.79</b>
K. 1/2" x 1 1/2" x 1/8"	A6 or A10	80	<b>103-6340</b>	<b>43.50</b>	<b>41.33</b>
		120	<b>103-6345</b>	<b>43.50</b>	<b>41.33</b>
		320	<b>103-6360</b>	<b>43.50</b>	<b>41.33</b>



**A, B Abrasive Tapered Cartridge Rolls**

Made of resin-bonded aluminum oxide cloth. Particularly useful on jobs with channels, fillets and irregular concave contours. Hold at a 45° angle to workpiece for reaching into angles and corners, or hold at a lower angle to apply greater abrasive surface for faster cutting action. Self-renewing: wearing through one layer uncovers fresh layer. Balanced to eliminate wobble. Use with cartridge roll mandrels (see below). Max. operating speed: 16,000–22,000rpm.

Dia. x L x AH	Use Mandrel	Grit	Item#	BOX of 100	
				1-2	3+
<b>A.</b> 3/8" x 1 1/2" x 1/8"	A6 or A10	80	<b>103-7001</b>	<b>\$53.50</b>	<b>\$50.83</b>
		120	<b>103-7002</b>	<b>53.50</b>	<b>50.83</b>
		180	<b>103-7003</b>	<b>55.50</b>	<b>52.73</b>
		240	<b>103-7004</b>	<b>55.50</b>	<b>52.73</b>
<b>B.</b> 1/2" x 1 1/2" x 1/8"	A6 or A10	80	<b>103-7007</b>	<b>57.95</b>	<b>55.05</b>
		120	<b>103-7008</b>	<b>57.95</b>	<b>55.05</b>



**C, D 3M™ Aluminum Oxide Cartridge Rolls**

High-quality aluminum oxide sandpaper rolls tightly wrapped and resin-bonded together. As each layer wears out, it can be peeled away to reveal a fresh surface. Can be used wet or dry. Use with cartridge roll mandrels (see below). Max. operating speed: 15,000rpm.

Dia. x L	Use Mandrel	Grit	Item#	PKG. of 100	
				1-2	3+
<b>C.</b> 1/2" x 3/4"	A4	120	<b>101-0150</b>	<b>\$20.95</b>	<b>\$17.81</b>
		180	<b>101-0151</b>	<b>20.95</b>	<b>17.81</b>
		240	<b>101-0152</b>	<b>20.95</b>	<b>17.81</b>
		320	<b>101-0153</b>	<b>20.95</b>	<b>17.81</b>



Description	Item#	Each
-------------	-------	------

<b>D.</b> 17-Piece Intro Kit (four rolls of each grit, 1/8" shank mandrel and plastic case)	<b>101-0154</b>	<b>\$10.50</b>
---	-----------------	----------------

**E Cartridge Roll Mandrels – 1/8" and 1/4" Shanks**

Hardened steel mandrels firmly secure straight or tapered abrasive cartridge rolls. More flexibility may be obtained if pilot length is slightly shorter than the cartridge rolls. If necessary, mandrels may be ground down to needed length. Available on 1/4" or 1/8" shanks.

Mandrel	Pilot Size	Shank	Item#	EACH Prices		
				1-2	3-11	12+
A1	5/64" x 1"	1/8"	<b>840-2040</b>	<b>\$2.95</b>	<b>\$2.80</b>	<b>\$2.66</b>
A2	3/32" x 1"	1/8"	<b>840-2050</b>	<b>2.95</b>	<b>2.80</b>	<b>2.66</b>
A3	1/8" x 1/2"	1/8"	<b>840-2060</b>	<b>2.95</b>	<b>2.80</b>	<b>2.66</b>
A4	1/8" x 3/4"	1/8"	<b>840-2070</b>	<b>2.95</b>	<b>2.80</b>	<b>2.66</b>
A5	1/8" x 1"	1/8"	<b>840-2080</b>	<b>3.25</b>	<b>3.09</b>	<b>2.93</b>
A6	1/8" x 1 1/2"	1/8"	<b>840-2090</b>	<b>3.25</b>	<b>3.09</b>	<b>2.93</b>
A7	1/8" x 1/2"	1/4"	<b>840-2120</b>	<b>3.25</b>	<b>3.09</b>	<b>2.93</b>
A8	1/8" x 3/4"	1/4"	<b>840-2130</b>	<b>3.25</b>	<b>3.09</b>	<b>2.93</b>
A9	1/8" x 1"	1/4"	<b>840-2140</b>	<b>3.25</b>	<b>3.09</b>	<b>2.93</b>
A10	1/8" x 1 1/2"	1/4"	<b>840-2150</b>	<b>3.25</b>	<b>3.09</b>	<b>2.93</b>
A11	1/8" x 2"	1/4"	<b>840-2160</b>	<b>3.25</b>	<b>3.09</b>	<b>2.93</b>



**F Premounted Abrasive Rolls – 3/32" Shank**

Each roll consists of aluminum oxide abrasive paper wrapped around a 3/32" shank mandrel, creating many layers. Since paper is secured only at the bottom, user can easily tear off worn portion to expose fresh cutting surface. Unlike regular unmounted rolls, these long-lasting rolls require no truing.

Grit	Dia. x H	Max. RPM	Item#	EACH Prices	
				1-9	10+
240	1/2" x 1 1/8"	22,000	<b>103-7110</b>	<b>\$1.95</b>	<b>\$1.56</b>
320	1/2" x 1 1/8"	22,000	<b>103-7112</b>	<b>1.95</b>	<b>1.56</b>
400	1/2" x 1 1/8"	22,000	<b>103-7114</b>	<b>1.95</b>	<b>1.56</b>
600	1/2" x 1 1/8"	22,000	<b>103-7116</b>	<b>1.95</b>	<b>1.56</b>
800	1/2" x 1 1/8"	22,000	<b>103-7118</b>	<b>1.95</b>	<b>1.56</b>



## A Tapered Cone Points

Glue-bonded aluminum oxide points for finishing, deburring and polishing applications. All slightly longer than specified. Max. operating speed: 25,000rpm.



**A**

Style	Dia. x L	Grit	Item#	Box of 100
<b>A. K11 (2½° Taper)</b>	⅜" x 1"	60	<b>107-1100</b>	<b>\$33.45</b>
		80	<b>107-1150</b>	<b>33.45</b>
		100	<b>107-1200</b>	<b>33.45</b>
		120	<b>107-1250</b>	<b>33.45</b>
		180	<b>107-1350</b>	<b>33.45</b>
		240	<b>107-1400</b>	<b>33.45</b>
		320	<b>107-1450</b>	<b>33.45</b>
<b>B2 (5° Taper)</b>	⅝" x 1½"	60	<b>107-0100</b>	<b>32.35</b>
		80	<b>107-0150</b>	<b>32.35</b>
		100	<b>107-0200</b>	<b>32.35</b>
		120	<b>107-0250</b>	<b>32.35</b>
		180	<b>107-0350</b>	<b>32.35</b>
		240	<b>107-0400</b>	<b>32.35</b>
<b>C3 (5° Taper)</b>	¾" x 2"	80	<b>107-0650</b>	<b>37.19</b>
		120	<b>107-0750</b>	<b>37.19</b>
		320	<b>107-0950</b>	<b>37.19</b>

**B**

**C**

**D**

## B - D Tapered Cone Point Mandrels

For use with Tapered Cone Points (see above).

For Point Style	Shank	Item#	Each
<b>B. K11</b>	⅛"	<b>840-2030</b>	<b>\$4.45</b>
<b>C. B2</b>	¼"	<b>840-2010</b>	<b>5.45</b>
<b>D. C3</b>	¼"	<b>840-2020</b>	<b>6.50</b>

## E - G Paper Bullets and Cones

Economical paper bullets and cones for fine finishing in hard-to-reach areas. Cones expose new grit as they wear. Recommended or use at low speeds for better control and longer life. Designed for fast, easy changing. Use bullets and small cones with threaded mandrel (see below), large cones with split mandrel (see below).

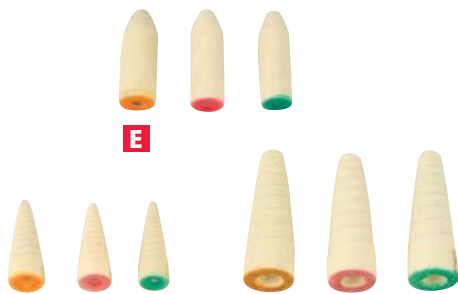

**E**

**F**

**G**

Shape	Dia. x L	Color	Grit	Item#	Pkg. of 10
<b>E. Bullet</b>	¼" x ⅝"	Yellow	Coarse	<b>107-1058</b>	<b>\$5.45</b>
		Red	Medium	<b>107-1057</b>	<b>5.45</b>
		Green	Fine	<b>107-1056</b>	<b>5.45</b>
<b>F. Small Cone</b>	¼" x ⅞"	Yellow	Coarse	<b>107-1055</b>	<b>5.45</b>
		Red	Medium	<b>107-1054</b>	<b>5.45</b>
		Green	Fine	<b>107-1053</b>	<b>5.45</b>
<b>G. Large Cone</b>	⅝" x 1⅝"	Yellow	Coarse	<b>107-1052</b>	<b>4.95</b>
		Red	Medium	<b>107-1051</b>	<b>4.95</b>
		Green	Fine	<b>107-1050</b>	<b>4.95</b>

**H**

**I**

## H, I Paper Bullet and Cone Mandrels - ⅜" Shanks

Use threaded with bullets and small cones (see above), split with large cones (see above).

Description	Shank	Item#	Each
<b>H. Threaded Mandrel</b>	⅜"	<b>840-3040</b>	<b>\$0.85</b>
<b>I. Split Mandrel</b>	⅜"	<b>840-3407</b>	<b>2.40</b>

## J Paper Cone Set

Perfect for fine finishing in tight areas. Includes 10 yellow (coarse), 10 red (medium) and 10 green (fine) large cones; 10 yellow, 10 red and 10 green small cones; split mandrel for large cones, ⅜" shank; and threaded mandrel for small cones, ⅜" shank. Cones expose new grit as they wear. Recommended for use at low speeds for better control and longer life. Designed for fast, easy changing.

Description	Item#	Each
Paper Cone Set	<b>107-1060</b>	<b>\$32.95</b>



**J**

**A - E PSA Discs**

These flexible discs are made of aluminum oxide resin-bonded for greater durability. Pressure-sensitive adhesive backing withstands the high frictional heat generated when a disc is in use. PSA Discs will stay on until removed from the holder by hand. Each disc has a peel-off backing to ensure adhesive freshness.

Dia.	Grit	Item#	Box of 100
<b>A. 1/2"</b>	60	<b>105-0506</b>	<b>\$6.95</b>
	80	<b>105-0508</b>	<b>6.95</b>
	100	<b>105-0510</b>	<b>6.95</b>
	120	<b>105-0512</b>	<b>6.95</b>
	180	<b>105-0518</b>	<b>6.95</b>
	240	<b>105-0524</b>	<b>6.95</b>
<b>B. 3/4"</b>	60	<b>105-0706</b>	<b>7.95</b>
	80	<b>105-0708</b>	<b>7.95</b>
	100	<b>105-0710</b>	<b>7.95</b>
	120	<b>105-0712</b>	<b>7.95</b>
	180	<b>105-0718</b>	<b>7.95</b>
	240	<b>105-0724</b>	<b>7.95</b>
<b>C. 1"</b>	60	<b>105-1006</b>	<b>13.25</b>
	80	<b>105-1008</b>	<b>13.25</b>
	100	<b>105-1010</b>	<b>13.25</b>
	120	<b>105-1012</b>	<b>13.25</b>
	180	<b>105-1018</b>	<b>13.25</b>
	240	<b>105-1024</b>	<b>13.25</b>
<b>D. 1 1/2"</b>	60	<b>105-1506</b>	<b>16.50</b>
	80	<b>105-1508</b>	<b>16.50</b>
	100	<b>105-1510</b>	<b>16.50</b>
	120	<b>105-1512</b>	<b>16.50</b>
	180	<b>105-1518</b>	<b>16.50</b>
	240	<b>105-1524</b>	<b>16.50</b>
<b>E. 2"</b>	60	<b>105-2006</b>	<b>25.95</b>
	80	<b>105-2008</b>	<b>25.95</b>
	100	<b>105-2010</b>	<b>25.95</b>
	120	<b>105-2012</b>	<b>25.95</b>
	180	<b>105-2018</b>	<b>25.95</b>
	240	<b>105-2024</b>	<b>25.95</b>
	320	<b>105-2032</b>	<b>25.95</b>
	400	<b>105-2040</b>	<b>25.95</b>

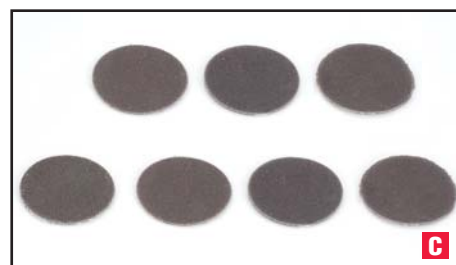
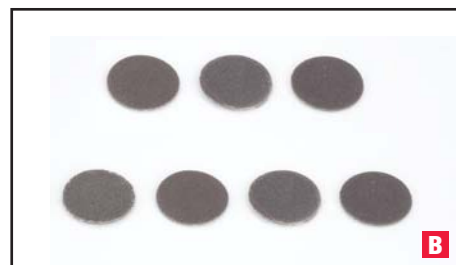
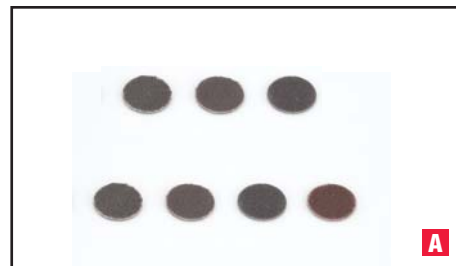

**F - J PSA Disc Holders – 1/8" and 1/4" Shanks**

Flexible rubber pads mounted on shanks to hold PSA Discs. Actual pad diameters are slightly smaller than specified to ensure easy removal of discs and to prevent material from marring the work surface. Max. operating speed: 22,000rpm.

Shank	Head Dia.	Item#	EACH Prices	
			1-2	3+
1/8"	1/2"	<b>840-0010</b>	<b>\$3.50</b>	<b>\$2.92</b>
	3/4"	<b>840-0030</b>	<b>3.85</b>	<b>3.21</b>
	1"	<b>840-0050</b>	<b>3.95</b>	<b>3.29</b>
	1 1/2"	<b>840-0070</b>	<b>4.95</b>	<b>4.12</b>
1/4"	1/2"	<b>840-0020</b>	<b>3.50</b>	<b>2.92</b>
	3/4"	<b>840-0040</b>	<b>3.85</b>	<b>3.21</b>
<b>H.</b>	1"	<b>840-0060</b>	<b>3.95</b>	<b>3.29</b>
<b>I.</b>	1 1/2"	<b>840-0080</b>	<b>4.95</b>	<b>4.12</b>
<b>J.</b>	2"	<b>840-0090</b>	<b>5.75</b>	<b>4.79</b>





## A - H Snap-On Discs and Mandrel

Snap-On Discs feature quick-change, sure-lock brass centers. Two types of paper-backed discs are available: Emery contain black silicon carbide, a fast-cutting abrasive; Adalox contain aluminum oxide, less aggressive than Emery. Three types of plastic-backed discs are available: Sand contain long-lasting white aluminum oxide; AlO, the longest-lasting of the bunch, contain evenly dispersed micron-grade aluminum oxide, which provides smooth, fast cutting action; Felt can be charged with compound or paste for quick and easy finishing (contain no abrasive). Max. operating speed: 30,000rpm. Use with Snap-On Mandrel (see below).

Type/Backing	Dia.	Coarse Grit	Med. Grit	Fine Grit	BOX of 50		
		Item#	Item#	Item#	1-5	6-11*	12+*
A. Emery/Paper	3/4"	<b>845-2585</b>	<b>845-2590</b>	<b>845-2595</b>	<b>\$2.95</b>	<b>\$2.66</b>	<b>\$2.51</b>
B.	7/8"	<b>845-2596</b>	<b>845-2597</b>	<b>845-2598</b>	<b>2.95</b>	<b>2.66</b>	<b>2.51</b>
C. Adalox/Paper	3/4"	<b>845-2600</b>	<b>845-2650</b>	<b>845-2700</b>	<b>3.95</b>	<b>3.56</b>	<b>3.36</b>
D.	7/8"	<b>845-2715</b>	<b>845-2710</b>	<b>845-2705</b>	<b>3.95</b>	<b>3.56</b>	<b>3.36</b>
E. Sand/Plastic	3/4"	<b>845-2858</b>	<b>845-2857</b>	<b>845-2856</b>	<b>4.95</b>	<b>4.46</b>	<b>4.21</b>
	7/8"	<b>845-2865</b>	<b>845-2863</b>	<b>845-2860</b>	<b>4.95</b>	<b>4.46</b>	<b>4.21</b>

Type/Backing	Dia.	Coarse Grit	Med. Grit	BOX of 100	
		Item#	Item#	1-11	12+*
F. AlO/Plastic	7/8"	<b>845-2900</b>	<b>845-2902</b>	<b>\$11.95</b>	<b>\$10.16</b>

Type/Backing	Dia.	Item#		BOX of 100	
				1-11	12+
G. Felt/Plastic	7/8"	<b>845-0970</b>		<b>\$23.95</b>	<b>\$21.56</b>

Description	Item#	EACH Prices	
		1-11	12+
H. Snap-On Mandrel, 3/32" shank	<b>840-3200</b>	<b>\$1.75</b>	<b>\$1.46</b>

\*Qty. discount for orders of one item# only, not assorted.

## I Snap-On Disc Set

Includes 120 Snap-On Discs (10 of each grit, 7/8" dia.), two Snap-On Mandrels and storage box.

Description	Item#	Each
120-Piece Set, 7/8" dia.	<b>845-2905</b>	<b>\$14.80</b>



J



K



L



M

N

## J - M Mitchell's Abrasive Cords and Tapes

Flexible cords and tapes fully covered in abrasives for grinding, polishing and finishing small holes, narrow slots, curved surfaces and other areas standard tools can't reach. Aluminum oxide and silicon carbide are for cutting, and crocus (ultra-fine iron oxide) is for especially fine polishing. Can be used by hand and in sawframes, drills and other tools on hard and soft metals, ceramic, plastic and wood. Won't tear or fray. Supplied in 50' spools.

Cord ●	Style	Dia.	Grit	Item#	50' Spool
J. AlO	49	.082"	120	<b>102-1000</b>	<b>\$18.15</b>
	50	.070"	180	<b>102-1005</b>	<b>18.15</b>
	51	.055"	120	<b>102-1010</b>	<b>10.40</b>
	53	.040"	180	<b>102-1020</b>	<b>10.75</b>
	54	.030"	200	<b>102-1025</b>	<b>10.75</b>
K. SiC	54-H	.025"	200	<b>102-1030</b>	<b>10.75</b>
	55	.018"	200	<b>102-1035</b>	<b>11.85</b>
	60	.015"	200	<b>102-1040</b>	<b>11.85</b>
	66	.012"	280	<b>102-1045</b>	<b>28.65</b>
L. Crocus	52-C	.055"	Ultra-fine	<b>102-1060</b>	<b>12.40</b>
	53-C	.040"	Ultra-fine	<b>102-1065</b>	<b>12.40</b>
	54-C	.030"	Ultra-fine	<b>102-1070</b>	<b>12.40</b>
	54-HC	.025"	Ultra-fine	<b>102-1075</b>	<b>13.70</b>
	55-C	.018"	Ultra-fine	<b>102-1080</b>	<b>13.70</b>
	60-C	.015"	Ultra-fine	<b>102-1085</b>	<b>13.70</b>
M. AlO	56	.093" x .037"	180	<b>102-1095</b>	<b>\$10.75</b>
	57	.125" x .037"	180	<b>102-1100</b>	<b>10.75</b>
	N. Crocus	56-C	.093" x .030"	Ultra-fine	<b>102-1115</b>



### 3M™ Radial Bristle Discs

Long-lasting, nonloading abrasive discs for cleaning, prepolishing, blending and removing scratches and firescale. Color-coded to denote grit, which is uniformly dispersed. Require no compound, so time-consuming cleanup is eliminated. Allow you to work faster and neater. Max. operating speed: 20,000rpm for 3" discs; 30,000rpm for all others. Recommended speed for most applications: 15,000rpm. See p. 131 for mandrels.

Color	Application
Brown	Removal of heaviest scratches
Green	Removal of heavy scratches
Yellow	Removal of scratches/firescale
White	Texturing, light cleaning
Red	Removal of light scratches/oxides
Blue	Blending, prepolishing
Pink	Very light cleaning, prepolishing
Peach	Polishing
Lt. Green	Final polishing

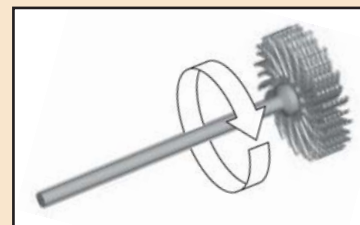

*Discs must be mounted and used as shown above.*

### A - C Discs for Rotary Handpieces

Dia. x AH	Color	Grit	Pkg. of 12		Pkg. of 48 w/ 3/32" shank mandrel	
			Item#	Each	Item#	Each
A. 9/16" x 1/16"	White	120	<b>145-1520</b>	<b>\$8.20</b>	<b>145-1620</b>	<b>\$30.45</b>
	Red	220	<b>145-1525</b>	<b>8.20</b>	<b>145-1625</b>	<b>30.45</b>
	Blue	400	<b>145-1530</b>	<b>8.20</b>	<b>145-1630</b>	<b>30.45</b>
	Pink	Pumice	<b>145-1535</b>	<b>8.20</b>	<b>145-1635</b>	<b>30.45</b>
	Peach	II	<b>145-1545</b>	<b>8.20</b>	<b>145-1645</b>	<b>30.45</b>
	Lt. Green	I	<b>145-1540</b>	<b>8.20</b>	<b>145-1640</b>	<b>30.45</b>
B. 3/4" x 1/16"	Yellow	80	<b>145-1500</b>	<b>8.40</b>	<b>145-1600</b>	<b>31.30</b>
	Red	220	<b>145-1505</b>	<b>8.40</b>	<b>145-1605</b>	<b>31.30</b>
	Blue	400	<b>145-1510</b>	<b>8.40</b>	<b>145-1610</b>	<b>31.30</b>
	Pink	Pumice	<b>145-1515</b>	<b>8.40</b>	<b>145-1615</b>	<b>31.30</b>

For use with rotary handpieces

Dia. x AH	Color	Grit	Pkg. of 12		Pkg. of 24 w/ 3/32" shank mandrel	
			Item#	Each	Item#	Each
C. 1" x 1/8"	Brown	36	<b>145-1550</b>	<b>\$10.25</b>	<b>145-1650</b>	<b>\$19.22</b>
	Green	50	<b>145-1555</b>	<b>10.25</b>	<b>145-1655</b>	<b>19.22</b>
	Yellow	80	<b>145-1560</b>	<b>10.25</b>	<b>145-1660</b>	<b>19.22</b>
	White	120	<b>145-1565</b>	<b>10.25</b>	<b>145-1665</b>	<b>19.22</b>

Description

Description	Item#	Each
45-Piece Small Disc Set (three of each disc above, two 3/32" shank mandrels and one 1/8" shank mandrel)	<b>145-1670</b>	<b>\$36.15</b>

### D, E Discs for Polishing Motors

Dia. x AH	Color	Grit	Pkg. of 10 w/hub		Pkg. of 40 w/hub	
			Item#	Each	Item#	Each
D. 2" x 3/8"	Yellow	80	<b>145-1745</b>	<b>\$20.50</b>	<b>145-1675</b>	<b>\$65.75</b>
	White	120	<b>145-1750</b>	<b>20.50</b>	<b>145-1680</b>	<b>65.75</b>
	Red	220	<b>145-1755</b>	<b>20.50</b>	<b>145-1685</b>	<b>65.75</b>
	Blue	400	<b>145-1760</b>	<b>20.50</b>	<b>145-1690</b>	<b>65.75</b>
	Pink	Pumice	<b>145-1765</b>	<b>20.50</b>	<b>145-1695</b>	<b>65.75</b>
	Peach	II	<b>145-1770</b>	<b>20.50</b>	<b>145-1700</b>	<b>65.75</b>
	Lt. Green	I	<b>145-1775</b>	<b>20.50</b>	<b>145-1705</b>	<b>65.75</b>
E. 3" x 3/8"	Yellow	80	<b>145-1780</b>	<b>27.50</b>	<b>145-1710</b>	<b>90.45</b>
	White	120	<b>145-1785</b>	<b>27.50</b>	<b>145-1715</b>	<b>90.45</b>
	Red	220	<b>145-1790</b>	<b>27.50</b>	<b>145-1720</b>	<b>90.45</b>
	Blue	400	<b>145-1795</b>	<b>27.50</b>	<b>145-1725</b>	<b>90.45</b>
	Pink	Pumice	<b>145-1800</b>	<b>27.50</b>	<b>145-1730</b>	<b>90.45</b>
	Peach	II	<b>145-1805</b>	<b>27.50</b>	<b>145-1735</b>	<b>90.45</b>
	Lt. Green	I	<b>145-1810</b>	<b>27.50</b>	<b>145-1740</b>	<b>90.45</b>

Description

Description	Item#	Each
22-Piece 2" Disc Set (three of each 2" disc above and one hub)	<b>145-1814</b>	<b>\$40.55</b>
22-Piece 3" Disc Set (three of each 3" disc above and one hub)	<b>145-1815</b>	<b>55.95</b>
Right-Side Tapered Spindle Adapter for 2" and 3" discs	145-1921	1.95
Left-Side Tapered Spindle Adapter for 2" and 3" discs	145-1922	1.95



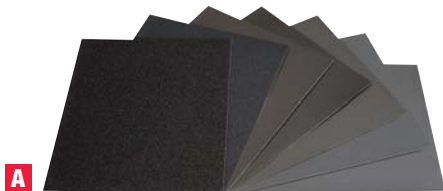

**A**

### **A Norton® Waterproof Paper**

Designed for wet or dry finishing. Silicon carbide abrasive provides superior cutting action. Yields long life in rough, wet applications. Sheets measure 9" x 11".



**B**

### **B Norton® Durite Abrasive Paper**

Made of fast-cutting, nonloading silicon carbide. Provides excellent wear. For intermediate and final dry sanding. Lightweight paper backing easily conforms to all shapes and angles. Sheets measure 9" x 11".

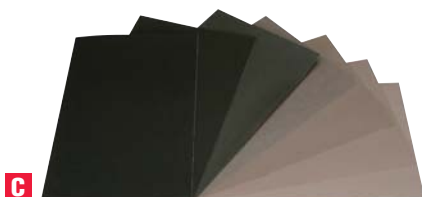

**C**

### **C Emery Polishing Paper**

Emery grains are black in color, a natural composite of corundum and iron oxide. This abrasive is glue-bonded on flexible, lightweight paper. It's slow-cutting and excellent for dry polishing, lapping and scratch removal. Can be wrapped around a stick to be used as a file or folded to form an edge. Finest grit is 4/0, coarsest is 3. Sheets measure 9" x 13<sup>3</sup>/<sub>4</sub>".



**D**

### **D 3M™ Wetordry™ Polishing Paper**

Very flexible paper with nonwoven backing. Easy polishing of interior shapes and contours. The 400 and 600 grits are silicon carbide. All other grits are aluminum oxide. Sheets measure 8<sup>1</sup>/<sub>2</sub>" x 11".

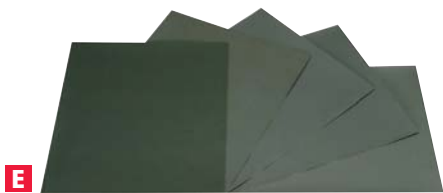

**E**

### **E 3M™ Wetordry™ Sheets**

Provide better cut rates and finishes and last longer than traditional emery sheets. Coarser grits come on heavyweight paper (431Q), and finer grits come on lightweight and flexible papers (413Q and 401Q, respectively). All silicon carbide. Sheets measure 9" x 11".

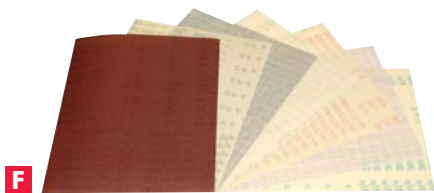

**F**

### **F 3M™ Imperial™ Microfinishing Film**

Precise micron-graded aluminum oxide resin-bonded to a polyester film backing. Nonloading for longer life and greater efficiency. For close tolerance polishing on metals, composites and plastic surfaces. Sheets measure 8<sup>1</sup>/<sub>2</sub>" x 11".

Grit	Item#	EACH Prices	
		5-45	50+
80	<b>109-7000</b>	<b>\$1.60</b>	<b>\$1.28</b>
120	<b>109-7010</b>	<b>1.40</b>	<b>1.05</b>

*Five-piece minimum; please order in multiples of five.*

Grit	Item#	EACH Prices	
		5-95	100+
120	<b>109-6050</b>	<b>\$.90</b>	<b>\$.63</b>
180	<b>109-6100</b>	<b>.90</b>	<b>.63</b>
220	<b>109-6150</b>	<b>.90</b>	<b>.63</b>
280	<b>109-6250</b>	<b>.90</b>	<b>.63</b>
320	<b>109-6300</b>	<b>.90</b>	<b>.63</b>

*Five-piece minimum; please order in multiples of five.*

Grit	Item#	EACH Prices		
		1-9	10-99	100+
3	<b>109-1750</b>	<b>\$2.50</b>	<b>\$1.68</b>	<b>\$1.18</b>
2	<b>109-1650</b>	<b>2.50</b>	<b>1.68</b>	<b>1.18</b>
1	<b>109-1550</b>	<b>2.50</b>	<b>1.68</b>	<b>1.18</b>
0	<b>109-1350</b>	<b>2.50</b>	<b>1.68</b>	<b>1.18</b>
2/0	<b>109-1250</b>	<b>2.85</b>	<b>1.91</b>	<b>1.34</b>
3/0	<b>109-1150</b>	<b>2.85</b>	<b>1.91</b>	<b>1.34</b>
4/0	<b>109-1050</b>	<b>2.85</b>	<b>1.91</b>	<b>1.34</b>

Color	Grit	Item#	Each
Green	400	<b>109-8001</b>	<b>\$.96</b>
Gray	600	<b>109-8005</b>	<b>.96</b>
Blue	1200	<b>109-8010</b>	<b>.96</b>
Pink	4000	<b>109-8015</b>	<b>.96</b>
Mint	6000	<b>109-8020</b>	<b>.96</b>
Light Green	8000	<b>109-8025</b>	<b>.96</b>

Grit	Paper Type	Item#	Each
80	431Q	<b>109-8185</b>	<b>\$1.15</b>
120	431Q	<b>109-8187</b>	<b>.89</b>
180	431Q	<b>109-8189</b>	<b>.79</b>
220	413Q	<b>109-8190</b>	<b>.79</b>
280	413Q	<b>109-8197</b>	<b>.79</b>
320	413Q	<b>109-8193</b>	<b>.79</b>
400	413Q	<b>109-8195</b>	<b>.79</b>
600	413Q	<b>109-8196</b>	<b>.88</b>
1000	401Q	<b>109-8200</b>	<b>1.18</b>
2000	401Q	<b>109-8203</b>	<b>1.18</b>
2500	401Q	<b>109-8204</b>	<b>1.18</b>

Color	Grit	Item#	Each
Brown	180	<b>109-8100</b>	<b>\$2.20</b>
Black	220	<b>109-8105</b>	<b>2.20</b>
Blue	320	<b>109-8110</b>	<b>2.20</b>
Green	400	<b>109-8115</b>	<b>2.20</b>
Red	500	<b>109-8125</b>	<b>2.20</b>
Orange	600	<b>109-8120</b>	<b>2.20</b>
Light Blue	1200	<b>109-8130</b>	<b>2.20</b>

**A PSA Strips**

These pressure-sensitive strips are made of aluminum oxide, glue-bonded on a cloth backing. Just press them onto a flat surface such as a wood stick. Strips measure 1" x 11".

Grit	Item#	Box of 100
80	<b>107-2550</b>	<b>\$34.35</b>
120	<b>107-2050</b>	<b>33.25</b>
180	<b>107-2150</b>	<b>33.25</b>
240	<b>107-2250</b>	<b>33.25</b>
320	<b>107-2300</b>	<b>33.25</b>
400	<b>107-2350</b>	<b>33.95</b>



**B - D Norton® Lightning Metalite Cloth**

A long-lasting abrasive cloth used to clean or polish metal surfaces for a high-quality finish. Glue-bonded aluminum oxide on lightweight, flexible cloth backing. Available in sheets or rolls. The 1" rolls can be used with our Polishing Stick (see p. 78), and 1½" rolls can be used with our Cone-Loc Drum (see below).

Description	Grit	Item#	EACH Prices	
			1-49	50+
<b>B. 9" x 11" Sheet</b>	180	<b>109-3650</b>	<b>\$1.45</b>	<b>\$1.16</b>
	240	<b>109-3750</b>	<b>1.45</b>	<b>1.16</b>
	320	<b>109-3850</b>	<b>1.45</b>	<b>1.16</b>
	400	<b>109-3950</b>	<b>1.45</b>	<b>1.16</b>
Description	Grit	Item#	Each	
<b>C. 1" x 50-yard Roll</b>	100	<b>109-5150</b>	<b>\$34.25</b>	
	120	<b>109-5200</b>	<b>34.25</b>	
	180	<b>109-5300</b>	<b>34.25</b>	
	240	<b>109-5350</b>	<b>34.25</b>	
	320	<b>109-5400</b>	<b>34.25</b>	
	400	<b>109-5450</b>	<b>34.25</b>	
	600	<b>109-5510</b>	<b>34.25</b>	
<b>D. 1½" x 50-yard Roll</b>	80	<b>109-5525</b>	<b>49.60</b>	
	120	<b>109-5545</b>	<b>49.60</b>	
	180	<b>109-5550</b>	<b>49.60</b>	
	240	<b>109-5600</b>	<b>49.60</b>	
	320	<b>109-5650</b>	<b>49.60</b>	

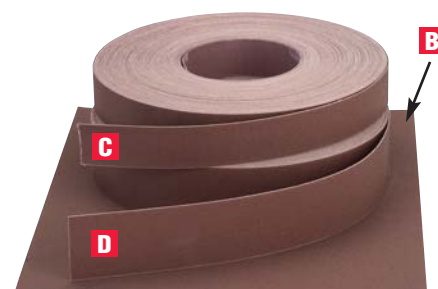

**E Cone-Loc Drum**

Used with abrasive cloth, this is an excellent tool for deburring and sprue removal. By sanding or grinding with this wheel, hand filing can be practically eliminated. Made of heavy-gauge aluminum casting. Drum is covered by ½" thick rubber covering. Rubber covering allows surface to conform to work. Measures 6" dia. x 1½"W x ½"AH. Weighs 2 lbs. Maximum operating speed: 4,000rpm. Use with Lightning Metalite Cloth 1½" rolls (see above). Refer to p. 136 for arbors.

Description	Item#	Each
Cone-Loc Drum	<b>840-1256</b>	<b>\$150.00</b>



**F - H Split Mandrels – 3/32" Shank**

For holding strips of abrasive paper and cloth. All 3/32" shank.

Head	Diameter	Item#	EACH Prices	
			1-11	12+
<b>F. Straight</b>	11/64"	<b>840-3405</b>	<b>\$2.40</b>	<b>\$2.00</b>
<b>G. Straight</b>	9/64"	<b>840-3406</b>	<b>2.40</b>	<b>2.00</b>
<b>H. Tapered</b>	3/32" to 3/16"	<b>840-3407</b>	<b>2.40</b>	<b>2.00</b>



## A, B Gesswein™ Belt Sticks and Belts

Economical, versatile tools that accommodate 1/4", 1/2" or 3/4" wide abrasive belts, for sanding and smoothing hard-to-reach areas. Made of impact-resistant polypropylene. The tip can be easily reshaped to meet your exact needs. A spring-loaded tensioning device allows the abrasive belt to be rotated so that all areas of the belt can be used and facilitates quick belt changing. Belt Sticks may be used dry or with water, oil, or solvents. Sticks and belts are color-coded to help you identify one belt grit from another. Abrasive belts are resin-bonded, cloth-backed aluminum oxide.



**A**

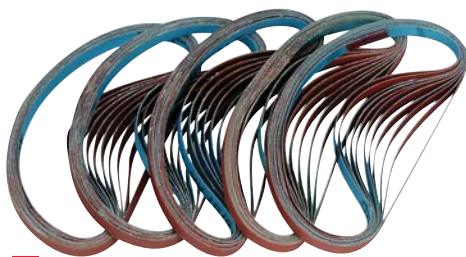

**B**

A. Belt Stick w/Belt					
Width	Color	Grit	Item#	Each	
1/4"	Red	120	<b>107-3610</b>	<b>\$1.65</b>	
	Blue	240	<b>107-3612</b>	<b>1.65</b>	
	Green	320	<b>107-3614</b>	<b>1.65</b>	
	Yellow	400	<b>107-3616</b>	<b>1.65</b>	
	Black	600	<b>107-3618</b>	<b>1.65</b>	
1/2"	Red	120	<b>107-3640</b>	<b>2.95</b>	
	Blue	240	<b>107-3642</b>	<b>2.95</b>	
	Green	320	<b>107-3644</b>	<b>2.95</b>	
3/4"	Red	120	<b>107-3670</b>	<b>3.75</b>	
	Blue	240	<b>107-3672</b>	<b>3.75</b>	
	Green	320	<b>107-3674</b>	<b>3.75</b>	
B. Extra Belts					
Width	Color	Grit	Item#	PKG. of 10	
1/4"	Red	120	<b>107-3621</b>	<b>\$5.40</b>	<b>\$4.86</b>
	Blue	240	<b>107-3625</b>	<b>5.40</b>	<b>4.86</b>
	Green	320	<b>107-3627</b>	<b>5.40</b>	<b>4.86</b>
	Yellow	400	<b>107-3628</b>	<b>5.40</b>	<b>4.86</b>
	Black	600	<b>107-3629</b>	<b>5.40</b>	<b>4.86</b>
1/2"	Red	120	<b>107-3651</b>	<b>7.50</b>	<b>6.75</b>
	Blue	240	<b>107-3655</b>	<b>7.50</b>	<b>6.75</b>
	Green	320	<b>107-3657</b>	<b>7.50</b>	<b>6.75</b>
3/4"	Red	120	<b>107-3681</b>	<b>9.95</b>	<b>8.96</b>
	Blue	240	<b>107-3685</b>	<b>9.95</b>	<b>8.96</b>
	Green	320	<b>107-3687</b>	<b>9.95</b>	<b>8.96</b>

## C Gesswein™ Belt Stick and Belt Sets

Choose from four sets: **21-Piece Set** includes 1/4" red, blue and green belt sticks with one belt each, plus 15 extra belts (five each in 120, 240 and 320 grit); **36-Piece Set** includes 1/4" red, blue and green belt sticks with one belt each, plus 30 extra belts (ten each in 120, 240 and 320 grit); **60 Piece Set** includes 1/4" red, blue, green, yellow and black belt sticks with one belt each, plus 50 extra belts (ten each in 120, 240, 320, 400 and 600 grit); and **42-Piece Large Set** includes 1/2" and 3/4" red, blue and green belt sticks with one belt each, plus 30 extra belts (five each of 1/2" and 3/4" in 120, 240 and 320 grit.)

Description	Item#	Each
21-Piece Set	<b>107-3603</b>	<b>\$11.95</b>
36-Piece Set	<b>107-3605</b>	<b>18.65</b>
60-Piece Set	<b>107-3606</b>	<b>31.35</b>
<b>C. 42-Piece Set</b>	<b>107-3660</b>	<b>54.95</b>

## D - F Polishing Sticks

Use these tools as you would a file to smooth, debur and polish metal. Hold abrasive cloth and paper in 11" strips. Strips are easy to insert and remove and are held securely. Measure 10" overall length. Sanding surfaces measure 5" long, tapering from approximately 3/8" thick at the handle to 1/16" at the tip. Made of high-impact, solvent-resistant plastic. (For refills, use Lightning Metalite Cloth rolls or sheets – see p. 77) Available in two styles: flat (both sides) and half-round (one side concave, the other convex – for smoothing and radiusing contoured surfaces).



**D**

**E**

**F**

*Abrasive strips not included.*

Description	Shape	Item#	Each
<b>D. Half-Round Stick, 1/2" width</b>	⤿	<b>813-1952</b>	<b>\$12.45</b>
<b>E. Half-Round Stick, 1" width</b>	⤿	<b>813-1951</b>	<b>12.45</b>
<b>F. Flat Stick, 1" width</b>	—	<b>813-1950</b>	<b>12.45</b>



**A - D Micro-Mesh® – Cushioned abrasive for producing an ultra-fine finish.**

Micro-Mesh features abrasive crystals (80–600 grit are silicon carbide; 800 and 1200 are aluminum oxide) that recede into resilient backing and “float” to an even cutting plane. Eliminates random deep scratches and produces a fine, even finish. Cuts faster than traditional abrasives due to large crystal design and high abrasive contact with the workpiece. A 400 grit Micro-Mesh will cut like a 400–600 grit but leave an 800–1000 grit finish. Can be used dry or wet. Outlasts common abrasives 5–7 times when used dry, 7–15 times when used with oil or water.

A. Sheets		6" x 12"		12" x 12"	
Grit	Item#	Each	Item#	Each	
80	107-3030	\$9.95	107-3050	\$16.50	
100	107-3031	9.95	107-3051	16.50	
120	107-3032	9.95	107-3052	16.50	
150	107-3033	9.95	107-3053	16.50	
180	107-3034	9.95	107-3054	16.50	
240	107-3035	9.95	107-3055	16.50	
320	107-3036	9.95	107-3056	16.50	
360	107-3037	9.95	107-3057	16.50	
400	107-3038	9.95	107-3058	16.50	
600	107-3039	9.95	107-3059	16.50	
800	107-3040	9.95	107-3060	16.50	
1200	107-3041	9.95	107-3061	16.50	

B. Discs		¾" Dia.	Pkg.	1" Dia.	Pkg.	1½" Dia.	Pkg.
Grit	Item#	of 50	Item#	of 50	Item#	of 50	
80	107-3070	\$14.00	107-3090	\$14.00	107-3102	\$16.00	
100	107-3071	14.00	107-3091	14.00	107-3103	16.00	
120	107-3072	14.00	107-3092	14.00	107-3104	16.00	
150	107-3073	14.00	107-3093	14.00	107-3105	16.00	
180	107-3074	14.00	107-3094	14.00	107-3106	16.00	
240	107-3075	14.00	107-3095	14.00	107-3107	16.00	
320	107-3076	14.00	107-3096	14.00	107-3108	16.00	
360	107-3077	14.00	107-3097	14.00	107-3109	16.00	
400	107-3078	14.00	107-3098	14.00	107-3110	16.00	
600	107-3079	14.00	107-3099	14.00	107-3111	16.00	
800	107-3080	14.00	107-3100	14.00	107-3112	16.00	
1200	107-3081	14.00	107-3101	14.00	107-3113	16.00	

C. Disc Holders	Dia.	⅛" Shank	¼" Shank	EACH Prices	
		Item#	Item#	1-2	3+
¾"		840-0030	840-0040	\$2.85	\$2.37
1"		840-0050	840-0060	3.25	2.71
1½"		840-0070	840-0080	3.75	3.12

D. Two-Sided Files, ½" x 5¾"		EACH Prices	
Grits	Item#	1-11	12+
100/150	107-3114	\$1.70	\$1.53
180/240	107-3115	1.70	1.53
400/600	107-3116	1.70	1.53
Sample Set	Item#		Each
Eleven 3" x 6" Sheets (one each of 100–1200 grit) and one of each File	107-3062		\$34.50



**A**

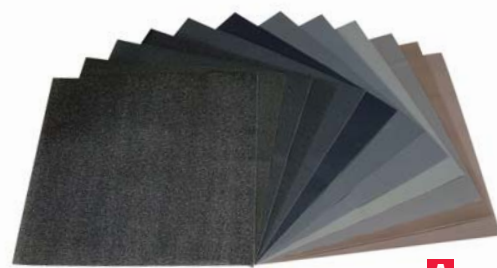

**B**



**C**



**D**

**E 3M® Sponge Sanding Pads**

Flexible, durable closed-cell rubber pads with aluminum oxide abrasive. Use dry or wet on almost any surface contour. Will not gouge. Measure 4½" x 5½" (can be trimmed as desired).

Grit	Item#	EACH Prices		
		1-4	5-19	20+
Medium	108-7020	\$1.20	\$1.10	\$1.05
Fine	108-7015	1.20	1.10	1.05
Super-Fine	108-7010	1.20	1.10	1.05
Ultra-Fine	108-7005	1.95	1.79	1.71
Micro-Fine	108-7000	1.95	1.79	1.71
E. 5-Piece Set (one of each)	108-7025	7.55	-	-

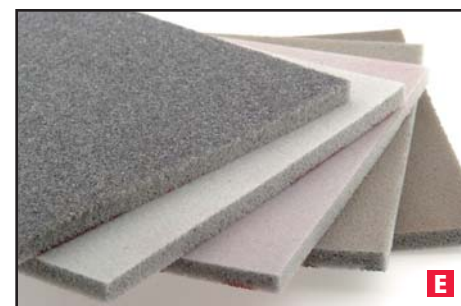

**E**

## ULTRAMAX® Ultrasonic Polishing Systems – Reduce finishing time by more than 50%!

For more than two decades, Gesswein has brought the benefits of ultrasonic polishing to mold and diemakers. ULTRAMAX units polish slots, ribs and intricate details faster than you could ever do by hand. Feature fast reciprocation and short stroke for making quick work of the most demanding tasks. Provide total control for polishing right up to a wall or edge with confidence. Broad operating frequency range allows a wider selection of tools to be used.

Automatic frequency adjustment ensures maximum tool efficiency. Regulated power feedback increases handpiece transducer life and keeps handpiece and tools cool.

With their high output power, **DF** and **SF** units are unaffected by metal hardness. Handle even the toughest metals with ease, including tungsten carbide and titanium. Polish everything from milled to rough EDM surfaces to a mirror finish using all grades of finishing stones, diamond tools,

ceramic stones and lapping tools with diamond compound (see pp. 144–145).

If you intend to work with diamond tools or ceramic stones only, then consider the affordable **UM-1200**. This slightly less powerful unit polishes everything from milled to rough EDM surfaces to a mirror finish using progressively finer abrasives.



### A ULTRAMAX® DF (Dual-Function) Ultrasonic/Mechanical Polisher

This dual-function unit gives you the versatility of both ultrasonic and mechanical polishing. Supplied with the lightweight, vibration-free UF-9700 ultrasonic handpiece and can use our full line of Power Hand 2X mechanical handpieces (see pp. 90–98). The ULTRAMAX DF mechanical handpiece function incorporates speed control, forward/reverse touch pads and motor stop for complete armature protection.

Includes controller, UF-9700 handpiece with 6mm screw thread, 6/4mm tool adapter attached (to hold M4 ultrasonic tools on pp. 82–83), handpiece cradle rest and tool box with a 31-piece tool set of four diamond files, three diamond stones, two resin-bonded diamond stones, six ceramic stones, two lapping tools, four flat clamp tool holders, round clamp tool holder, standard handpiece protector sleeve, large beveled handpiece protector sleeve, wrenches, set of earplugs and extra fuse.

Vibration frequency: 20–30kHz. Stroke length: 4–40 microns. Max. output power: 45W. Electrical: 115V or 230V, 1 Ph, 50/60Hz. Controller measures 6<sup>3</sup>/<sub>8</sub>"W x 11"D x 8<sup>1</sup>/<sub>4</sub>"H. Handpiece measures 5"L x 1<sup>3</sup>/<sub>32</sub>" dia.

Description	Electrical	Item#	Each
ULTRAMAX DF	115V	<b>500-0210</b>	<b>\$5,245.00</b>
	230V	<b>500-0211</b>	<b>5,245.00</b>



### B ULTRAMAX® SF (Single-Function) Ultrasonic Polisher

If you don't need a mechanical handpiece function on your ultrasonic polisher, this single-function unit is for you. Supplied with the lightweight, vibration-free UF-9700 ultrasonic handpiece. ULTRAMAX SF has the same ultrasonic polishing capabilities as ULTRAMAX DF.

Includes controller, UF-9700 handpiece with 6mm screw thread, 6/4mm tool adapter attached (to hold M4 ultrasonic tools on pp. 82–83), handpiece cradle rest and tool box with a 31-piece tool set of four diamond files, three diamond stones, two resin-bonded diamond stones, six ceramic stones, two lapping tools, four flat clamp tool holders, round clamp tool holder, standard handpiece protector sleeve, large beveled handpiece protector sleeve, wrenches, set of earplugs and extra fuse.

Vibration frequency: 20–30kHz. Stroke length: 4–40 microns. Max. output power: 45W. Electrical: 115V or 230V, 1 Ph, 50/60Hz. Controller measures 7"W x 8<sup>1</sup>/<sub>4</sub>"D x 6"H. Handpiece measures 5"L x 1<sup>3</sup>/<sub>32</sub>" dia.

Description	Electrical	Item#	Each
ULTRAMAX SF	115V	<b>500-0200</b>	<b>\$4,825.00</b>
	230V	<b>500-0201</b>	<b>4,825.00</b>

## Safety Recommendations – For ULTRAMAX DF Mechanical Function.

Prolonged use of vibrating or reciprocating tools may result in vibration-induced circulation problems in the hands. Always follow safe operating procedures. Using hand protection (i.e., insulated gloves) and taking frequent breaks can help minimize but not guarantee against injury. Operating these types of tools in cold weather or with a tight grip will reduce the period of operation before risking potential injury. Individuals with a tendency to suffer from poor circulation, frequently cold fingers or itchy hands should closely monitor the condition of their hands. If symptoms appear, seek medical advice immediately.

**A, B ULTRAMAX® DF/SF Accessories and Replacements**

Description	Item#	Each
<b>A.</b> Variable-Speed Foot Rheostat	<b>500-0206</b>	<b>\$149.00</b>
<b>B.</b> On/Off Foot Switch	<b>500-0207</b>	<b>81.00</b>
UF-9700 Handpiece only	500-0205 <sup>1</sup>	1,235.00
6/4mm Tool Adapter (to hold M4 ultrasonic tools)	508-3342 <sup>1</sup>	13.25
Handpiece Cradle Rest	500-1013 <sup>1</sup>	28.70
Standard Handpiece Protector Sleeve	500-0208 <sup>1</sup>	12.75
Large Beveled Handpiece Protector Sleeve	500-0209 <sup>1</sup>	15.75

<sup>1</sup>Supplied with ULTRAMAX DF/SF.



**C ULTRAMAX® UM-1200 Ultrasonic Polisher**

The affordable and functional ultrasonic polisher (no mechanical function) for polishing with diamond tools and ceramic stones. Includes controller, UM-1200 handpiece with 8mm screw thread (see below for 8/4mm tool adapter to hold M4 ultrasonic tools shown on pp. 82–83), standard accessory set (two sintered and six plated diamond tools and two ceramic stones), one flat clamp tool holder, two round clamp tool holders, on/off foot switch, handpiece cradle rest, bench jig, wrench and hex key.

Vibration frequency: 18–25kHz. Stroke length: 10–35 microns. Max. output power: 36W. Electrical: 90–240V, 50/60Hz. Controller measures 7½"W x 5½"D x 3½"H. Handpiece measures 5"L x 1⅜" dia.

Description	Electrical	Item#	Each
ULTRAMAX UM-1200	90–240V	<b>500-1200</b>	<b>\$1,495.00</b>



**D - G ULTRAMAX® UM-1200 Electroplated Diamond Tapered Machine Files**

Feature plated diamond portion that measures 15mm (approx. 5/8") long x 1.4–0.3mm thick. Have 3mm shanks. Use with proper tool holder (see p. 84).

Size (W x L)	200 grit Item#	400 grit Item#	600 grit Item#	Each
<b>D.</b> 3 x 56mm	<b>500-0119<sup>2</sup></b>	<b>500-0120</b>	<b>500-0121</b>	<b>\$6.00</b>
<b>E.</b> 6 x 56mm	<b>500-0122</b>	<b>500-0123<sup>2</sup></b>	<b>500-0124</b>	<b>6.00</b>
<b>F.</b> 3 x 72mm	<b>500-0113<sup>2</sup></b>	<b>500-0114<sup>2</sup></b>	<b>500-0115</b>	<b>6.00</b>
<b>G.</b> 6 x 72mm	<b>500-0116<sup>2</sup></b>	<b>500-0117<sup>2</sup></b>	<b>500-0118</b>	<b>6.00</b>
Description	Item#			Each
12-Piece Set (one each of above)	<b>500-0125</b>			<b>\$60.00</b>

<sup>2</sup>Supplied with ULTRAMAX UM-1200.

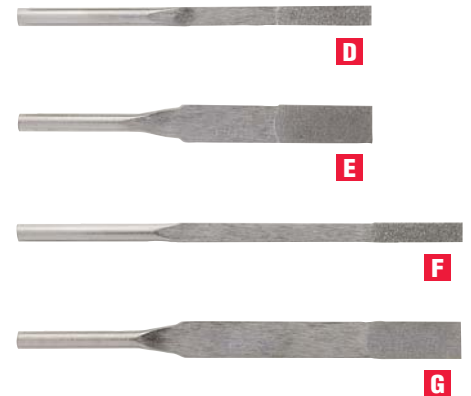

**H ULTRAMAX® UM-1200 Sintered Diamond Machine Files**

Feature solid diamond portion that measures 20mm (approx. 3/4") long x 1.5mm thick. Shape to reach tight areas. Have 3mm shanks. Use with proper tool holder (see p. 84).

Size (W x L)	200 grit Item#	400 grit Item#	600 grit Item#	Each
6 x 72mm	<b>500-0126<sup>2</sup></b>	<b>500-0127<sup>2</sup></b>	<b>500-0128</b>	<b>\$49.95</b>

<sup>2</sup>Supplied with ULTRAMAX UM-1200.



**I ULTRAMAX® UM-1200 Accessories and Replacements**

Description	Item#	Each
<b>I.</b> 8/4mm Tool Adapter (to hold M4 ultrasonic tools)	<b>500-0129</b>	<b>\$24.90</b>
UM-1200 Handpiece only	500-0101 <sup>2</sup>	380.00
Standard Accessory Set	500-0140 <sup>2</sup>	126.00
On/Off Foot Switch	500-0107 <sup>2</sup>	45.00
Handpiece Cradle Rest	510-1130 <sup>2</sup>	14.60
Bench Jig	500-0104 <sup>2</sup>	11.35
10/11mm Spanner Wrench	500-0138 <sup>2</sup>	4.50
2.5mm Hex Key	500-0112 <sup>2</sup>	2.00

<sup>2</sup>Supplied with ULTRAMAX UM-1200.



# Ultrasonic Polishers

## ULTRAMAX® Tools – M4 (4mm thread)

All ULTRAMAX tools are made to match the resonant frequency of Gesswein ULTRAMAX units. For best results, use only ULTRAMAX tools. The manufacturer will not accept any liability for another brand of tools.

### Millimeter Conversions

0.5mm = .0197"	4mm = .1575"	9mm = .3543"
0.8mm = .0315"	5mm = .1969"	10mm = .3937"
1mm = .0394"	6mm = .2362"	15mm = .5906"
2mm = .0787"	7mm = .2756"	20mm = .7874"
3mm = .1181"	8mm = .3150"	40mm = 1.5748"

### Diamond Color Coding

Color	Grit	Micron
Red	200	68
Black	320	40
Blue	500	35
White	600	28

## Mounted Diamond Files – For ULTRAMAX® units

Use these fast-cutting diamond files for intermediate finishing. Excellent for finishing slot sidewalls and flat or curved surfaces. Diamond particles, precision-graded to assure consistency, are electro-deposited on threaded steel shanks. Mount in 6/4mm tool adapter supplied with UF-9700 handpiece for use with DF or SF. Mount in 8/4mm tool adapter (see p. 81) for use with UM-1200. All measurements in millimeters.

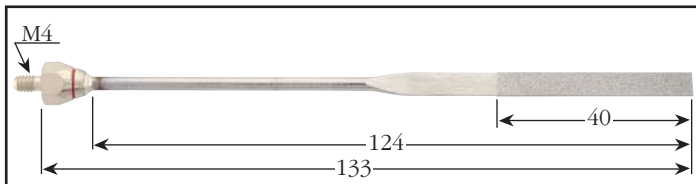

Flat, 5 x 1 x 40 Grit	Item#	Each
200	<b>508-3206<sup>1</sup></b>	<b>\$92.80</b>
320	<b>508-3208<sup>1</sup></b>	<b>92.80</b>
600	<b>508-3210</b>	<b>92.80</b>

*4mm thread  
<sup>1</sup>Supplied with ULTRAMAX DF/SF.*

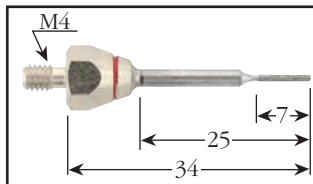

Round, 1 x 7 Grit	Item#	Each
200	<b>508-3180</b>	<b>\$35.70</b>
320	<b>508-3181</b>	<b>35.70</b>
600	<b>508-3182</b>	<b>35.70</b>

*4mm thread*

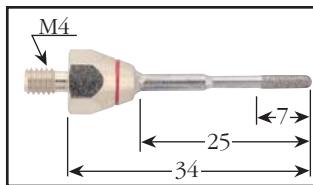

Round, 2 x 7 Grit	Item#	Each
200	<b>508-3184</b>	<b>\$35.70</b>
320	<b>508-3185</b>	<b>35.70</b>
600	<b>508-3186</b>	<b>35.70</b>

*4mm thread*

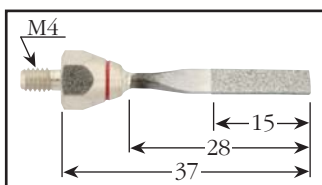

Flat, 4 x 1 x 15 Grit	Item#	Each
200	<b>508-3200</b>	<b>\$66.00</b>
320	<b>508-3202</b>	<b>66.00</b>
600	<b>508-3204</b>	<b>66.00</b>

*4mm thread*

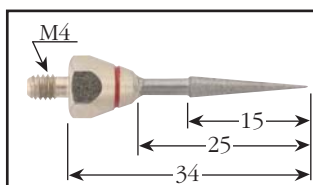

Round Taper, 3 x 15 Grit	Item#	Each
200	<b>508-3215</b>	<b>\$49.95</b>
320	<b>508-3217</b>	<b>49.95</b>
600	<b>508-3219</b>	<b>49.95</b>

*4mm thread*

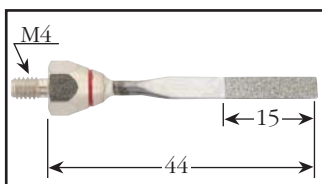

Chisel, 4 x 0.8-0.5 x 15 Grit	Item#	Each
200	<b>508-3362<sup>1</sup></b>	<b>\$67.25</b>
320	<b>508-3364<sup>1</sup></b>	<b>67.25</b>
600	<b>508-3366</b>	<b>67.25</b>

*4mm thread  
<sup>1</sup>Supplied with ULTRAMAX DF/SF.*

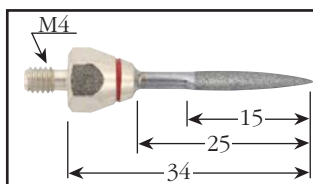

Oval Taper, 3 x 2 x 15 Grit	Item#	Each
200	<b>508-3176</b>	<b>\$53.85</b>
320	<b>508-3177</b>	<b>53.85</b>
600	<b>508-3178</b>	<b>53.85</b>

*4mm thread*

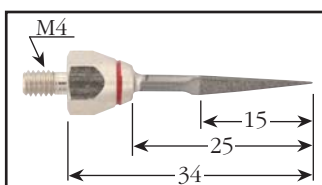

Three-Square, 3 x 15 Grit	Item#	Each
200	<b>508-3212</b>	<b>\$76.00</b>
320	<b>508-3214</b>	<b>76.00</b>
600	<b>508-3213</b>	<b>76.00</b>

*4mm thread*

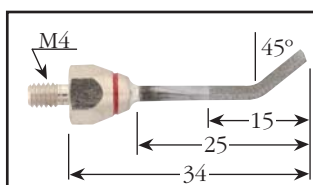

45° Arm, 1 x 4 x 15 Grit	Item#	Each
200	<b>508-3218</b>	<b>\$61.75</b>
320	<b>508-3220</b>	<b>61.75</b>
600	<b>508-3222</b>	<b>61.75</b>

*4mm thread*



## Mounted Diamond Stones – For ULTRAMAX® units

Precision-graded diamond particles throughout, not just on the surface, give these tools long life. Mount in 6/4mm tool adapter supplied with UF-9700 handpiece for use with DF or SF. Mount in 8/4mm tool adapter (see p. 81) for use with UM-1200. Can be shaped with a diamond wheel or file for easy polishing of tapered or deep, narrow slots. Great for intermediate and fine finishing. All measurements in millimeters. All lengths given are cutting lengths. Please check drawings for overall tool dimensions.

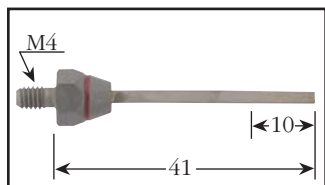

Flat, 2 x 1 x 10			
Grit	Item#	Each	
200	<b>508-3240</b>	<b>\$75.25</b>	
320	<b>508-3242</b>	<b>75.25</b>	
500	<b>508-3244</b>	<b>75.25</b>	

4mm thread

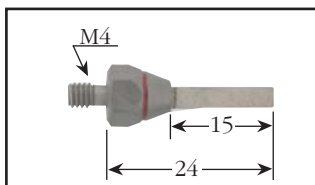

Flat, 3 x 1 x 15			
Grit	Item#	Each	
200	<b>508-3264</b>	<b>\$88.85</b>	
320	<b>508-3266</b>	<b>88.85</b>	
500	<b>508-3268</b>	<b>88.85</b>	

4mm thread

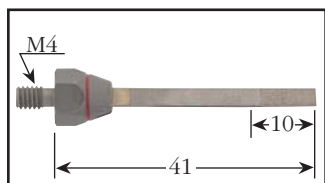

Flat, 3 x 1 x 10			
Grit	Item#	Each	
200	<b>508-3246<sup>1</sup></b>	<b>\$97.25</b>	
320	<b>508-3248</b>	<b>97.25</b>	
500	<b>508-3250</b>	<b>97.25</b>	

4mm thread

<sup>1</sup>Supplied with ULTRAMAX DF/SF.

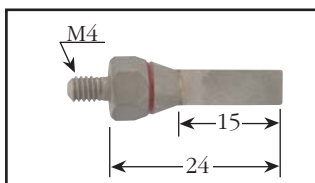

Flat, 5 x 1 x 15			
Grit	Item#	Each	
200	<b>508-3272</b>	<b>\$73.75</b>	
320	<b>508-3274</b>	<b>73.75</b>	
500	<b>508-3270</b>	<b>73.75</b>	

4mm thread

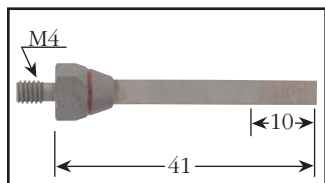

Flat, 4 x 1 x 10			
Grit	Item#	Each	
200	<b>508-3252</b>	<b>\$102.25</b>	
320	<b>508-3254</b>	<b>102.25</b>	
500	<b>508-3256</b>	<b>102.25</b>	

4mm thread

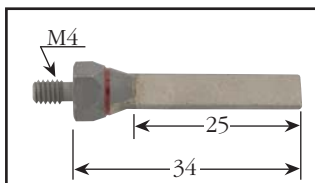

Flat, 6 x 1.5 x 25			
Grit	Item#	Each	
200	<b>508-3276<sup>1</sup></b>	<b>\$107.75</b>	
320	<b>508-3278</b>	<b>107.75</b>	
500	<b>508-3280</b>	<b>107.75</b>	

4mm thread

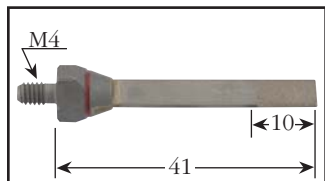

Flat, 5 x 1 x 10			
Grit	Item#	Each	
200	<b>508-3258<sup>1</sup></b>	<b>\$106.75</b>	
320	<b>508-3260</b>	<b>106.75</b>	
500	<b>508-3262</b>	<b>106.75</b>	

4mm thread

<sup>1</sup>Supplied with ULTRAMAX DF/SF.

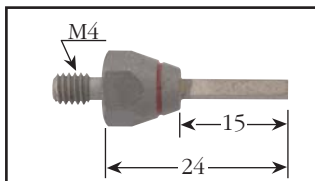

Square, 2 x 2 x 15			
Grit	Item#	Each	
200	<b>508-3281</b>	<b>\$60.00</b>	
320	<b>508-3282</b>	<b>60.00</b>	
500	<b>508-3284</b>	<b>60.00</b>	

4mm thread

## Mounted Ruby® Stones – For ULTRAMAX® units

Precision-graded particle size (17 microns) for fine finishing. These ruby stones cut hard steels and carbide. Provide fast cutting on soft surfaces. They hold their shape well and can be easily dressed with a diamond file or stone for finishing intricate surfaces. Ideal for fine detail work and squaring off rounded corners. Mount in 6/4mm tool adapter supplied with UF-9700 handpiece for use with DF or SF. Mount in 8/4mm tool adapter (see p. 81) for use with UM-1200. All measurements in millimeters. All lengths given are cutting lengths. Please check drawings for overall tool dimensions.

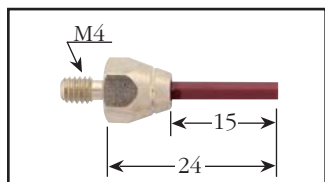

Square, T x T x 15			
T	Item#	Each	
2	<b>508-1360</b>	<b>\$26.00</b>	
3	<b>508-1365</b>	<b>26.00</b>	

4mm thread

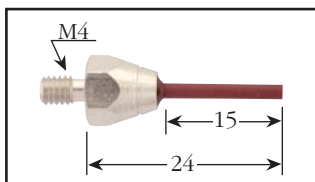

Round, Dø x 15			
Dø	Item#	Each	
2	<b>508-1350</b>	<b>\$26.00</b>	
3	<b>508-1355</b>	<b>26.00</b>	

4mm thread

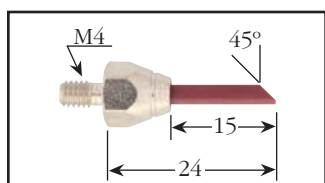

Square with 45° Bevel, T x T x 15			
T	Item#	Each	
2	<b>508-1370</b>	<b>\$29.20</b>	
3	<b>508-1375</b>	<b>29.20</b>	

4mm thread

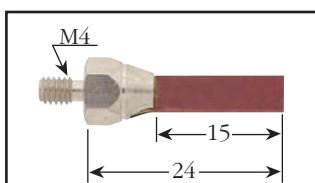

Flat, T x 5 x 15			
T	Item#	Each	
1	<b>508-1380</b>	<b>\$29.20</b>	
2	<b>508-1385</b>	<b>29.20</b>	

4mm thread

## ULTRAMAX® DF/SF and UM-1200 Clamp Tool Holders

Create your own polishing tools by inserting stones and lapping joints into the appropriate steel clamp. Use the M6 (6mm thread) clamp tool holders in the UF-9700 ultrasonic handpiece supplied with ULTRAMAX DF and SF. For optimum machine performance, choose a medium clamp tool holder for tools up to 6.35mm in width and a large clamp tool holder for tools up to 15mm in width. Use the M8 (8mm thread) clamp tool holders in the UM-1200 ultrasonic handpiece supplied with ULTRAMAX UM-1200. Replacement screws are available from stock.

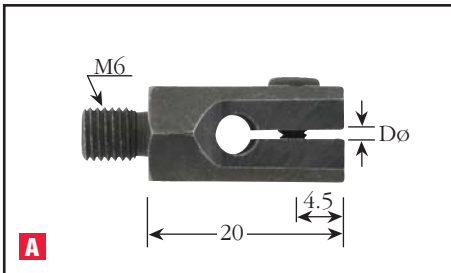

### A - C DF/SF Clamp Tool Holders – For UF-9700 handpiece

#### A 6mm Thread Round Clamp Tool Holder – For round tools

For Dø	Item#	Each
2.0mm round tool	<b>508-3508</b>	<b>\$36.50</b>
2.35mm round tool	<b>508-3509</b>	<b>36.50</b>
3.0mm round tool	<b>508-3512<sup>1</sup></b>	<b>36.50</b>
3.3mm (1/8") round tool	<b>508-3516</b>	<b>36.50</b>
4.0mm round tool	<b>508-3520</b>	<b>36.50</b>

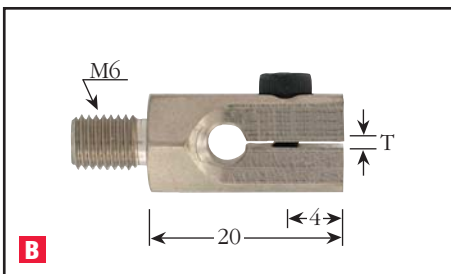

#### B 6mm Thread Medium Clamp Tool Holder – For flat tools up to 6.35mm wide

For T	Item#	Each
0.5mm flat tool	<b>508-3495</b>	<b>\$36.50</b>
0.8mm flat tool	<b>508-3500<sup>1</sup></b>	<b>36.50</b>
1.0mm flat tool	<b>508-3502<sup>1</sup></b>	<b>36.50</b>
1.5mm flat tool	<b>508-3504</b>	<b>36.50</b>
2.0mm flat tool	<b>508-3506</b>	<b>36.50</b>
3.0mm flat tool	<b>508-3510<sup>1</sup></b>	<b>36.50</b>
3.3mm (1/8") flat tool	<b>508-3514<sup>1</sup></b>	<b>36.50</b>

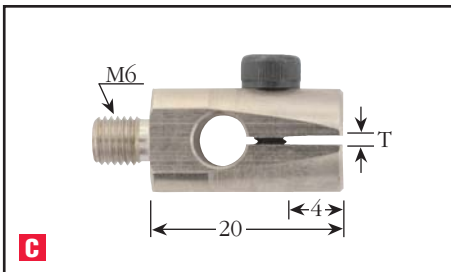

#### C 6mm Thread Large Clamp Tool Holder – For flat tools 6.35mm to 15mm wide

For T	Item#	Each
1.0mm flat tool	<b>508-3503</b>	<b>\$36.50</b>
1.5mm flat tool	<b>508-3505</b>	<b>36.50</b>
2.0mm flat tool	<b>508-3507</b>	<b>36.50</b>
3.0mm flat tool	<b>508-3511</b>	<b>36.50</b>
3.3mm (1/8") flat tool	<b>508-3515</b>	<b>36.50</b>
4.0mm flat tool	<b>508-3518</b>	<b>36.50</b>

<sup>1</sup>Supplied with ULTRAMAX DF/SF.

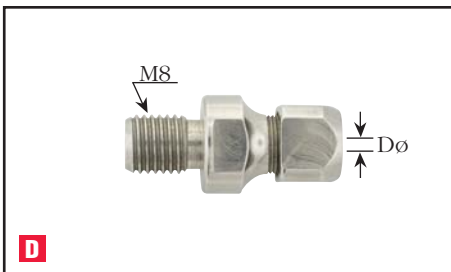

### D, E UM-1200 Clamp Tool Holders – For UM-1200 handpiece

For holding diamond tools and ceramic stones. **Important note: Always use bench jig when changing tools or holders to avoid damaging handpiece transducer wires.**

#### D 8mm Thread Round Clamp Tool Holder – For round tools

For Dø	Item#	Each
1.0mm round tool	<b>500-0134</b>	<b>\$32.00</b>
2.0mm round tool	<b>500-0135</b>	<b>32.00</b>
2.35mm round tool	<b>500-0136</b>	<b>32.00</b>
3.0mm round tool	<b>500-0109<sup>2</sup></b>	<b>28.00</b>
1/8" round tool	<b>500-0137</b>	<b>32.00</b>

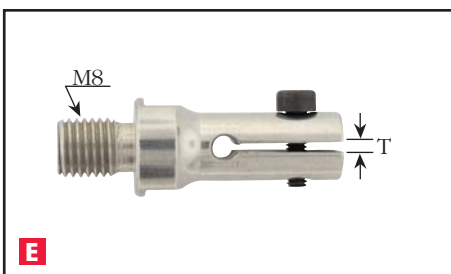

#### E 8mm Thread Flat Clamp Tool Holder – For flat tools

For T	Item#	Each
0.5mm flat tool	<b>500-0111</b>	<b>\$28.00</b>
0.8mm flat tool	<b>500-0131</b>	<b>28.00</b>
1.0mm flat tool	<b>500-0108<sup>2</sup></b>	<b>28.00</b>
2.0mm flat tool	<b>500-0132</b>	<b>28.00</b>
3.0mm flat tool	<b>500-0110</b>	<b>28.00</b>
1/8" flat tool	<b>500-0133</b>	<b>28.00</b>

<sup>2</sup>Supplied with ULTRAMAX UM-1200.

**Super Ceramic Stones – Perfect for use with ULTRAMAX units!**

These strong yet incredibly flexible stones form an unbeatable combination with ULTRAMAX ultrasonic polishers. Made of long ceramic fibers that will not break or dull, even when used under the most strenuous conditions or dressed to a very fine point. Put an end to constant stone replacement: 100% of each stone is available for use due to solid ceramic construction. Can be used with fantastic results in our ULTRAMAX ultrasonic handpieces, in Power Hand 2X reciprocating and rotary handpieces or by hand, making them very versatile. Impart uniform surface finishes on molds, dies and precision components. Produce excellent finishing results on stainless steel, copper, aluminum, alloys, silicon, magnetic materials and plastics. Use with ULTRAMAX units to polish any EDM surface in just half the time! Sold in precut and standard sizes. Color-coded for easy grit identification. Dress with Super Dresser (see p. 23). Select appropriate clamp tool holder from p. 84 and hand holder from p. 23.



**Precut Super Ceramic Stones**

Choose from flat and round sizes precut for use with ULTRAMAX.

FLAT	Emerald (120 grit) Item#	Gold (180 grit) Item#	Lt. Brown (300 grit) Item#	Orange (400 grit) Item#	Brown (600 grit) Item#	Each	Blue (800 grit) Item#	White (1000 grit) Item#	Red (1200 grit) Item#	Each
0.8 x 4 x 40	<b>508-3550</b>	<b>508-3438</b>	<b>508-3448</b>	<b>508-3449</b>	<b>508-3450<sup>1</sup></b>	<b>\$14.75</b>	<b>508-3451<sup>1</sup></b>	<b>508-3452</b>	<b>508-3453</b>	<b>\$12.50</b>
0.8 x 6 x 40	<b>508-3551</b>	<b>508-3439</b>	<b>508-3447</b>	<b>508-3446</b>	<b>508-3454</b>	<b>21.90</b>	<b>508-3455</b>	<b>508-3456</b>	<b>508-3457</b>	<b>18.75</b>
1 x 4 x 40	<b>508-3552</b>	<b>508-3440</b>	<b>508-3458</b>	<b>508-3459</b>	<b>508-3460</b>	<b>12.90</b>	<b>508-3461<sup>2</sup></b>	<b>508-3462</b>	<b>508-3463</b>	<b>11.25</b>
1 x 6 x 40	<b>508-3553</b>	<b>508-3441</b>	<b>508-3492</b>	<b>508-3494</b>	<b>508-3464<sup>1</sup></b>	<b>18.70</b>	<b>508-3465<sup>1,2</sup></b>	<b>508-3466</b>	<b>508-3467</b>	<b>16.10</b>
2 x 6 x 40	<b>508-3554</b>	<b>508-3442</b>	<b>508-3468</b>	<b>508-3469</b>	<b>508-3470</b>	<b>28.35</b>	<b>508-3471</b>	<b>508-3472</b>	<b>508-3473</b>	<b>24.65</b>
2 x 12 x 40	<b>508-3555</b>	<b>508-3443</b>	<b>508-3478</b>	<b>508-3479</b>	<b>508-3474</b>	<b>52.90</b>	<b>508-3475</b>	<b>508-3476</b>	<b>508-3477</b>	<b>45.85</b>
ROUND	Emerald (120 grit) Item#	Gold (180 grit) Item#	Lt. Brown (300 grit) Item#	Orange (400 grit) Item#	Brown (600 grit) Item#	Each	Blue (800 grit) Item#	White (1000 grit) Item#	Red (1200 grit) Item#	Each
2.35 x 30	<b>508-3556</b>	<b>508-3444</b>	<b>508-3493</b>	<b>508-3489</b>	<b>508-3480</b>	<b>\$19.95</b>	<b>508-3481</b>	<b>508-3482</b>	<b>508-3483</b>	<b>\$17.00</b>
3 x 30	<b>508-3557</b>	<b>508-3445</b>	<b>508-3490</b>	<b>508-3491</b>	<b>508-3485<sup>1</sup></b>	<b>19.95</b>	<b>508-3486<sup>1</sup></b>	<b>508-3487</b>	<b>508-3488</b>	<b>17.00</b>

<sup>1</sup>Supplied with ULTRAMAX DF/SF. <sup>2</sup>Supplied with ULTRAMAX UM-1200.

**Standard Super Ceramic Stones**

Choose from flat and round sizes. For optimal performance, use in lengths of 30–40mm or 60–100mm.

FLAT	Emerald (120 grit) Item#	Gold (180 grit) Item#	Lt. Brown (300 grit) Item#	Orange (400 grit) Item#	Brown (600 grit) Item#	Blue (800 grit) Item#	White (1000 grit) Item#	Red (1200 grit) Item#	Each
0.5 x 1 x 100	<b>351-0325</b>	<b>351-0326</b>	<b>351-0327</b>	<b>351-0328</b>	<b>351-0329</b>	<b>351-0330</b>	<b>351-0331</b>	<b>351-0332</b>	<b>\$9.95</b>
0.5 x 4 x 100	<b>351-0301</b>	<b>351-0209</b>	<b>351-0204</b>	<b>351-0206</b>	<b>351-0201</b>	<b>351-0226</b>	<b>351-0227</b>	<b>351-0228</b>	<b>20.90</b>
0.5 x 6 x 100	<b>351-0302</b>	<b>351-0003</b>	<b>351-0207</b>	<b>351-0208</b>	<b>351-0202</b>	<b>351-0229</b>	<b>351-0230</b>	<b>351-0231</b>	<b>31.45</b>
0.5 x 10 x 100	<b>351-0303</b>	<b>351-0216</b>	<b>351-0221</b>	<b>351-0222</b>	<b>351-0203</b>	<b>351-0232</b>	<b>351-0233</b>	<b>351-0234</b>	<b>41.25</b>
0.8 x 4 x 100	<b>351-0304</b>	<b>351-0219</b>	<b>351-0235</b>	<b>351-0236</b>	<b>351-0004</b>	<b>351-0005</b>	<b>351-0010</b>	<b>351-0015</b>	<b>20.90</b>
0.8 x 6 x 100	<b>351-0305</b>	<b>351-0018</b>	<b>351-0237</b>	<b>351-0238</b>	<b>351-0019</b>	<b>351-0020</b>	<b>351-0025</b>	<b>351-0030</b>	<b>31.45</b>
0.8 x 10 x 100	<b>351-0306</b>	<b>351-0223</b>	<b>351-0239</b>	<b>351-0240</b>	<b>351-0031</b>	<b>351-0032</b>	<b>351-0033</b>	<b>351-0034</b>	<b>41.25</b>
1 x 1 x 100	<b>351-0333</b>	<b>351-0334</b>	<b>351-0335</b>	<b>351-0336</b>	<b>351-0337</b>	<b>351-0338</b>	<b>351-0339</b>	<b>351-0340</b>	<b>9.95</b>
1 x 2 x 100	<b>351-0307</b>	<b>351-0274</b>	<b>351-0275</b>	<b>351-0276</b>	<b>351-0277</b>	<b>351-0278</b>	<b>351-0279</b>	<b>351-0280</b>	<b>12.00</b>
1 x 4 x 100	<b>351-0308</b>	<b>351-0224</b>	<b>351-0241</b>	<b>351-0242</b>	<b>351-0036</b>	<b>351-0035</b>	<b>351-0040</b>	<b>351-0045</b>	<b>20.90</b>
1 x 6 x 100	<b>351-0309</b>	<b>351-0048</b>	<b>351-0243</b>	<b>351-0244</b>	<b>351-0049</b>	<b>351-0050</b>	<b>351-0055</b>	<b>351-0060</b>	<b>31.45</b>
1 x 10 x 100	<b>351-0310</b>	<b>351-0266</b>	<b>351-0245</b>	<b>351-0246</b>	<b>351-0079</b>	<b>351-0080</b>	<b>351-0085</b>	<b>351-0090</b>	<b>41.25</b>
1.5 x 2.5 x 100	<b>351-0097</b>	<b>351-0098</b>	<b>351-0247</b>	<b>351-0248</b>	<b>351-0091</b>	<b>351-0092</b>	<b>351-0093</b>	<b>351-0094</b>	<b>20.90</b>
1.5 x 4 x 100	<b>351-0311</b>	<b>351-0267</b>	<b>351-0249</b>	<b>351-0250</b>	<b>351-0109</b>	<b>351-0110</b>	<b>351-0115</b>	<b>351-0120</b>	<b>31.13</b>
1.5 x 6 x 100	<b>351-0312</b>	<b>351-0268</b>	<b>351-0251</b>	<b>351-0252</b>	<b>351-0124</b>	<b>351-0125</b>	<b>351-0130</b>	<b>351-0135</b>	<b>47.30</b>
1.5 x 10 x 100	<b>351-0313</b>	<b>351-0269</b>	<b>351-0253</b>	<b>351-0254</b>	<b>351-0136</b>	<b>351-0137</b>	<b>351-0138</b>	<b>351-0139</b>	<b>62.45</b>
2 x 4 x 100	<b>351-0314</b>	<b>351-0161</b>	<b>351-0255</b>	<b>351-0256</b>	<b>351-0154</b>	<b>351-0155</b>	<b>351-0160</b>	<b>351-0165</b>	<b>41.25</b>
2 x 6 x 100	<b>351-0315</b>	<b>351-0162</b>	<b>351-0257</b>	<b>351-0258</b>	<b>351-0169</b>	<b>351-0170</b>	<b>351-0175</b>	<b>351-0180</b>	<b>62.90</b>
2 x 10 x 100	<b>351-0316</b>	<b>351-0163</b>	<b>351-0259</b>	<b>351-0260</b>	<b>351-0181</b>	<b>351-0182</b>	<b>351-0183</b>	<b>351-0184</b>	<b>82.53</b>
ROUND	Emerald (120 grit) Item#	Gold (180 grit) Item#	Lt. Brown (300 grit) Item#	Orange (400 grit) Item#	Brown (600 grit) Item#	Blue (800 grit) Item#	White (1000 grit) Item#	Red (1200 grit) Item#	Each
3 x 50mm	<b>351-0317</b>	<b>351-0157</b>	<b>351-0196</b>	<b>351-0197</b>	<b>351-0198</b>	<b>351-0200</b>	<b>351-0205</b>	<b>351-0210</b>	<b>\$20.45</b>
3/32" x 2"	<b>351-0318</b>	<b>351-0156</b>	<b>351-0261</b>	<b>351-0262</b>	<b>351-0263</b>	<b>351-0264</b>	<b>351-0265</b>	<b>351-0159</b>	<b>18.54</b>
1/8" x 2"	<b>351-0319</b>	<b>351-0158</b>	<b>351-0217</b>	<b>351-0218</b>	<b>351-0211</b>	<b>351-0212</b>	<b>351-0213</b>	<b>351-0214</b>	<b>25.65</b>

## A Super Ceramic Diamond Stones

An effective combination of ceramic fibers and diamond particles.

SCD Stones combine ceramic fibers with multiple layers of evenly distributed diamond particles to provide continuous cutting action for finishing hardened steel and carbide tools. SCD Stones won't load like plated diamond files, are more efficient than diamond compounds and are easily shaped. Unlike ceramic stones, which polish only on an angle at their tips, SCD Stones cut and polish flat to a surface, allowing fast and accurate polishing in open areas. Perfect for polishing ribs, hard-to-reach slots and sidewalls and milled or EDM flat surfaces. Their strong, durable ceramic fiber construction makes them ideal for use in ultrasonic polishers. Also effective when used in mechanical profilers and by hand. Available in flat and round shapes in three color-coded grits.

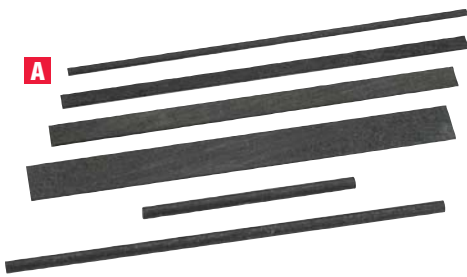

Shape	Size (mm)	Black	Gray	Green	EACH Prices	
		(200 grit) Item#	(400 grit) Item#	(600 grit) Item#	1-4	5+*
Flat	1 x 2 x 100	<b>351-0797</b>	<b>351-0798</b>	<b>351-0799</b>	<b>\$14.50</b>	<b>\$13.05</b>
	1 x 4 x 100	<b>351-0800</b>	<b>351-0801</b>	<b>351-0802</b>	<b>28.50</b>	<b>25.65</b>
	1 x 6 x 100	<b>351-0803</b>	<b>351-0804</b>	<b>351-0805</b>	<b>43.30</b>	<b>38.97</b>
	1 x 10 x 100	<b>351-0806</b>	<b>351-0807</b>	<b>351-0808</b>	<b>56.90</b>	<b>51.21</b>
Round	3 x 50	<b>351-0809</b>	<b>351-0810</b>	<b>351-0811</b>	<b>39.30</b>	<b>35.37</b>
	3 x 100	<b>351-0812</b>	<b>351-0813</b>	<b>351-0814</b>	<b>78.60</b>	<b>70.74</b>

\*Quantity discount for orders of one item# only, not assorted.

## B, C Resin-Bonded Diamond Stones – For ULTRAMAX® units

These stones contain precision-graded diamond particles uniformly distributed in a unique resin bond for great resilience, combining the cutting capabilities of diamond with the flex and breakage resistance of resin. Will not scratch surfaces. Great for fine finishing. Can be used on EDM surfaces as a final step. For use with clamp tool holders (see p. 84). Use 3 x 6 x 22mm size with holder #508-3510 in DF/SF UF-9700 handpiece or holder #500-0110 in UM-1200 handpiece. Use 3 x 10 x 22mm size with holder #508-3511 in DF/SF UF-9700 handpiece or holder #500-0110 in UM-1200 handpiece.

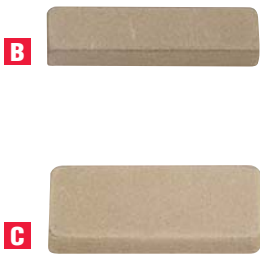

Shape	Size (mm)	200 grit Item#	320 grit Item#	500 grit Item#	Each
<b>B. Flat</b>	3 x 6 x 22	<b>508-3400<sup>1</sup></b>	<b>508-3402<sup>1</sup></b>	<b>508-3404</b>	<b>\$66.10</b>
<b>C. Flat</b>	3 x 10 x 22	<b>508-3406</b>	<b>508-3408</b>	<b>508-3410</b>	<b>85.00</b>

<sup>1</sup>Supplied with ULTRAMAX DF/SF.

## D - G Brass and Wood Laps – For ULTRAMAX® units

For fine and ultra-fine polishing with diamond compound. Use to polish intricate or flat surfaces. All can be shaped with a diamond file or stone. Brass laps are excellent for polishing narrow slots. Use these tools with the appropriate clamp tool holder (see chart below and p. 84).



**E** Brass laps can be cut and shortened at dotted line.

Material	Size (mm)	Item#	Pkg. of 5
<b>D. Brass</b>	3 x 60 round	<b>508-3346</b>	<b>\$8.20</b>
<b>E. Brass</b>	2 x 5 x 60 flat	<b>508-3347</b>	<b>9.25</b>
<b>F. Extra-Hard Wood</b>	3 x 30 round	<b>508-3349<sup>1</sup></b>	<b>19.45</b>
<b>G. Extra-Hard Wood</b>	3.2 x 6 x 30 flat	<b>508-3351<sup>1</sup></b>	<b>20.00</b>

<sup>1</sup>Supplied with ULTRAMAX DF/SF.



Lap#	Use with DF/SF Holder#	Use with UM-1200 Holder#
<b>508-3346</b>	<b>508-3512</b>	<b>500-0109</b>
<b>508-3347</b>	<b>508-3506</b>	<b>500-0132</b>
<b>508-3349</b>	<b>508-3512</b>	<b>500-0109</b>
<b>508-3351</b>	<b>508-3514</b>	<b>500-0133</b>



**Gesswein® Finishing Stones – For UF-9700 handpiece**

Rely on the dependable quality of our popular finishing stones, sized especially for use with your UF-9700 ultrasonic handpiece. Special close thickness tolerance (+0 -.004") ensures proper fit in the clamp tool holder. Use holder #508-3504 for 1.5 x 6 x 25mm stones and #508-3511 for 3 x 12 x 22mm stones (see p. 84). Stones are listed from hardest to softest. (See pp. 2–3 for more information on the various stone types and additional sizes.) **Do not use in UM-1200 ultrasonic handpiece supplied with ULTRAMAX UM-1200.**

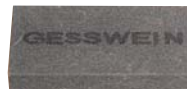
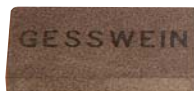

**RA**

Made of aluminum oxide in a special breakdown-resistant resin bond. They hold their shape and do not scratch or load. For use on hard-to-reach areas such as slots and ribs. May also be used to remove EDM scale.

Size (mm)	Style	Grit	Item#	Pkg. of 10
1.5 x 6 x 25	R-21	220	<b>509-0321</b>	<b>\$7.25</b>
	R-31	320	<b>509-0331</b>	<b>7.25</b>
	R-41	400	<b>509-0341</b>	<b>7.25</b>
	R-61	600	<b>509-0361</b>	<b>7.25</b>
3 x 12 x 22	R-23	220	<b>509-0323</b>	<b>9.35</b>
	R-33	320	<b>509-0333</b>	<b>9.35</b>
	R-43	400	<b>509-0343</b>	<b>9.35</b>
	R-63	600	<b>509-0363</b>	<b>9.35</b>

**Moldmaker**

Silicon carbide abrasive. Easy to shape for contours. Nonloading and fast-cutting with rapid breakdown.

Size (mm)	Style	Grit	Item#	Pkg. of 10
1.5 x 6 x 25	M-21	220	<b>509-0221</b>	<b>\$7.25</b>
	M-31	320	<b>509-0231</b>	<b>7.25</b>
	M-41	400	<b>509-0241</b>	<b>7.25</b>
	M-61	600	<b>509-0261</b>	<b>7.25</b>
3 x 12 x 22	M-23	220	<b>509-0223</b>	<b>9.35</b>
	M-33	320	<b>509-0233</b>	<b>9.35</b>
	M-43	400	<b>509-0243</b>	<b>9.35</b>
	M-63	600	<b>509-0263</b>	<b>9.35</b>

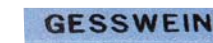
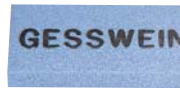
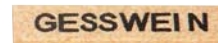

**EDM**

Made of aluminum oxide for fast removal of EDM scale. Cut fast and hold their shape very well. Quickly remove bumps and high spots without distorting surface.

Size (mm)	Style	Grit	Item#	Pkg. of 10
1.5 x 6 x 25	E-11	180	<b>509-2111</b>	<b>\$7.25</b>
	E-31	320	<b>509-2131</b>	<b>7.25</b>
	E-41	400	<b>509-2141</b>	<b>7.25</b>
	E-61	600	<b>509-2161</b>	<b>7.25</b>
3 x 12 x 22	E-13	180	<b>509-2113</b>	<b>9.35</b>
	E-33	320	<b>509-2133</b>	<b>9.35</b>
	E-43	400	<b>509-2143</b>	<b>9.35</b>
	E-63	600	<b>509-2163</b>	<b>9.35</b>

**EDM Blue**

Made of aluminum oxide. Superior for removing hard EDM scale. Nonloading and hold their shape well.

Size (mm)	Style	Grit	Item#	Pkg. of 10
1.5 x 6 x 25	B-11	180	<b>509-1011</b>	<b>\$7.25</b>
	B-31	320	<b>509-1031</b>	<b>7.25</b>
	B-41	400	<b>509-1041</b>	<b>7.25</b>
	B-61	600	<b>509-1061</b>	<b>7.25</b>
3 x 12 x 22	B-13	180	<b>509-1013</b>	<b>9.35</b>
	B-33	320	<b>509-1033</b>	<b>9.35</b>
	B-43	400	<b>509-1043</b>	<b>9.35</b>
	B-63	600	<b>509-1063</b>	<b>9.35</b>



**Oil-Treated**

White aluminum oxide abrasive soaked in oil solution. Hard, fast-cutting and nonloading.

Size (mm)	Style	Grit	Item#	Pkg. of 10
1.5 x 6 x 25	T-31	320	<b>509-0431</b>	<b>\$7.25</b>
	T-41	400	<b>509-0441</b>	<b>7.25</b>
3 x 12 x 22	T-33	320	<b>509-0433</b>	<b>9.35</b>
	T-43	400	<b>509-0443</b>	<b>9.35</b>

**Diemaker**

An aluminum oxide abrasive for general purpose stoning on all types of steel. Fast-cutting and nonloading. Semihard with moderate breakdown rate.

Size (mm)	Style	Grit	Item#	Pkg. of 10
1.5 x 6 x 25	D-31	320	<b>509-0031</b>	<b>\$7.25</b>
	D-41	400	<b>509-0041</b>	<b>7.25</b>
	D-61	600	<b>509-0061</b>	<b>7.25</b>
3 x 12 x 22	D-33	320	<b>509-0033</b>	<b>9.35</b>
	D-43	400	<b>509-0043</b>	<b>9.35</b>
	D-63	600	<b>509-0063</b>	<b>9.35</b>

## POWER HAND<sup>®</sup> 2X

**The most versatile finishing system in the industry, offering rotary, profiling and belt sanding action!**

With its broad selection of modular controllers, handpieces and accessories, the Power Hand 2X 30V DC micromotor system delivers precision finishing, deburring and polishing results. Completely portable, it lets the user repair molds and dies without taking them out of the press – a huge time-saver.

To obtain the Power Hand 2X combination that best suits your needs, start by selecting the appropriate controller type: Dual, Standard or Marathon. The Dual Controller runs two handpieces at once, independently of each other. Permits two operators to work on completely separate jobs at the same time. The Standard Controller has two handpiece outlets but runs only one at a time. Allows quick changing from one handpiece to the other at the flip of a switch, eliminating constant

handpiece and tool changes. The economical Marathon Controller delivers less torque than the other two controllers and has one handpiece outlet. A perfect selection for light work that requires only one handpiece operation. Each controller includes built-in safety features to protect handpiece motors, feedback circuitry to maintain torque and speed as load increases, forward/reverse switches and optional rheostats to control speed manually.

After selecting your controller, choose from straight and angle rotary handpieces, reciprocating profilers, a side-to-side profiler and a belt sander. Lightweight yet sturdy, all are engineered to provide true-running, vibration-free operation. Each includes a self-contained air-cooled motor and a flexible telephone-type power cord. Rotary handpieces also include a quick-

tool-change mechanism. Slimline rotaries are designed for delicate applications.

To further enhance the versatility of your Power Hand 2X, there are additional options. You can add the 4:1 Reduction Gear to rotary handpiece motors to increase torque by four times. Or you can mix and match specialized heads with motors (see p. 95 for compatibility chart).

### Power Hand 2X component selection:

- Three controllers
- Seven straight (five standard, two slimline) and two angle rotaries
- Two reciprocating profilers
- One side-to-side profiler
- One belt sander
- One 4:1 reduction gear
- Separate motors and handpiece heads



**A**

### **A** Dual Controller – Dual Handpiece Operation.

The Dual Controller allows two people to operate Power Hand 2X handpieces at the same time. Each handpiece output station runs independently with separate speed controls and forward/reverse switches. Optional variable foot rheostats for each output station can be added. Includes a convenient handpiece rest on top of the controller and a handle for easy portability. Available in 115V or 230V AC, 50/60Hz. Output voltage: 3-30V DC (continuously variable). Measures only 8"D x 8<sup>1</sup>/<sub>4</sub>"W x 7"H. Weighs 9 lbs. Made in Japan.

#### Features:

- Positive motor overload cutoff switch to protect handpiece motors
- Thermal protection sensor to protect controller from overheating
- Advanced electronic feedback circuitry to provide high torque to handpieces while maintaining constant speed
- Convenient carrying handle and handpiece rest on top of controller

Description	Item#	Each
Dual Controller, 115V	<b>510-2100</b>	<b>\$399.00</b>
Dual Controller, 230V	<b>510-2110</b>	<b>399.00</b>



**B**

### **B, C** Standard Controller – Single Handpiece Operation.

The Standard Controller is compact and lightweight with two handpiece output stations. Although only one station can be used at a time, you can change from one handpiece to another at the flip of a switch, eliminating time-consuming tool changes. Speeds are adjusted by the slide rheostat or optional variable foot rheostat, and handpieces can be operated in either forward or reverse direction. Available in 115V or 230V AC, 50/60Hz. Output voltage: 3-30V DC (continuously variable). Measures only 7<sup>3</sup>/<sub>4</sub>"D x 3<sup>3</sup>/<sub>8</sub>"W x 5<sup>3</sup>/<sub>4</sub>"H. Weighs 5.5 lbs. Made in Japan.

#### Features:

- Positive motor overload cutoff switch to protect handpiece motors
- Thermal protection sensor to protect controller from overheating
- Advanced electronic feedback circuitry to provide high torque to handpieces while maintaining constant speed
- Built-in handpiece holder and convenient retractable handle



**C**

Description	Item#	Each
<b>B.</b> Standard Controller, 115V	<b>510-3000</b>	<b>\$330.00</b>
Standard Controller, 230V	<b>510-3010</b>	<b>330.00</b>
<b>C.</b> Replacement HP Holder	510-3130	9.95

**A Marathon Handy 700 Micromotor System**

The Handy 700 system features an advanced controller and a 50,000rpm, 230W brushless rotary handpiece for incredible power—even at low speeds! Also accommodates all 13 Power Hand 2X brush-type micromotor handpieces (see pp. 90-94).

Provides ample torque at all times to ensure fast and smooth metal removal. Ideal for a variety of applications, including grinding, finishing and polishing. Use with Power Hand 2X handpieces for profile polishing, belt sanding and angle-rotary operations or rotary finishing tasks that require normal torque.

In addition to Handy 700 controller with integral carrying handle and BH-60 handpiece with quick-tool-change mechanism, system includes 1/8" or 3/32" collet, variable-speed foot rheostat, handpiece cradle rest, detachable handpiece holder and replacement fuse. Backed by a two-year handpiece warranty. CE approved.

**Features:**

- Incredible power—even at low speeds
- Full compatibility with Power Hand 2X brush-type micromotor handpieces
- Dial or foot rheostat speed control
- Auto-cruise function for fixed-speed operation with foot rheostat
- Easy-to-read digital speed display for precise speed and torque settings
- Maximum handpiece torque mode
- Forward/reverse rotation
- Error-checking/troubleshooting system with digital display
- Overload protection

**Specifications:**

**Handy 700 Controller**

Electrical 100–120V, 40W, 50/60Hz  
 Dimensions 5 3/8"W x 9 1/16"D x 7 1/16"H  
 Net Wt. 6 lbs.

**BH-60 Handpiece**

Speed Range 1,000–50,000rpm  
 Max. Power 230W  
 Max. Torque 7.8 N-cm  
 Collet Size 1/8" or 3/32"  
 Dimensions 6 5/16"L x 1 1/16" to 3/4" dia.  
 Net Wt. 8.4 oz.

Description	Item#	Each
Handy 700, 1/8" collet	<b>510-2925</b>	<b>\$995.00</b>
Handy 700, 3/32" collet	<b>510-2920</b>	<b>995.00</b>



**B Marathon Micromotor System**

This extremely affordable rotary micromotor system performs a wide range of grinding, deburring and polishing operations. Includes compact controller, lightweight 35,000rpm rotary handpiece, 1/8" or 3mm collet, variable-speed foot rheostat, handpiece cradle rest and safety glasses.

Controller features a voltage selector switch, dial speed control, forward/reverse handpiece direction switch and motor overload cutoff switch. Accommodates our full line of Power Hand 2X handpieces. Electrical: 110/220V, 50/60Hz. Output voltage: 0–30V DC (continuously variable). Measures 4 1/2"W x 5 3/4"D x 3 3/4"H. Weighs 2.6 lbs. Handpiece features a well-balanced ergonomic design that fits in your hand like a pen, convenient quick-tool-change mechanism and flexible phone-type cord. Max. operating speed: 35,000rpm. Measures 6"L x 1" to 5/8" dia. Weighs 7.5 oz.

Description	Item#	Each
<b>B.</b> Marathon System with 1/8" Collet	<b>510-2945</b>	<b>\$299.00</b>
Marathon System with 3mm Collet	<b>510-2970</b>	<b>299.00</b>
Marathon Controller only	<b>510-2960</b>	<b>129.00</b>
Marathon Variable-Speed Foot Rheostat only	<b>510-2940</b>	<b>68.00</b>



**C - F POWER/HAND®2X Accessories**

Description	Item#	Each
<b>C.</b> Variable-Speed Foot Rheostat (for all except Handy 700)	<b>510-2995</b>	<b>\$95.00</b>
<b>D.</b> On/Off Foot Switch (for Dual and Standard Controllers)	<b>510-3105</b>	<b>45.00</b>
<b>E.</b> 6' Handpiece Extension Cord	<b>510-1120</b>	<b>46.00</b>
<b>F.</b> Handpiece Cradle Rest	<b>510-1130</b>	<b>14.60</b>



## A, B POWER/HAND® 2X Reciprocating Profilers

Choose from three lightweight reciprocating handpieces with powerful 30V DC air-cooled motors and sealed bearings. Use for polishing flat surfaces, deburring, filing, stoning, scraping, lapping and draw-stoning deep cavities. They operate with minimal vibration to reduce fatigue and have flexible power cords for easy reach. Special V-shaped chucking system firmly secures a wide variety of abrasives and other tools (see p. 212 for steel files). Reciprocating stroke lengths are adjustable.

Specifications:	Z-2X	Z-6X	SZX
Strokes per second			
Dual or Single Controller*	0-117	0-70	0-133
Standard Controller	29-117	15-70	32-133
Length of stroke	0-2.0mm	0-6.0mm	0-1.6mm**
Maximum Stoppage Torque			
Dual Controller, ft.-lbs./N-m	0.056/0.076	0.056/0.076	0.054/0.073
Standard Controller, ft.-lbs./N-m	0.048/0.065	0.048/0.065	0.047/0.064
Single Controller, ft.-lbs./N-m	0.053/0.072	0.053/0.072	0.053/0.072
Maximum shaft output (W/sec.)			
Dual Controller	50	50	36
Standard Controller	32.5	32.5	—
Single Controller	33.8	33.8	33
Weight without power cord	24 oz.	24 oz.	10 oz.

\*Or Standard Controller with variable-speed foot rheostat

\*\*Increases with tool length

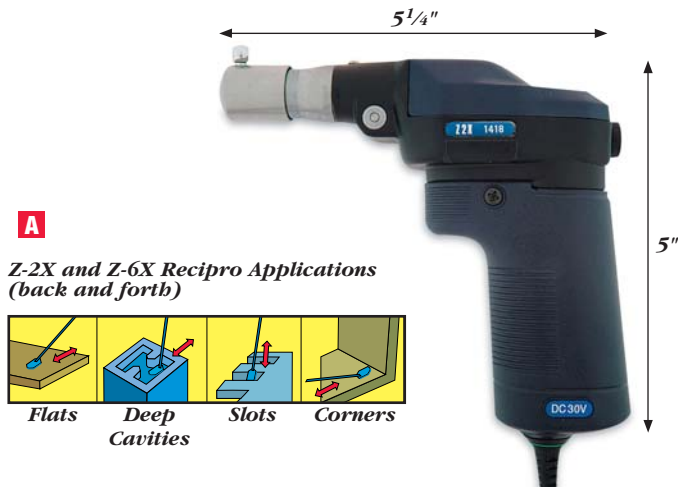

**Z-2X and Z-6X Recipro Applications (back and forth)**

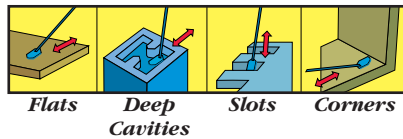

**SZX Profiler Applications (side to side)**

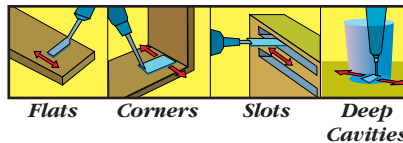

### A Z-2X and Z-6X Reciprocating Profilers

Both Z-2X and Z-6X provide standard back-and-forth reciprocating action with choice of speeds and stroke lengths (see chart). They hold 1.5 to 6.35mm (1/4") diameter tools as well as 4mm or 6mm threaded Ultramax ultrasonic tools (see pp. 82-83) with appropriate adapters (see below) and clamp tool holders (see p. 84). Secured tools can float freely and be fixed at any position through 360°. Comfortable grips allow prolonged use.

Description	Item#	Each
A. Z-2X	<b>510-2150</b>	<b>\$795.00</b>
Z-6X	<b>510-2160</b>	<b>795.00</b>

### B SZX Side-to-Side Profiler

Provides unique side-to-side reciprocating action with adjustable stroke. Perfect for polishing base areas in deep cavities, corners and deep slots. Helps eliminate rounding of sharp corners. Prevents bottoming out in blind holes. Holds 1.5 to 5mm (3/16") diameter tools. Comfortable grip allows prolonged use.

Description	Item#	Each
SZX	<b>510-2245</b>	<b>\$749.00</b>

### Safety Recommendations – For Z-2X, Z-6X and SZX Profilers.

Prolonged use of vibrating or reciprocating tools may result in vibration-induced circulation problems in the hands. Always follow safe operating procedures. Using hand protection (i.e., insulated gloves) and taking frequent breaks can help minimize but not guarantee against injury. Operating these types of tools in cold weather or with a tight grip will reduce the period of operation before risking potential injury. Individuals with a tendency to suffer from poor circulation, frequently cold fingers or itchy hands should closely monitor the condition of their hands. If symptoms appear, seek medical advice immediately.



**A - D Tool Holders for Z-2X, Z-6X and SZX**

These 3mm shank holders are designed to hold precut PSA felt and sandpaper pads to make your reciprocating handpieces more versatile. You can cut your own abrasives, such as diamond foil and diamond film (see p. 161), to fit the holder pads.

Style	Dimensions (mm)	Item#	Each
<b>A.</b> Holder/Steel Lap Tool	5 x 40	<b>510-0555</b>	<b>\$13.75</b>
	5 x 65	<b>510-0400</b>	<b>18.90</b>
<b>B.</b> Fixed Holder	10 x 20 x 40	<b>510-0560</b>	<b>4.95</b>
	10 x 20 x 65	<b>510-0410</b>	<b>4.95</b>
<b>C.</b> Free Holder with 180° swivel	10 x 20 x 80	<b>510-0420</b>	<b>14.50</b>
<b>D.</b> 40°-angle Rod (holds any of above to access tight cavities and corners)	12 x 90	<b>510-0430</b>	<b>19.95</b>



**E, F PSA Sandpaper and Felt Pads**

Precut waterproof SiC sandpaper pads, 10 x 20mm, with pressure-sensitive adhesive backing. Precut PSA felt pads can be charged with diamond compound. Excellent for use on flat surfaces. For use with Z-2X, Z-6X and SZX handpiece holders (see previous page).

Description	Grit	Item#	Pkg. of 10
<b>E.</b> Sandpaper Pad	180	<b>510-0200</b>	<b>\$4.60</b>
	240	<b>510-0210</b>	<b>4.60</b>
	320	<b>510-0220</b>	<b>4.60</b>
	400	<b>510-0230</b>	<b>4.60</b>
	600	<b>510-0240</b>	<b>4.60</b>
<b>F.</b> Felt Pad	-	<b>510-0300</b>	<b>5.75</b>

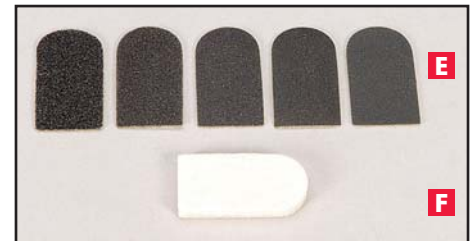

**G POWER/HAND<sup>2</sup>X BZX Belt Sander**

Ideal for a wide variety of precision finishing applications. Use for deburring, removing EDM and machine tool marks and sanding flat and curved surfaces and narrow slots. Operates with minimal vibration and has flexible power cord for easy reach. Supplied with straight and 45°-angle arms for 6 and 8mm wide abrasive belts. Arms are spring-loaded for rapid belt changes. Belt speed is 3-12 meters/sec. (10-39 feet/sec.) with Standard Controller, 0-12 meters/sec. with Dual or Single Controller or Standard Controller with optional variable foot rheostat. Weighs 16 oz.

Description	Item#	Each
<b>G.</b> BZX Belt Sander	<b>510-2130</b>	<b>\$750.00</b>
Bearing #201	510-3096	13.20
Bearing #205	510-3092	13.20
Armature only	510-3061	157.60

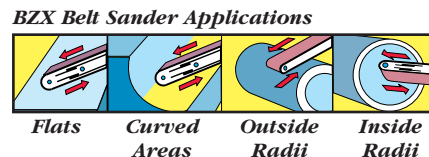
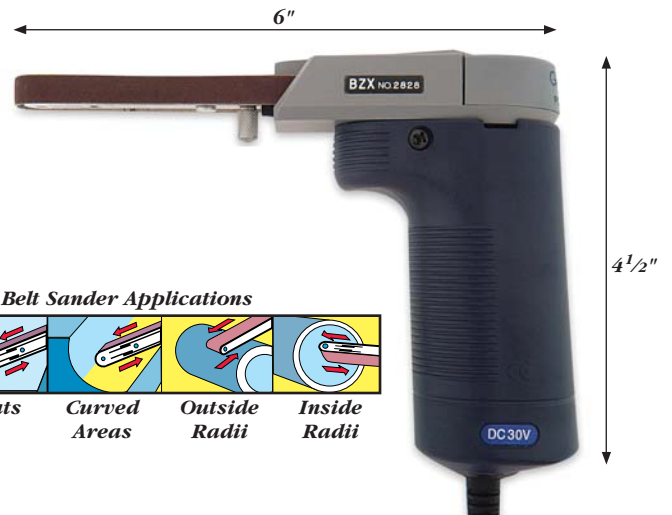

**H, I, J Sanding Arms for BZX**

Description	Item#	Each
<b>H.</b> Optional Straight Arm (for 4mm belts)	<b>510-0494</b>	<b>\$88.50</b>
<b>I.</b> 45°-Angle Arm (for 6 and 8mm belts)	510-0495	159.00
<b>J.</b> Straight Arm (for 6 and 8mm belts)	510-0496	126.50



**K Sanding Belts for BZX**

Aluminum oxide abrasive belts specially made for use with our Power Hand 2X BZX Belt Sander. Belts fit on either straight or 45°-angle arms.

Size	80 Grit Item#	120 Grit Item#	180 Grit Item#	320 Grit Item#	Pkg. of 10
4mm	<b>510-0500</b>	<b>510-0505</b>	<b>510-0510</b>	<b>510-0515</b>	<b>\$16.75</b>
6mm	<b>510-0520</b>	<b>510-0525</b>	<b>510-0527</b>	<b>510-0530</b>	<b>16.75</b>
8mm	<b>510-0535</b>	<b>510-0540</b>	<b>510-0545</b>	<b>510-0550</b>	<b>16.75</b>



## Straight Rotary Applications

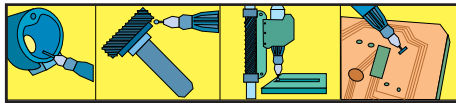

**Polishing Finishing Deburring Repairs**  
**Gears**

## POWER/HAND<sup>2</sup>X Straight Rotary Handpieces

Choose from six sturdy, true-running, well-balanced handpieces with powerful 30V DC air-cooled motors. Improved motor design increases torque by 20% and increases airflow to keep handpieces cool. They operate without vibration and have flexible power cords for easy reach. Connect to Power Hand 2X or Ultramax DF controllers. All straight rotary handpieces have a quick-tool-change feature. Supplied with  $\frac{3}{32}$ " (2.35mm) and  $\frac{1}{8}$ " (3.2mm) collets, collet wrenches and replacement motor brushes.

Handpiece Specifications:	Z-08X	Z-15X	Z-20XS	Z-30X	Z-35XS	HP5-3	Z-55X
RPM Range							
Dual or Single Controller*	0-8,000	0-15,000	0-20,000	0-30,000	0-35,000	0-40,000	0-55,000
Standard Controller	800-8,000	1,500-15,000	2,000-20,000	3,000-30,000	3,500-35,000	4,000-40,000	5,500-55,000
Max. Shaft Output (W/sec.)							
Dual Controller	22.8	49	40.4	65.7	55.7	51.4	58.6
Standard Controller	22.6	44	38	54.8	50.9	46.0	47.7
Single Controller	33	33.8	28	32.2	37.9	32.0	25
Max. Stoppage Torque**							
Dual Controller, ft.-lbs./N-m	0.065/0.088	0.065/0.088	0.039/0.053	0.047/0.063	0.036/0.049	0.032/0.043	0.023/0.031
Standard Controller, ft.-lbs./N-m	0.065/0.088	0.058/0.078	0.038/0.051	0.041/0.055	0.032/0.043	0.029/0.039	0.020/0.027
Single Controller, ft.-lbs./N-m	0.053/0.071	0.053/0.072	0.033/0.045	0.032/0.044	0.025/0.034	0.024/0.030	0.012/0.016
Weight without power cord	9.5 oz.	9.5 oz.	8 oz.	9.5 oz.	8 oz.	7 oz.	6.5 oz.

\*Or Standard Controller with variable-speed foot rheostat

\*\*Measured in foot-pounds/Newton-meters



**A**

### **A Z-08X Highest-Torque Rotary Handpiece – 8,000rpm**

Designed to handle the toughest jobs. This workhorse has the highest torque rating. Use it for hand grinding, heavy deburring, cutting, polishing and finishing all types of material. Supplied with  $\frac{3}{32}$ " and  $\frac{1}{8}$ " collets; 3mm collet available separately (see p. 99). This two-piece handpiece, with Z-M08X motor, can be used with head attachments shown on pp. 96 and 97.

Description	Item#	Each
<b>A. Z-08X</b>	<b>510-2257</b>	<b>\$549.00</b>
Bearing #206	510-3074	13.20
Bearing #208	510-3072	13.20
Bearing #201	510-3087	13.20
Bearing #205	510-3073	13.20



**B**

### **B Z-15X High-Torque Rotary Handpiece – 15,000rpm**

The Z-15X is designed for especially tough jobs. Use it for hand grinding, heavy deburring, cutting, polishing and finishing all types of material. Supplied with  $\frac{3}{32}$ " and  $\frac{1}{8}$ " collets; 3mm collet available separately (see p. 99). This two-piece handpiece, with Z-M15X motor, can be used with head attachments shown on pp. 96 and 97.

Description	Item#	Each
<b>B. Z-15X</b>	<b>510-2270</b>	<b>\$480.00</b>
Bearing #206	510-3074	13.20
Bearing #208	510-3072	13.20
Bearing #201	510-3087	13.20
Bearing #205	510-3073	13.20



**C**

### **C Z-20XS Slimline Rotary Handpiece – 20,000rpm**

Small, lightweight one-piece handpiece improves balance to ensure better control and comfort. The Z-20XS is well-suited for continuous production use and heavy work. Supplied with  $\frac{3}{32}$ " and  $\frac{1}{8}$ " collets; 3mm collet available separately (see p. 99).

Description	Item#	Each
<b>C. Z-20XS</b>	<b>510-2277</b>	<b>\$475.00</b>
Bearing #206	510-3074	13.20
Bearing #208	510-3072	13.20
Bearing #201	510-3073	13.20
Bearing #205	510-3076	13.20

**A Z-30X General-Purpose Rotary Handpiece – 30,000rpm**

The Z-30X is our most popular handpiece. Use this all-around rotary for cutting and deburring with carbide, mounted diamond and stone points. Can be used for many operations, including polishing, drilling and grinding. Supplied with  $\frac{3}{32}$ " and  $\frac{1}{8}$ " collets; 3mm collet available separately (see p. 99). This two-piece handpiece, with Z-M30X motor, can be used with head attachments shown on pp. 97.

Description	Item#	Each
<b>A. Z-30X</b>	<b>510-2280</b>	<b>\$535.00</b>
Bearing #206	510-3074	13.20
Bearing #208	510-3072	13.20
Bearing #201	510-3087	13.20
Bearing #205	510-3073	13.20



**B Z-35XS Slimline Rotary Handpiece – 35,000rpm**

Small, lightweight one-piece handpiece improves balance to ensure better control and comfort. The Z-35XS is well-suited for continuous work, for general-purpose grinding and polishing with carbide burs. Supplied with  $\frac{3}{32}$ " and  $\frac{1}{8}$ " collets; 3mm collet available separately (see p. 99).

Description	Item#	Each
<b>B. Z-35XS</b>	<b>510-2287</b>	<b>\$525.00</b>
Bearing #206	510-3074	13.20
Bearing #208	510-3072	13.20
Bearing #201	510-3073	13.20
Bearing #205	510-3076	13.20

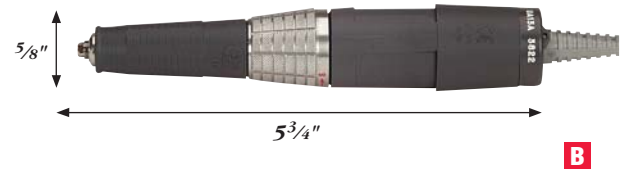

**C HP5-3 Rotary Handpiece – 40,000rpm**

A small, lightweight one-piece handpiece for high-speed grinding and polishing with carbide burs. Supplied with  $\frac{3}{32}$ " collet; 3mm and  $\frac{1}{8}$ " collets available separately (see p. 99).

Description	Item#	Each
<b>HP5-3</b>	<b>510-5105</b>	<b>\$228.00</b>

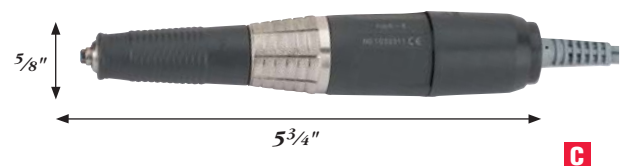

**D Z-55X High-Speed Rotary Handpiece – 55,000rpm**

The lightest, fastest and most comfortable of our straight rotaries. Features one-piece construction. A great choice for tools that perform best at high speeds. Use for precise deburring with carbide and diamond burs. Supplied with  $\frac{3}{32}$ " and  $\frac{1}{8}$ " collets; 3mm collet available separately (see p. 99).

Description	Item#	Each
<b>D. Z-55X</b>	<b>510-2290</b>	<b>\$499.00</b>
Bearing #206	510-3074	13.20
Bearing #208	510-3072	13.20
Bearing #201	510-3073	13.20
Bearing #205	510-3076	13.20

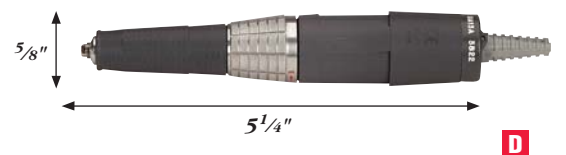

**A, B POWER/HAND<sup>2X</sup> Angle Rotary Handpieces**

These handpieces provide access to areas that conventional handpieces can't reach. Two different styles to choose from: right-angle (90°) and contra-angle (120°). Use for polishing flat and curved surfaces, deburring of die-cast parts and accessing awkward areas. These two-piece handpieces, each with Z-M15X motor, can be used with head attachments shown on pp. 96-97.

<b>Specifications:</b>	<b>RZ-15X (90°)</b>	<b>CZ-15X (120°)</b>
RPM Range		
Dual or Single Controller*	0-15,000	0-15,000
Standard Controller	1,500-15,000	1,500-15,000
Max. Shaft Output (W/sec.)		
Dual Controller	49	49
Standard Controller	44	44
Single Controller	33.8	33.8
Max. Stoppage Torque		
Dual Controller, ft.-lbs./N-m	0.065/0.088	0.065/0.088
Standard Controller, ft.-lbs./N-m	0.058/0.078	0.058/0.078
Single Controller, ft.-lbs./N-m	0.053/0.072	0.053/0.072
Overall Length	6¼"	6½"
Motor Diameter	1¼"	1¼"
Weight without power cord	13 oz.	13 oz.

\*Or Standard Controller with variable foot rheostat

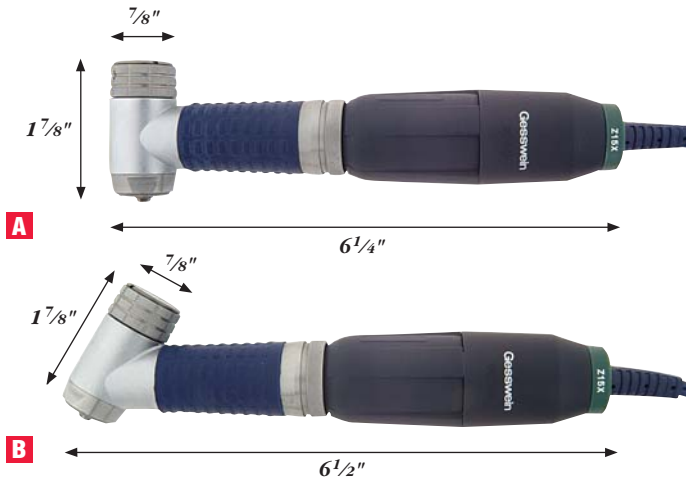

**A, B RZ-15X and CZ-15X Angle Rotary Handpieces – 15,000rpm**

Each model features two-piece construction and a high-torque Z-M15X motor to drive sandpaper, felt pads, mounted stones and brushes. Supplied with 3mm and 1/8" collets, collet wrenches, replacement motor brushes and tool accessory starter kit. Optional 3/32" collets available (see p. 99).

Description	Item#	Each
<b>A.</b> RZ-15X (90°)	<b>510-2120</b>	<b>\$645.00</b>
<b>B.</b> CZ-15X (120°)	<b>510-2225</b>	<b>645.00</b>

**C, D, E Disc Holders for Angle Rotaries – 3mm Shank**

Specially designed for Power Hand 2X angle handpieces and head attachments. Made of soft rubber to work well on flat or contoured surfaces. Precisely made to hold pre-cut abrasive and felt discs. Or use your own abrasives cut to size, such as diamond foil, diamond sheet or diamond film (see pp. 161, 165).



Size	Item#	Each
<b>C.</b> 11mm round	<b>510-0260</b>	<b>\$8.75</b>
<b>D.</b> 21mm round	<b>510-0265</b>	<b>8.75</b>
<b>E.</b> 31mm round	<b>510-0270</b>	<b>8.75</b>

**F - K Sandpaper and Felt Discs for Angle Rotaries**

Precut to fit our disc holders, these discs have pressure-sensitive adhesive backing. Use sandpaper for rough through intermediate finish; use felt for final finish of metal surfaces.

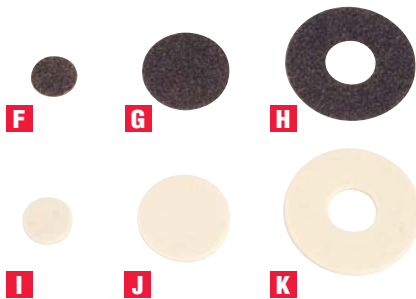

Sandpaper Discs	80 Grit Item#	120 Grit Item#	180 Grit Item#	320 Grit Item#	Pkg. of 10
<b>F.</b> 11mm round	<b>510-0600</b>	<b>510-0605</b>	<b>510-0610</b>	<b>510-0615</b>	<b>\$2.75</b>
<b>G.</b> 21mm round	<b>510-0620</b>	<b>510-0625</b>	<b>510-0630</b>	<b>510-0635</b>	<b>4.25</b>
<b>H.</b> 31mm round	<b>510-0640</b>	<b>510-0645</b>	<b>510-0650</b>	<b>510-0655</b>	<b>6.50</b>
Felt Discs	Item#			Pkg. of 10	
<b>I.</b> 11mm round	<b>510-0245</b>			<b>\$4.50</b>	
<b>J.</b> 21mm round	<b>510-0250</b>			<b>7.55</b>	
<b>K.</b> 31mm round	<b>510-0255</b>			<b>9.75</b>	



**POWER/HAND<sup>®</sup>2X Rotary Head Attachments and Motors**

**Mix and match heads and motors to create your own handpieces.**

Replace your Power Hand 2X head with another from our selection of head attachments, or purchase any of three motor assemblies and create your own handpiece. Either way, you choose the combination that best suits your needs. Each head features superb design for fast tool changes. Choose between an 8,000, 15,000 or 30,000rpm motor. For work requiring high torque at low speed, consider using our optional 4:1 Reduction Gear.

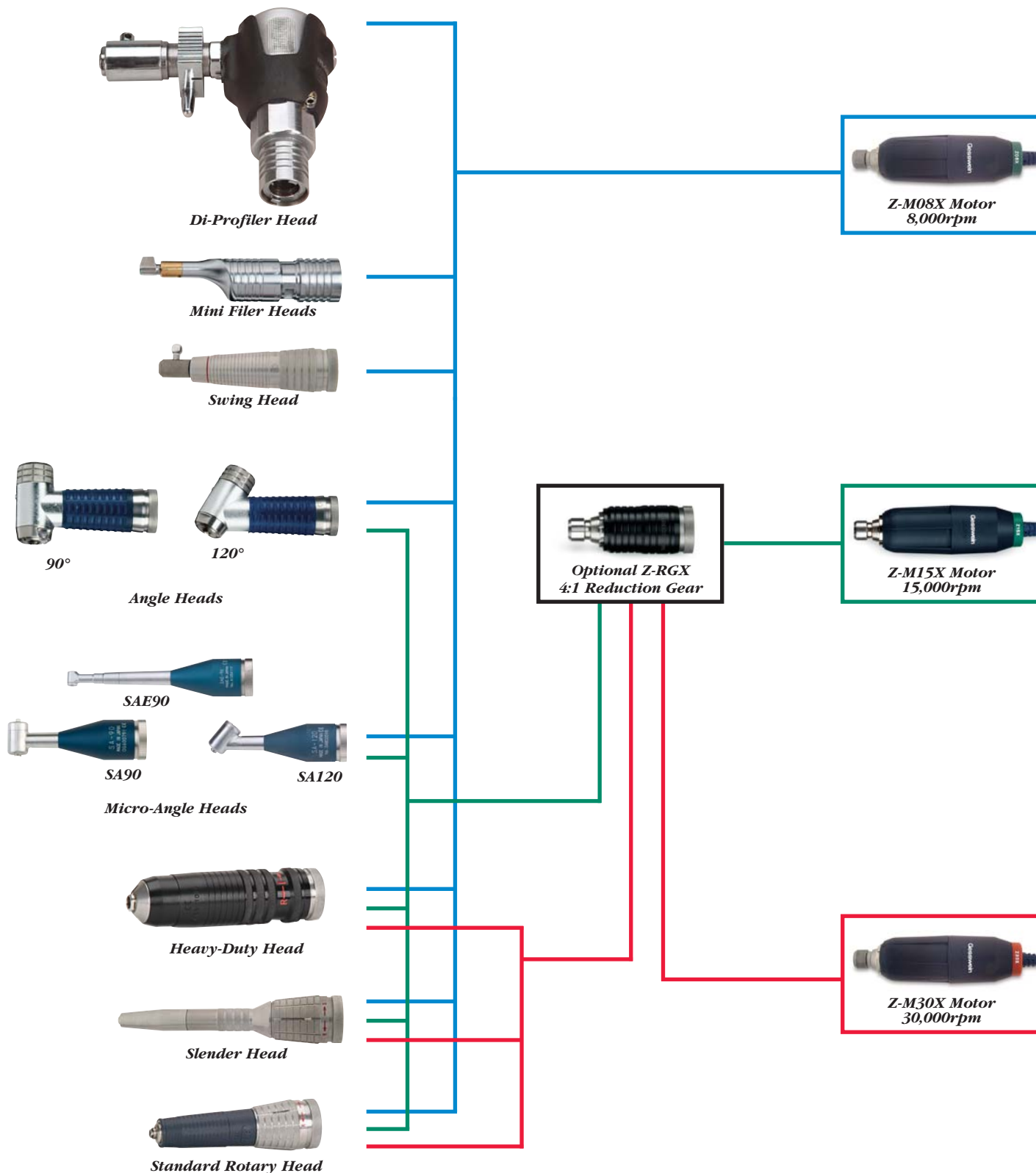

# Power Tools

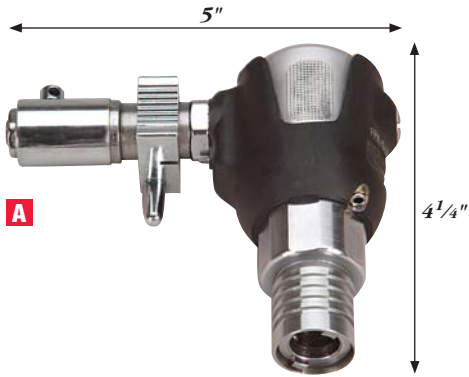

## A Di-Profiler Head – For profile polishing.

The Di-Profiler Head is our FPS Heavy-Duty Di-Profiler made to connect and run from a Power Hand 2X motor. Features heavy-duty connecting rod and front end designed to accept shanks up to 1/4" (6.4mm). Comes complete with storage case, wrench and lubricating oil. For best results and most efficient polishing, operate this head between 5,000 and 8,000rpm with a stroke of 1–3.0mm.

Description	Item#	Each
Di-Profiler Head	<b>510-2267</b>	<b>\$1,230.00</b>

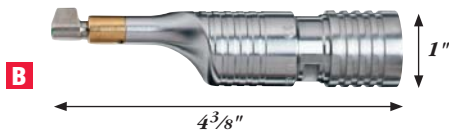

## B Z-MFX Mini Filer Heads

Mini filer heads for lightweight profiling. Slim nose design allows polishing and finishing of narrow, confined spaces. Choose from two stroke lengths. Both models hold tools up to 3.5mm diameter (such as Diamond Tips on p. 197). For best results, use with Z-M08X motor.

Fixed Stroke Length	Max. Strokes /Min.	Item#	Each
0.5mm	12,000	<b>510-2266</b>	<b>\$595.00</b>
1.8mm	12,000	<b>510-2265</b>	<b>595.00</b>

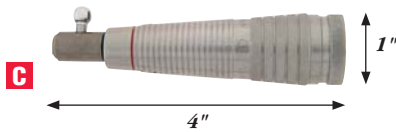

## C Swing Head – For polishing base areas in deep cavities and slots.

This head is identical to that on our SZX Profiler. It gives a unique side-to-side reciprocating action with a stroke that is easily adjustable. It's perfect for polishing base areas in deep cavities, corners and deep slots and helps eliminate rounding of sharp corners. Prevents bottoming out in blind holes. Holds 1.5 to 5mm (3/16") diameter tools. Use on Z-M08X motor assembly only.

Description	Item#	Each
C. Swing Head	<b>510-2256</b>	<b>\$450.00</b>
Replacement Bearing	Item#	Each
Bearing #406	510-3079	\$13.20

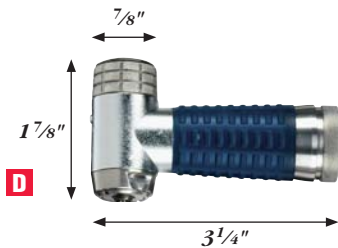

## D, E Angle Heads

These heads are identical to those on our RZ-15X and CZ-15X rotary handpieces. They employ double spur gears that provide greater power than our Micro-Angle Heads. Use on Z-M15X or Z-M08X motor assemblies only. Supplied with 3mm and 1/8" collets; 3/32" collet also available (see p. 99).

Description	Item#	Each
D. Z-ANX Right-Angle Head (90°)	<b>510-2240</b>	<b>\$395.00</b>
E. Z-CNX Contra-Angle Head (120°)	<b>510-2250</b>	<b>395.00</b>
Replacement Bearing	Item#	Each
Bearing #215	510-3077	\$13.20

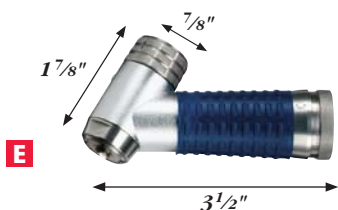

## Safety Recommendations – For Di-Profiler, Z-MFX Mini Filer and Swing Heads.

Prolonged use of vibrating or reciprocating tools may result in vibration-induced circulation problems in the hands. Always follow safe operating procedures. Using hand protection (i.e., insulated gloves) and taking frequent breaks can help minimize but not guarantee against injury. Operating these types of tools in cold weather or with a tight grip will reduce the period of operation before risking potential injury. Individuals with a tendency to suffer from poor circulation, frequently cold fingers or itchy hands should closely monitor the condition of their hands. If symptoms appear, seek medical advice immediately.

**A, B, C Micro-Angle Heads**

**For chamfering and deburring deep holes.**

Use these to reach into tight, inaccessible areas. Available in right-angle, contra-angle and 90° mini versions to reach into deep holes. Use on Z-M15X or Z-M08X motor assemblies only (see p. 98). Each supplied with collet as indicated in chart below. SAE90 Mini Micro accepts only 1/16" shanked tools; SA90 and SA120 can be fitted with optional 3/32" and 1/8" collets (see p. 99). Max. operating speed: 15,000rpm.

Description	Item#	Each
<b>A.</b> SA90 90° Right-Angle, 3mm Collet	<b>510-2255</b>	<b>\$429.00</b>
<b>B.</b> SA120 120° Contra-Angle, 3mm Collet	<b>510-2260</b>	<b>360.00</b>
Optional 3/32" Collet	<b>510-0183</b>	<b>73.45</b>
Optional 1/8" Collet	<b>510-0185</b>	<b>73.45</b>
Replacement 3mm Collet	510-0184	73.45
<b>C.</b> SAE90 90° Mini Micro, 1/16" Collet	<b>510-2261</b>	<b>360.00</b>
Replacement Bearings	Item#	Each
SA 90 Bearing #104	510-3086	\$13.20
SA 90 Bearing #113	510-3084	18.00
SA 90 Bearing #115	510-3083	18.00
SA 120 Bearing #104	510-3086	13.20
SA 120 Bearing #113	510-3084	18.00
SA 120 Bearing #115	510-3083	18.00
SAE 90 Bearing #113	510-3084	18.00
SAE 90 Bearing #116	510-3083	18.00

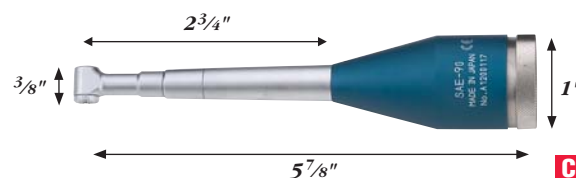
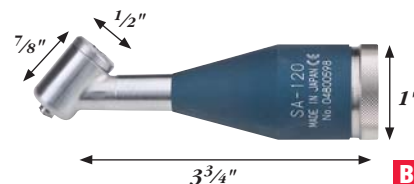
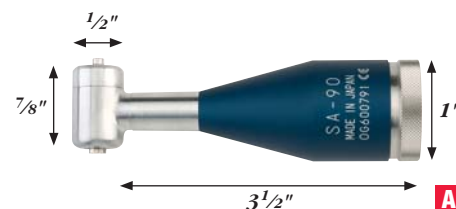

**D Z-HDX Heavy-Duty Head – For use with 1/4" shanked tools.**

Use with large tools through 1/4" shank for greater stock removal. Compatible with all motor assemblies. Supplied with a 1/4" collet; 3/32", 1/8" and 6.0mm collets also available (see p. 99).

Description	Item#	Each
<b>D.</b> Z-HDX	<b>510-2230</b>	<b>\$365.00</b>
Replacement Bearing	Item#	Each
Bearing #209	510-3088	\$13.20



**E Z-SLX Slender Head – For access into deep ribs and holes.**

Pencil-like design only 3/8" (9.0mm) in diameter at the finger grips gives 1 9/16" (40mm) more reach than a standard rotary head. Ideal for intricate, deep, hard-to-reach cavities and delicate areas. Compatible with all motor assemblies. Supplied with a 1/8" collet; 3/32" and 3mm collets also available (see p. 99).

Description	Item#	Each
<b>E.</b> Z-SLX	<b>510-2220</b>	<b>\$379.00</b>
Replacement Bearings	Item#	Each
Bearing #105	510-3086	\$13.20
Bearing #211	510-3082	13.20



**F Z-STX Standard Rotary Head**

This all-purpose rotary head comes standard with the Z-08X, Z-15X and Z-30X rotary handpieces. Compatible with all motor assemblies. Supplied with a 3/32" collet; 1/8" and 3mm collets also available (see p. 99).

Description	Item#	Each
<b>F.</b> Z-STX	<b>510-2200</b>	<b>\$255.00</b>
Replacement Bearings	Item#	Each
Bearing #206	510-3074	\$13.20
Bearing #208	510-3072	13.20





**A**

## **A Z-M08X Motor**

This 8,000rpm motor has a high torque rating. Can be used with all head attachments. Not for use with 4:1 Reduction Gear.

Description	Max. RPM	Item#	Each
<b>A.</b> Z-M08X motor	8,000	<b>510-2258</b>	<b>\$315.00</b>
Replacement Bearings		Item#	Each
Bearing #201		510-3087	\$13.20
Bearing #205		510-3073	13.20



**B**

## **B Z-M15X Motor**

This 15,000rpm motor is our strongest. Can be used with all head attachments except Swing Head, Di-Profiler Head and Mini Filer Heads.

Description	Max. RPM	Item#	Each
<b>B.</b> Z-M15X motor	15,000	<b>510-2275</b>	<b>\$250.00</b>
Replacement Bearings		Item#	Each
Bearing #201		510-3087	\$13.20
Bearing #205		510-3073	13.20



**C**

## **C Z-M30X Motor**

This 30,000rpm motor has good speed for general-purpose applications. For use with the Heavy-Duty Head, Slender Head and Standard Rotary Head only.

Description	Max. RPM	Item#	Each
<b>C.</b> Z-M30X motor	30,000	<b>510-2285</b>	<b>\$320.00</b>
Replacement Bearings		Item#	Each
Bearing #201		510-3087	\$13.20
Bearing #205		510-3073	13.20

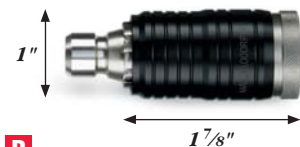

**D**

## **D Z-RGX Reduction Gear (4:1)**

Connect between rotary motor and head assembly for four times the torque. Reduces speed to one-fourth of original. Ideal for angle heads, work requiring high torque at low speed or diamond polishing with felt discs. Use with Z-M15X and Z-M30X motor assemblies. Should not be used with Swing Head, Di-Profiler Head or Mini-Filer Heads.

Description	Item#	Each
<b>D.</b> Z-RGX	<b>510-2205</b>	<b>\$255.00</b>
Replacement Bearings	Item#	Each
Bearing #202	510-3074	\$13.20
Bearing #205	510-3074	13.20
Bearing #252	510-3072	13.20
Bearing #255	510-3072	13.20



**E**

**F**

**G**

## **E, F, G Carbon Brushes for all Rotary Motors**

For Handpiece Motors	Item#	Set of 2
<b>E.</b> Z-08X, Z-M08X, Z-15X, Z-M15X, Z-30X, Z-M30X, RZ-15X, CZ-15X, SZX	<b>510-0163</b>	<b>\$18.75</b>
<b>F.</b> Z-20XS, Z-35XS	<b>510-0169</b>	<b>19.50</b>
<b>G.</b> Z-55X	<b>510-0168</b>	<b>19.50</b>



**A - C Collets for Straight and Angle Rotary Handpieces**

For all Power Hand 2X Straight and Angle Handpieces except Z-HDX Heavy-Duty Head and Micro-Angle Heads.

Size	Item#	Each
<b>A.</b> 3/32" (2.35mm)	<b>501-0100</b>	<b>\$35.00</b>
<b>B.</b> 3.0mm	<b>501-0106</b>	<b>35.00</b>
<b>C.</b> 1/8" (3.2mm)	<b>501-0105</b>	<b>35.00</b>



**D Collet for SAE90 Micro-Angle Head**

For Power Hand 2X SAE90 Micro-Angle Head only.

Size	Item#	Each
1/16" (1.6mm)	<b>510-0186</b>	<b>\$51.45</b>



**E, F Collets for Z-HDX Heavy-Duty Head**

For Power Hand 2X Z-HDX Heavy-Duty Head only.

Size	Item#	Each
3/32" (2.35mm)	<b>501-0103</b>	<b>\$61.25</b>
1/8" (3.2mm)	<b>501-0104</b>	<b>61.25</b>
<b>E.</b> 6.0mm	<b>501-0107</b>	<b>61.25</b>
<b>F.</b> 1/4" (6.35mm)	<b>501-0108</b>	<b>61.25</b>



**G - I Reducing Collets**

Use the proper reducing collet to convert your standard 1/8" or 3/32" collet to hold a 3/32" or 1/16" tool shank. Simply slip reducing collet into collet on your Power Hand 2X standard or angle head to use smaller shanked tools. Make sure both the reducing collet and the tool shank are fully inserted into the collet. Stainless steel. For 3mm collets see pp. 158 and 170.

Size	Item#	Each
<b>G.</b> 1/8" to 3/32"	<b>816-1501</b>	<b>\$12.90</b>
<b>H.</b> 1/8" to 1/16"	<b>816-1502</b>	<b>12.90</b>
<b>I.</b> 3/32" to 1/16"	<b>816-1503</b>	<b>12.90</b>



**J - O POWER/HAND® 2X Replacement Parts**

**J Chuck Joint Wrench**

Description	Item#	Each
For all Straight and Angle Heads	<b>510-0179</b>	<b>\$3.35</b>

**K, L Collet Wrench**

Description	Item#	Each
<b>K.</b> For all Straight and Angle Heads	<b>510-0180</b>	<b>\$8.40</b>
<b>L.</b> For Z-HDX Heavy-Duty Head	<b>510-0182</b>	<b>8.70</b>

**M Collet Changing Tools for Micro-Angle Heads**

Description	Item#	Each
<b>M.</b> For SA90 and SA120 Heads	<b>510-0187</b>	<b>\$51.45</b>
For SAE90 Head	<b>510-0188</b>	<b>43.95</b>

**N First-Generation Power Cord**

Description	Item#	Each
For two-piece Straight Rotary Handpieces, Angle Handpieces and SZX Profiler	<b>510-0171</b>	<b>\$39.00</b>

**O Second-Generation Power Cord**

Description	Item#	Each
For one-piece Straight Rotary Handpieces	<b>510-0170</b>	<b>\$39.00</b>



## Gesswein/Foredom® Flexible Shaft Motors and Kits

Used for a variety of operations, including deburring of diecast or machined parts, weld finishing, rust and scale removal, polishing of molds and dies and drilling of metal and plastic. Our wide selection of flexible shaft motors, handpieces and accessories makes it possible to grind and finish almost any material. All have fully grounded wiring. Made in USA. Each motor comes complete with flexible shaft and sheath. Motors are sold individually, with handpiece, with handpiece and foot pedal or in Kits that include motor, handpiece, foot rheostat, accessory set and rotating bur holder. Backed by a two-year manufacturer's warranty.

### Motor Specifications:

	TX, TXM, TXH and TXMH	SR, SRM and SRH	LX and LXB
Max. Operating Speed	15,000rpm	18,000rpm	5,000rpm
Power	1/3 HP	1/6 HP	1/25 HP
Applications	Toughest grinding and finishing	General-purpose grinding and finishing	Controlled grinding and finishing



**A**



**B**



**C**



**D**

### A - D Foredom® Series TX – 1/3 HP

These extra-powerful 1/3 HP, permanent-magnet DC motors deliver exceptional torque at all speeds. Capable of this torque due to the fact that they are made of rare earth magnets in place of universal wound magnets. Offer great tool control under any load. Meant for toughest grinding, deburring and polishing applications. Speed range: 0–15,000rpm. 50/60Hz. Not available in 230V.

- TX is a hanging-style flexible shaft motor with 39" shaft and sheath. Use with TXR or SXR foot rheostat or EMX speed controller (see p. 102) and all standard quick change handpieces (see pp. 104–105).
- TXM is a bench-mounted flexible shaft motor with 39" shaft and sheath and built-in speed control. Use with all standard quick change handpieces (see pp. 104–105).
- TXH is a hanging-style square-drive flexible shaft motor with heavy-duty 60" flexible shaft with sheath liner/silencer. Ideal for the toughest applications using large stones and tools mounted on 1/4" and 6mm shanks. Use with TXR or SXR foot rheostat or EMX speed controller (see p. 102) and 25H, 30H and 44HT handpieces (see p. 103).
- TXMH is a bench-mounted square-drive flexible shaft motor with heavy-duty 60" flexible shaft with sheath liner/silencer and built-in speed control. Ideal for the toughest applications using large stones and tools mounted on 1/4" and 6mm shanks. Use with 25H, 30H and 44HT handpieces (see p. 103).

Description	Electrical	Item#	Each
<b>A.</b> TX Motor	115V	<b>850-0381</b>	<b>\$194.50</b>
TX + 30 + TXR-1	115V	<b>850-0384</b>	<b>299.75</b>
TX + 30 + SXR-1	115V	<b>850-1469</b>	<b>355.25</b>
<b>B.</b> TXM Motor	115V	<b>850-0379</b>	<b>288.00</b>
TXM + 30	115V	<b>850-0385</b>	<b>367.25</b>
<b>C.</b> TXH Motor	115V	<b>850-0465</b>	<b>234.00</b>
TXH + 30H + TXR-1	115V	<b>850-0467</b>	<b>346.00</b>
TXH + 30H + SXR-1	115V	<b>850-1467</b>	<b>383.25</b>
TXH + 44HT + SXR-1	115V	<b>850-1474</b>	<b>375.00</b>
<b>D.</b> TXMH Motor	115V	<b>850-0380</b>	<b>309.95</b>
TXMH + 30H	115V	<b>850-0388</b>	<b>395.00</b>

### Series TX Flex Shaft Accessories and Replacement Parts

Maintenance kit below includes shaft, pair of motor brushes, grease and instructions for 115V models.

Description	Item#	Each
39" Shaft for TX, SR (1/6 & 1/8 HP), S, CC, L, LB, PG, R, K	<b>850-3395</b>	<b>\$8.95</b>
39" Sheath for all models except L, PG, EE, F	<b>850-3010</b>	<b>12.95</b>
60" Shaft/Sheath, for TXH	<b>850-3408</b>	<b>58.00</b>
Maintenance Kit for TX, TXM, TXB	<b>850-4006</b>	<b>24.00</b>
Flex Shaft Grease, 1 oz. tube	<b>850-4100</b>	<b>3.50</b>

**A - C Gesswein/Foredom® Series SR – 1/6 HP**

These motors combine all the best features: power, reliability and reversibility. Built with a larger commutator, brushes and fan to increase performance and longevity, they provide all you need for general-purpose grinding and finishing. Reverse capability allows both left- and right-handers to control direction of debris. Speed range: 0–18,000rpm. 50/60Hz.

- SR is a hanging-style flexible shaft motor with 39" shaft and sheath. Use with FCT, SCT or WF-7 foot rheostat or EM speed controller (see p. 102) and all standard quick change handpieces (see pp. 104–105).
- SRM is a bench-mounted flexible shaft motor with 39" shaft and sheath and built-in speed control. Use with all standard quick change handpieces (see pp. 104–105).
- SRH is a hanging-style square-drive flexible shaft motor with heavy-duty 60" flexible shaft with sheath liner/silencer. Ideal for tough applications using large stones and tools mounted on 1/4" and 6mm shanks. Use with FCT, SCT or WF-7 foot rheostat or EM speed controller (see p. 102) and 25H, 30H or 44HT handpieces (see p. 103).

Description	Electrical	Item#	Each
<b>A.</b> SR Motor	115V	<b>850-0480</b>	<b>\$157.50</b>
SR + 30 + SCT-1	115V	<b>850-0490</b>	<b>240.75</b>
SR + 30 + FCT-1 Kit*	115V	<b>850-0495</b>	<b>180.00</b>
SR-2 Motor	230V	<b>850-0482</b>	<b>199.00</b>
SR-2 + 30 + FCH-2	230V	<b>850-0487</b>	<b>266.50</b>
SR-2 + 30 + SCH-2	230V	<b>850-0492</b>	<b>285.95</b>
<b>B.</b> SRM Motor	115V	<b>850-0497</b>	<b>226.00</b>
<b>C.</b> SRH Motor	115V	<b>850-1462</b>	<b>210.00</b>
SRH + 30H + FCT-1	115V	<b>850-1464</b>	<b>303.85</b>
SRH + 30H + SCT-1	115V	<b>850-1463</b>	<b>322.50</b>
SRH-2 Motor	230V	<b>850-1466</b>	<b>210.00</b>
SRH-2 + 30H + FCH-2	230V	<b>850-1465</b>	<b>303.85</b>
SRH-2 + 30H + SCH-2	230V	<b>850-1468</b>	<b>327.00</b>

\*Includes 54-piece flex shaft accessory set and rotating bur holder.

**D - E Foredom® Series LX, LXB – 1/10 HP**

These motors are great for low-speed, high-torque applications that require more control. Prevent tools from slowing under load. Speed range: 0–5,000rpm. 50/60Hz.

- L is a hanging-style flexible shaft motor with 39" shaft and more flexible neoprene sheath. Use with TXR, SXR or WF-7 foot rheostat or EMX speed controller (see p. 102) and all standard quick change handpieces (see pp. 104–105).
- LXB is a bench-mounted flexible shaft motor with 39" shaft and more flexible neoprene sheath. Use with TXR, SXR or WF-7 foot rheostat or EMX speed controller (see p. 102) and all standard quick change handpieces (see pp. 104–105).

Description	Electrical	Item#	Each
<b>D.</b> LX Motor	115V	<b>850-1220</b>	<b>\$185.00</b>
LX-2 Motor	230V	<b>850-1221</b>	<b>185.00</b>
<b>E.</b> LXB Motor	115V	<b>850-1240</b>	<b>241.00</b>
LXB-2 Motor	230V	<b>850-1241</b>	<b>241.00</b>

**Series SR and L Flex Shaft Accessories and Replacement Parts**

Maintenance kits below include shaft, pair of motor brushes, grease and instructions for 115V and 230V models, unless otherwise noted.

Description	Item#	Each
39" Shaft for TX, SR (1/6 & 1/8 HP), S, CC, L, LB, PG, R, K, LX, LXB	<b>850-3395</b>	<b>\$8.95</b>
39" Neoprene Sheath for L, LB, LX, LXB	<b>850-3015</b>	<b>14.00</b>
39" Sheath for all models except L, PG, EE, F	<b>850-3010</b>	<b>12.95</b>
42" Shaft/Sheath, silencer and brushes for H	<b>850-3400</b>	<b>56.00</b>
60" Shaft/Sheath, silencer for SRH	<b>850-3408</b>	<b>58.00</b>
Maintenance Kit for 1/8 Series: SR, SRM, SRB, S, SM, SB	<b>850-4017</b>	<b>15.50</b>
Maintenance Kit for SR, SRM, SRB (1/6 HP)	<b>850-4020</b>	<b>16.00</b>
Maintenance Kit for CC (115V only)	<b>850-4015</b>	<b>16.00</b>
Flex Shaft Grease, 1 oz. tube	<b>850-4100</b>	<b>3.50</b>



**A**



**B**



**C**



**D**



**E**



**A**

**A Foredom® TXR Rheostat**

Solid-state foot-operated speed controller for exceptionally smooth control over the entire speed range. Features heavy-duty, low-profile Rynite plastic housing with wide footpad and skid-resistant bottom for comfort and stability. Runs continuously without heat buildup. Measures 6¾"L x 4½"W x 2½"H. 50/60Hz. CSA listed. Ship. wt: 1.25 lbs.

Model	Electrical	For Flex Shaft	Item#	Each
TXR-1	115V	TX, TXB, TXH, TXBH, LX, LXB	<b>850-3510</b>	<b>\$44.50</b>



**B**

**B Foredom® SXR, SCH and SCT Foot Rheostats**

Solid-state foot-operated speed controllers for immediate response with light pressure. Feature heavy-duty, low-profile cast-iron housing with ribbed top and skid-resistant bottom for comfort and stability. Run continuously without heat buildup. Measure 6¼"L x 5"W x 2¼"H. 50/60Hz. Ship. wt: 5.25 lbs.

Model	Electrical	For Flex Shaft	Item#	Each
<b>B. SXR-1</b>	115V	TX, TXB, TXH, TXBH, LX, LXB	<b>850-3508</b>	<b>\$60.00</b>
SCH-1	115V	H, HB	<b>850-3455*</b>	<b>49.00</b>
SCH-2	230V	1/6 HP SR, H, HB, 1/6 SRB	<b>850-3456</b>	<b>53.00</b>
SCT-1	115V	1/6 HP SR, 1/6 HP SRB, 1/6 HP SRH, 1/8 HP SR, 1/8 HP SRB, S, SB, CC, L, LB	<b>850-3503*</b>	<b>49.00</b>
SCT-2	230V	1/8 HP SR, 1/8 HP SRB, S, SB, CC, L, LB	<b>850-3504</b>	<b>60.00</b>

*\*CSA Listed*



**C**

**C Foredom® FCH and FCT Foot Rheostats**

Solid-state foot-operated speed controllers for exceptionally smooth control over the entire speed range. Feature heavy-duty, low-profile Rynite plastic housing with wide footpad and skid-resistant bottom for comfort and stability. Run continuously without heat buildup. Measure 6¾"L x 4½"W x 2½"H. 50/60Hz. Ship. wt: 1.25 lbs.

Model	Electrical	For Flex Shaft	Item#	Each
<b>C. FCH-1</b>	115V	H, HB	<b>850-3460*</b>	<b>\$34.45</b>
FCH-2	230V	1/6 HP SR, H, HB, 1/6 HP SRB, 1/6 HP SRH	<b>850-3461</b>	<b>35.00</b>
FCT-1	115V	1/6 HP SR, 1/6 HP SRB, 1/6 HP SRH, 1/8 HP SR, 1/8 HP SRB, S, SB, CC, L, LB	<b>850-3480*</b>	<b>30.00</b>
FCT-2	230V	1/8 HP SR, 1/8 HP SRB, S, SB, CC, L, LB	<b>850-3485</b>	<b>34.45</b>

*\*CSA Listed*



**D**

**D WF-7 Foot Rheostat**

Ultra-tough solid-state foot-operated speed controller with convenient extra-wide treadle. Features rugged, low-profile cast-iron housing with ribbed top and skid-resistant bottom for comfort and stability. Runs continuously without heat buildup. Measures 5¼"L x 7"W x 1¾"H. 50/60Hz. CSA listed. Ship. wt: 4.25 lbs.

Model	Electrical	For Flex Shaft	Item#	Each
WF-7	115V	1/6 HP SR, 1/6 HP SRB, 1/6 HP SRH, 1/8 HP SR, 1/8 HP SRB, S, SB, CC, L, LB	<b>850-3505</b>	<b>\$126.00</b>



**E**

**E Foredom® Manual Speed Controllers**

Dial-operated speed controllers for benchtop use—great alternatives to foot rheostats. Feature tough plastic housing with low profile for stability. Measure 6"L x 5"W x 2½"H. Also available in 230V. 50/60Hz. Ship. wt: 2.25 lbs.

Model	Electrical	For Flex Shaft	Item#	Each
<b>E. EMX-1</b>	115V	TX, TXB, TXH, TXBH, LX, LXB	<b>850-3516</b>	<b>\$67.00</b>
EMH-1	115V	H, HB	<b>850-3515</b>	<b>59.00</b>
EM-1	115V	1/6 HP SR, 1/6 HP SRB, 1/6 HP SRH, 1/8 HP SR, 1/8 HP SRB, S, SB, CC, L, LB	<b>850-3511</b>	<b>53.00</b>



**Heavy-Duty Rotary Handpieces for Models TXH, TXMH and H only**

All three handpieces have square drives and quickly attach with positive sheath locking mechanisms to TXH, TXMH (see pp. 100–101) and H flexible shafts. They all have shielded bearings, which require no lubrication. Compact size makes them easy to use in tight areas. Light weight prevents hand fatigue.

**A Freedom® #25H**

Features one-piece spindle construction with large, permanently lubricated, shielded ball bearings for cool running during continuous use. Complete with 1/4" collet, pin and wrench. Measures 1" dia. x 6 1/8"L. Weighs 8.5 oz.

Description	Item#	Each
<b>A. #25H</b>	<b>850-1340</b>	<b>\$149.00</b>
Collets	Item#	Each
1/16" *	<b>850-5200</b>	<b>\$17.50</b>
3/32" *	<b>850-5210</b>	<b>17.50</b>
1/8" *	<b>850-5220</b>	<b>17.50</b>
1/4" *	<b>850-5240</b>	<b>17.50</b>
3/16" *	<b>850-5230</b>	<b>17.50</b>
3mm	<b>850-5242</b>	<b>17.50</b>
Set of five asterisked collets	<b>850-5052</b>	<b>79.00</b>



**A**

**B Freedom® #30H**

Three-jaw Jacobs chuck handpiece with prelubricated, shielded ball bearings. Accommodates shank sizes up to 5/32". Complete with chuck key. Measures 1" dia. x 5 5/8"L. Weighs 7.25 oz.

Description	Item#	Each
<b>B. #30H</b>	<b>850-1355</b>	<b>\$65.50</b>
Foam Comfort Grip	<b>850-0003</b>	<b>1.95</b>
Replacement Chuck Key	850-3550	2.50



**B**

**C Freedom® #44HT**

Similar to #30H handpiece but complete with 1/4" collet instead of chuck. Measures 1" dia. x 6 1/8"L. Weighs 8.5 oz.

Description	Item#	Each
<b>C. #44HT</b>	<b>850-1455</b>	<b>\$50.95</b>
Collets	Item#	Each
1/16" *	<b>850-5410</b>	<b>\$7.00</b>
3/32" *	<b>850-5420</b>	<b>7.00</b>
1/8" *	<b>850-5430</b>	<b>7.00</b>
5/32" *	<b>850-5440</b>	<b>7.00</b>
3/16"	<b>850-5450</b>	<b>7.00</b>
1/4" *	<b>850-5470</b>	<b>7.00</b>
3mm*	<b>850-5475</b>	<b>7.00</b>
6mm*	<b>850-5480</b>	<b>7.00</b>
Set of seven asterisked collets	<b>850-5400</b>	<b>45.00</b>



**C**

**D Accessory Set for Rotary Handpieces**

Set contains 90 of our most popular wheels, brushes, mandrels and buffs, all with 3/32" shanks for your rotary handpiece—everything you need for grinding, sanding and buffing. Includes texturing wheels, cut-off discs and a selection of felt bobs and brushes. Conveniently packaged in a 24-compartment plastic storage case.

Description	Item#	Each
Accessory Set for Rotary Handpieces	<b>850-0510</b>	<b>\$49.95</b>



**D**

**Rotary Handpieces for Flexible Shaft Machines**

We offer a wide selection of handpieces to fit your needs, including both rotary and reciprocating handpieces in straight and angled styles with fixed collets, changeable collets or chucks. Several models come with a quick-tool-change mechanism, and many are available with a duplex spring for better control. All quickly detach from shaft. For use with all flexible shaft motors except models TXH, TXMH and H.



**A Foredom® #30**

Our most popular handpiece for all-purpose use. Geared three-jaw Jacobs chuck accepts shank sizes from 0" to 5/32". Pre-lubricated ball bearings require no maintenance. Measures 1" dia. x 5"L. Weighs 6 oz. Complete with chuck key.

Description	Item#	Each
<b>A. #30</b>	<b>850-1350</b>	<b>\$46.95</b>
Foam Comfort Grip	<b>850-0003</b>	<b>1.95</b>
Replacement Chuck Key	850-3550	2.50
Replacement Chuck with Chuck Key	850-2220	40.00

**B Foredom® #44T**

Similar to #30 handpiece but with collet instead of chuck. Holds tools through 1/4". Eight collets available. Comes complete with 1/4" collet, pin and wrench for changing collets. Pre-lubricated ball bearings require no maintenance. Measures 1" dia. x 5 1/2"L. Weighs 7 oz.

Description	Item#	Each
<b>B. #44T</b>	<b>850-1425</b>	<b>\$47.00</b>
Collets	Item#	Each
1/16" *	<b>850-5410</b>	<b>\$7.00</b>
3/32" *	<b>850-5420</b>	<b>7.00</b>
1/8" *	<b>850-5430</b>	<b>7.00</b>
5/32" *	<b>850-5440</b>	<b>7.00</b>
3/16"	<b>850-5450</b>	<b>7.00</b>
1/4" *	<b>850-5470</b>	<b>7.00</b>
3mm*	<b>850-5475</b>	<b>7.00</b>
6mm*	<b>850-5480</b>	<b>7.00</b>
Set of seven asterisked collets	<b>850-5400</b>	<b>45.00</b>

**C Foredom® #35**

Unique elliptical drive system boosts handpiece rpm to 35,000 regardless of flex shaft motor speed rating. Ideal for use with carbide and diamond tool accessories. Has pre-lubricated double-shielded ball bearings. Six collets available. Supplied with 1/8" or 3mm collet. Measures 1 1/8" dia. x 5"L. Weighs 8 oz.

Description	Item#	Each
<b>C. #35 w/1/8" collet</b>	<b>850-1400</b>	<b>\$139.50</b>
#35 w/3mm collet	<b>850-1410</b>	<b>139.50</b>
Collets	Item#	Each
1/16" *	<b>850-5200</b>	<b>\$17.50</b>
3/32" *	<b>850-5210</b>	<b>17.50</b>
1/8" *	<b>850-5220</b>	<b>17.50</b>
1/4" *	<b>850-5240</b>	<b>17.50</b>
3/16" *	<b>850-5230</b>	<b>17.50</b>
3mm	<b>850-5242</b>	<b>17.50</b>
Set of five asterisked collets	<b>850-5052</b>	<b>79.00</b>

**D, E Foredom® #18 and #18D Quik Change™**

Each has a unique push-release collet that improves productivity. Ideal for any application requiring many tool changes. Permanently lubricated ball bearing allows cool, quiet, continuous operation. For 3/32" shank tools only. Supplied with 3/32" collet. Measures 7/8" dia. x 7"L (without duplex). Weighs 3.5 oz.

Description	Item#	Each
<b>D. #18 without duplex spring</b>	<b>850-1325</b>	<b>\$99.75</b>
<b>E. #18D with duplex spring</b>	<b>850-1320</b>	<b>112.00</b>
Replacement Collet, 3/32"	850-5485	26.50

**A, B #8 and #8D**

Each has prelubricated ball bearings for sustained operation at high speeds without overheating. Fingertip operation of collet chuck and sliding protective sleeve allows quick tool changing. Ideal for close work. Supplied with  $\frac{3}{32}$ " collet. Measures  $\frac{3}{4}$ " dia. x 6"L (without duplex). Weighs 4 oz.

Description	Item#	Each
<b>A.</b> #8 without duplex spring	<b>850-1250</b>	<b>\$50.00</b>
<b>B.</b> #8D with duplex spring	<b>850-1300</b>	<b>60.00</b>
Collets	Item#	Each
$\frac{1}{32}$ " *	<b>850-5020</b>	<b>\$7.00</b>
$\frac{1}{16}$ " *	<b>850-5030</b>	<b>7.00</b>
$\frac{3}{32}$ " *	<b>850-5040</b>	<b>7.00</b>
$\frac{1}{8}$ " *	<b>850-5050</b>	<b>7.00</b>
3mm	<b>850-5060</b>	<b>7.00</b>
Set of four asterisked collets	<b>850-5010</b>	<b>25.00</b>

**C, D #10 and #10D**

Each features a quick-release lever for rapid tool changing. Prelubricated ball bearings require no maintenance. For  $\frac{3}{32}$ " shank tools only. Measures  $\frac{3}{4}$ " dia. x  $10\frac{3}{4}$ "L (without duplex). Weighs 5 oz.

Description	Item#	Each
<b>C.</b> #10 without duplex spring	<b>850-1252</b>	<b>\$199.00</b>
<b>D.</b> #10D with duplex spring	<b>850-1253</b>	<b>212.00</b>

**E Foredom® #28**

A lightweight handpiece well-suited for intricate work as well as for general grinding, polishing, deburring and carving applications. Slim tapered grip provides comfort and control. Permanently lubricated ball bearings ensure smooth operation. Supplied with  $\frac{3}{32}$ " and  $\frac{1}{8}$ " collets, pin and wrench for changing collets. Measures  $\frac{3}{4}$ " dia. x  $5\frac{3}{8}$ "L.

Description	Item#	Each
<b>E.</b> #28	<b>850-1348</b>	<b>\$47.00</b>
Collets	Item#	Each
$\frac{3}{32}$ "	<b>850-5040</b>	<b>\$7.00</b>
$\frac{1}{8}$ "	<b>850-5050</b>	<b>7.00</b>
3mm	<b>850-5060</b>	<b>7.00</b>

**F, G Foredom® #52 and #52D**

Lightweight handpieces with plastic housing. Each features a remarkably simple yet effective quick-change mechanism that lets the user change tools in seconds: just push chuck out to open, remove old tool, insert new one, and pull chuck back to lock in place. Permanently lubricated ball bearings ensure smooth operation. Accepts  $\frac{3}{32}$ " shank tools.

Description	Item#	Each
<b>F.</b> #52 without duplex spring	<b>850-1460</b>	<b>\$99.00</b>
<b>G.</b> #52 with duplex spring	<b>850-1461</b>	<b>114.00</b>

**H VTX – For right-angle access.**

Right-angle handpiece with a telescopic head. Maximum extension is  $3\frac{1}{4}$ ". Excellent for hard-to-reach areas. Complete with  $\frac{3}{32}$ " and  $\frac{1}{8}$ " collets and a wrench for changing collets. Measures  $\frac{3}{4}$ " diameter,  $7\frac{3}{4}$ " long (telescopes to 11" long). Weighs 6.5 oz.

Description	Item#	Each
<b>H.</b> VTX	<b>850-2150</b>	<b>\$445.00</b>
Collets	Item#	Each
$\frac{3}{32}$ "	<b>850-5340</b>	<b>\$29.85</b>
$\frac{1}{8}$ "	<b>850-5350</b>	<b>31.60</b>
3mm	<b>850-5255</b>	<b>45.00</b>





**A Adjustable Telescoping Flex Shaft Hanger**

Now you can adjust the height of your flex shaft motor in seconds. Sturdy metal rod attaches firmly to bench with three screws. Height can then be set anywhere from 26" to 41" simply by adjusting the wing nut. Swivel arm at top increases flexibility even more. Chrome-plated finish.

Description	Item#	Each
Adjustable Telescoping Flex Shaft Hanger	<b>850-0501</b>	<b>\$21.95</b>

**B Freedom® Flex Shaft Hanger with Handpiece Rest**

Our Freedom Flex Shaft Hanger stands 21" tall and holds one motor above the work surface. Base clamp opens to 2¼" to attach the hanger to the edge of a workbench or table. Comes with handpiece rest that slips onto hanger to secure handpiece when not in use. Handpiece rest's back cutout holds motor cord away from your work.

Description	Item#	Each
Freedom Flex Shaft Hanger with Handpiece Rest	<b>850-0500</b>	<b>\$39.00</b>



**C, D Freedom® Flex Shaft Hangers**

T-top configuration holds two flex shafts on a sturdy metal rod. The T-top may be rotated 360° and locked in place and can slide from side to side with a locking screw. The pole can be adjusted up to 3' from the benchtop so flex shafts can be hung at the most convenient working height. Two models available. One has a clamp for easy attachment to any benchtop up to 2¼" thick. It includes a convenient tool tray to hold your handpiece key, collets and other tools within easy reach. The other hanger has a mounting base that can be screwed or bolted to side or top of bench. Both hangers come equipped with handpiece holders, which may be locked in the most comfortable position.

Description	Item#	Each
<b>C.</b> Double Hanger with Clamp and Tool Tray	<b>850-0502</b>	<b>\$45.95</b>
<b>D.</b> Double Hanger with Mounting Base	<b>850-0503</b>	<b>69.00</b>

**E Duplex Spring Adapter – Add flexibility to your handpiece.**

Provides flexibility to the handpiece for better control. The spring drive is made of a special steel and protected by a flexible spring cover. Works on all Gesswein/Freedom or similar flexible shaft units. Simply connect between the handpiece and the shaft. Measures 6" overall length.

Description	Item#	Each
Duplex Spring Adapter	<b>850-1962</b>	<b>\$66.80</b>



**F, G, H Replacements for Handpieces with Duplex Springs**

Description	Item#	Each
<b>F.</b> Inner Duplex Spring (spring only)	850-3800	\$8.50
<b>G.</b> Easy Duplex Spring Assembly (inner spring plus connectors)	850-2223	11.75
<b>H.</b> Outer Cover for Duplex Spring	850-3802	15.00



**I Handpiece Oil**

Recommended for all our flexible shaft handpieces. Supplied in 2 oz. tube.

Description	Item#	Each
Handpiece Oil	<b>850-4105</b>	<b>\$3.00</b>





**A Foredom® Precision Drill Press DP-95**

A heavy-duty drill press designed for use with your flexible shaft, Foredom #30, #30H, #44 and #44H handpieces or any 1" diameter handpiece. Securely holds the handpiece in a vertical position for drilling straight, accurate holes to specified depths. Equipped with a dial indicator for precise control of the vertical movement of the handpiece (in increments of 0.01mm). Ideal for precise drilling, countersinking and reaming of wood, plastic, glass and metal. Constructed of cast iron and steel.

**Specifications:**

Height	16"
Base	4"W x 5"D
Table	8"W x 3½"D
Post Diameter	¾"
Throat	2"
Stroke Length	1¼"
Ship. Wt.	12 lbs.

Description	Item#	Each
Drill Press DP-95	<b>850-0590</b>	<b>\$235.00</b>



**B Foredom® Drill Press Stand**

A rugged and precise stand that converts your flexible shaft handpiece into a drill press. Adjustable table slides up or down and can be rotated out of the way for drilling large workpieces. Will securely hold a 1" diameter handpiece (such as #30, #30H, #44 and #44H) for drilling accurate holes. Features sturdy cast-iron construction, precise and smooth action, adjustable stroke, drill depth scale and spring return. Table and handpiece holder height are adjustable for maximum flexibility.

**Specifications:**

Height	14¼"
Base	3¾" x 3½"
Table	3⅝" x 3⅝"
Post Diameter	¾"
Throat	2"
Stroke Length	1¼"
Ship. Wt.	9 lbs.

Description	Item#	Each
Drill Press Stand	<b>850-0600</b>	<b>\$142.00</b>



**C Foredom® Mini Vise**

Securely hold small parts in our Mini Vise. Has 1¾" slotted grooves in the base for mounting on a drill press or workbench. Stationary jaw has a perpendicular V-groove and movable jaw has a horizontal V-groove for holding round stock or tube. Glare-free black finish.

**Specifications:**

Jaw Width	1¼"
Jaw Opening	1½"
Overall	
Dimensions	4"L x 2⅜"W x 1½"H
Ship. Wt.	½ lb.

Description	Item#	Each
Mini Vise	<b>820-4700</b>	<b>\$19.00</b>



**D Foredom® Handpiece Holder**

This "third hand" device clamps to the workbench, allowing the operator to bring the work to the tool. Provides an economical way to convert your Foredom flexible shaft machine into a high-speed lathe. For grinding, polishing, and sanding. Adjustable height feature holds handpiece up to 10" above the workbench and rotates 360°. Clamps to benchtops up to 2¼" thick.

Description	Item#	Each
For #30, #30H, #44, #44H	<b>850-0605</b>	<b>\$35.00</b>
For #35	<b>850-0607</b>	<b>35.00</b>





**A**



**B**



**C**



**D**



**E**

**A Dremel® Variable-Speed Grinder Model #395**

Variable five-speed grinder with a range of 5,000 to 30,000rpm. Use for cutting, sharpening, cleaning, polishing and grinding applications. Double-insulated, shatter-resistant housing. Slim design fits comfortably in hand. Supplied with 1/8" collet. Measures 7 1/4"L x 1 7/16" dia. Operates on 115V AC. Weighs 1 lb., 2.5 oz.

Description	Item#	Each
Dremel Model #395	<b>850-8025</b>	<b>\$78.45</b>

**B Dremel® Single-Speed Grinder Model #275**

Same as Model #395 (above) except Model #275 operates at only one speed: 28,000rpm.

Description	Item#	Each
Dremel Model #275	<b>850-8015</b>	<b>\$48.23</b>

**Collets for Dremel® Grinders**

Size	Item#	Each
1/32"	<b>850-4155</b>	<b>\$2.10</b>
1/16"	<b>850-4150</b>	<b>2.10</b>
3/32"	<b>850-4145</b>	<b>2.10</b>
1/8"	<b>850-4140</b>	<b>2.10</b>

**C Dremel® Right-Angle Attachment**

Attaches to either #395 or #275 Dremel Grinder for increased versatility. This 90° add-on can be used for a variety of right-angle grinding, cleaning and polishing applications.

Description	Item#	Each
Dremel Right-Angle Attachment	<b>850-8020</b>	<b>\$33.35</b>

**D Dremel® Electric Engraver**

Economical, adjustable engraver for personalizing or marking valuable articles. Create unique designs on metal, wood, plastic, ceramic, glass and leather. Features handy hanger for convenient storage, calibrated stroke adjustment dial, comfortable pencil-type grip and easily replaceable carbide point. Measures 6" overall length. Cord measures 6' long. 115V, 0.2A, 60Hz. UL listed.

Description	Item#	Each
Engraver	<b>821-6010</b>	<b>\$19.75</b>
Carbide Point	<b>821-6015</b>	<b>4.87</b>
Diamond Point	<b>821-6020</b>	<b>14.87</b>

**E Dumore® Grinder Series #10-351 – 1/10 HP**

This model produces up to 22,000rpm. Primarily designed for tool and die work. Easily handles general-purpose grinding, rotary filing, deburring, cleaning and polishing jobs. Has grease-lubricated sealed ball bearings. Comes with 1/4" to 1/8" reducing collet and two wrenches. Includes 8' electrical cord. Max. grinding wheel size: 1" dia. Measures 10"L x 2 3/4" dia. at the finger grips. Weighs 3 lbs., 2 oz.

Description	Item#	Each
<b>E. Model #10-351, 115V</b>	<b>850-8520</b>	<b>\$330.00</b>
Replacement Reducing Collet, 1/4-1/8"	850-4135	9.95

**A, B Reciprocating Handpieces for Flexible Shaft Machines**

The Di-Profiler attaches to any standard Gesswein/Foredom flexible shaft machine except models TXH, TXMH and H. This precise, fast-action, easy-to-operate reciprocating tool is ideal for profile polishing, filing (see p. 214 for steel files), honing and lapping straight and curved surfaces and finishing complicated dies and molds. Each Di-Profiler allows easy stroke adjustments for fast, precise work. Spring-cushioned to prevent damage to workpiece or tool.

**A FPS Heavy-Duty Di-Profiler**

Features heavy-duty connecting rod and front end designed to accept shanks up to 1/4" (6.4mm). Comes complete with rubber sleeve, storage case, wrench and lubricating oil. For best results and most efficient polishing, operate Di-Profiler handpieces at speeds between 5,000 and 8,000rpm with a stroke of 1–3mm. Length of stroke: 0–1/4" (0–6.4mm).

Description	Item#	Each
FPS Heavy-Duty Di-Profiler	<b>850-1919</b>	<b>\$1,089.00</b>
FPS Complete Set, 110V (includes FPS Di-Profiler and Model TXM Flex Shaft with built-in dial speed control)	<b>850-1939</b>	<b>1,240.00</b>
FPS Complete Set, 220V	<b>850-1940</b>	<b>1,229.00</b>
Rubber Grip	<b>850-1937</b>	<b>53.75</b>



**B FPC Di-Profiler**

Very popular reciprocating handpiece designed to accept shanks up to 1/8" (3.5mm). Comes complete with rubber sleeve, storage case, removable tool storage trays, wrench, lathe adapter post and lubricating oil. For best results and most efficient polishing, operate Di-Profiler handpieces at speeds between 5,000 and 8,000rpm with a stroke of 1–3mm. Length of stroke: 0–1/4" (0–6.4mm).

Description	Item#	Each
FPC Di-Profiler	<b>850-1827</b>	<b>\$1,125.00</b>
FPC Complete Set, 110V (includes FPC Di-Profiler and Model TXM Flex Shaft with built-in dial speed control)	<b>850-1938</b>	<b>1,100.00</b>
Rubber Grip	<b>850-1937</b>	<b>53.75</b>



**C FMR Mini-Filers**

Each attaches to any standard Gesswein/Foredom flexible shaft machine except models TXH, TXMH and H. Designed for light-duty profiling work. Ergonomic design results in effective finishing and polishing. Slim nose is especially useful in tight spaces. Holds tools up to 3.5mm in diameter (see diamond poli files on pp. 195 and 197). Comes complete with Allen wrench and lubricating oil. Max. operating speed: 10,000 strokes per minute (5,000–7,000 strokes per minute recommended). Measures 5 3/16" L x 1 5/16" dia. Weighs 5.5 oz.

Length of Stroke	Item#	Each
1.8mm	<b>850-1922</b>	<b>\$595.00</b>
0.5mm	<b>850-1923</b>	<b>595.00</b>



**Safety Recommendations – For FPS and FPC Di-Profilers and FMR Mini Filers.**

Prolonged use of vibrating or reciprocating tools may result in vibration-induced circulation problems in the hands. Always follow safe operating procedures. Using hand protection (i.e., insulated gloves) and taking frequent breaks can help minimize but not guarantee against injury. Operating these types of tools in cold weather or with a tight grip will reduce the period of operation before risking potential injury. Individuals with a tendency to suffer from poor circulation, frequently cold fingers or itchy hands should closely monitor the condition of their hands. If symptoms appear, seek medical advice immediately.

## Air Grinders – Specially selected for mold, tool and die makers.

These air-operated rotary handpieces are perfect for precision grinding and deburring. Use reciprocating models for honing and lapping. All require Filter/Regulator-Lubricator except NSK Presto Air Turbine.

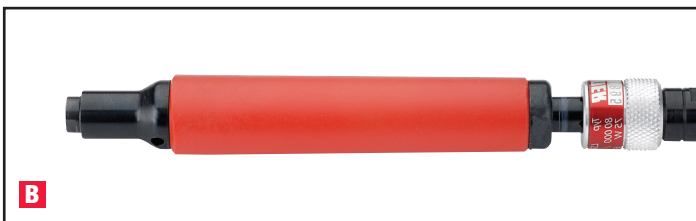
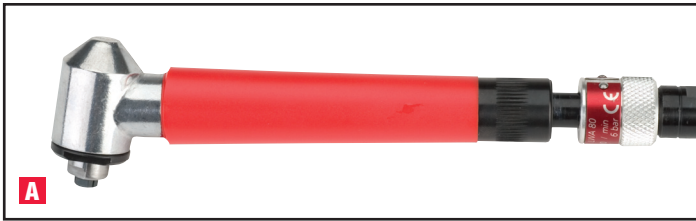

### A, B Suhner® Swiss Grinders

#### 80,000rpm, right-angle and straight rotary handpieces

These grinders achieve maximum power with minimum air consumption. Rigid rotary-vane motors provide exceptional performance and speeds up to 80,000rpm. Excellent for carbide and CBN tools. Use for milling, grinding, engraving and polishing. Light, well-balanced ergonomic design reduces operator fatigue. Scratch-resistant insulated plastic housing reduces noise level and keeps hands warmer. Additional features include precision sealed bearings, rear speed controls and rugged construction for extended heavy-duty use. Choose from slim right-angle or straight grinder with rear speed controls. Both supplied with 1/8" collet and wrench. Each requires 1/8" NPT coupler and 1/4" ID hose (see p. 115 for #850-7323). Use with Filter/Regulator-Lubricator (see p. 114). Right-angle handpiece measures 6 3/4"L x 3/4" dia. Weighs 7 oz. Straight handpiece measures 6"L x 3/4" dia. Weighs 4.2 oz.

Model	Max. RPM	PSI	CFM	Item#	Each
<b>A. Right-Angle</b>	80,000	90	6.6	<b>850-7320</b>	<b>\$529.00</b>
<b>B. Straight</b>	80,000	90	6.6	<b>850-7300</b>	<b>499.00</b>
Collets				Item#	Each
1/8" for Right-Angle				<b>850-7329</b>	<b>\$33.00</b>
1/8" for Straight				<b>850-7327</b>	<b>33.00</b>
3/32" for Right-Angle				<b>850-7331</b>	<b>33.00</b>
3/32" for Straight				<b>850-7325</b>	<b>33.00</b>

### C High-Speed Rotary Air Grinder HS80 – 80,000rpm

High-speed, quiet-running, well-balanced rotary handpiece for deburring and finishing. Ideal for precision grinding. Includes 1/8" collet (optional 3/32" and 3.0mm collets also available). Supplied with air hose, coupler and tool changing wrenches. Requires Filter/Regulator-Lubricator (see p. 114). Measures 5 7/8"L x 1 3/16" dia. Weighs 5.7 oz.

Max. RPM	PSI	CFM	Item#	Each
<b>C. 80,000</b>	90	0.30	<b>850-2235</b>	<b>\$174.00</b>
Description			Item#	Each
Optional HS80 3/32" Collet			<b>850-2236</b>	<b>\$6.50</b>
Optional HS80 3.0mm Collet			<b>850-2237</b>	<b>6.50</b>
Replacement HS80 1/8" Collet			<b>850-2238</b>	<b>6.50</b>

### D, E UHT (Ushio) Air Grinders

#### 53–65,000rpm, slim and lightweight pencil-like design

Quiet running handpieces ideal for many applications, including precision grinding, finishing and polishing. Feature self-lubricating vanes for dependable performance. Unique 1/8" fixed collet design provides extra-long ball bearing life and reduces heat buildup.

The Contra-Angle 120° model allows access to hard-to-reach, deep areas. Both offer rear speed control and rear exhaust. Supplied with 5' of 3/16" air hose, 1/4" NPT coupler, 13" exhaust hose, wrench and pin. Use with Filter/Regulator-Lubricator (see p. 114). Contra-angle handpiece measures 5"L x 7/8" dia. Weighs 5 oz. Straight handpiece measures 5 5/8"L x 5/8" dia. Weighs 4.5 oz.

Model	Max. RPM	PSI	CFM	Item#	Each
<b>D. Contra-Angle</b>	53,000	85	4.2	<b>850-0905</b>	<b>\$285.00</b>
<b>E. Straight</b>	65,000	85	4.2	<b>850-0900</b>	<b>280.00</b>



**A NSK Impulse Pencil Air Grinder – 60,000rpm**

Features a special vane design that maintains speed even under load, providing smooth and stable grinding action. Design allows sensitive control of cutting tool. Exhaust hose with silencer keeps noise to a minimum. Rotating joint prevents hose from twisting. Supplied with 1/8" collet and chuck key; 3/32" and 3mm collets available separately. Use with Filter/Regulator-Lubricator (see p. 114). Measures 6 3/4"L x 1" dia. Weighs 5.9 oz.

Max. RPM	PSI	CFM	Item#	Each
<b>A.</b> 60,000	56-85	5.83	<b>850-7230</b>	<b>\$325.00</b>
Collets			Item#	Each
3/32"			<b>850-7232</b>	<b>\$44.00</b>
3mm			<b>850-7233</b>	<b>44.00</b>



**B High-Torque Precision Air Grinder HT60 – 60,000rpm**

High-torque, quiet-running, well-balanced rotary handpiece for deburring and finishing work. Includes fixed 1/8" collet (also available with fixed 3/32" or 3.0mm collet). Supplied with air hose, coupler and tool changing wrenches. Requires Filter/Regulator-Lubricator (see p. 114). Measures 5 5/8"L x 1 1/16" dia. Weighs 6.4 oz.

Max. RPM	PSI	CFM	Item#	Each
60,000	90	0.28	<b>850-2230</b>	<b>\$134.00</b>



**C, D Nitto Kohki Air Sonic 25–35,000rpm, high-torque rotary handpieces**

Rugged Nitto Kohki Air Sonic high-torque units provide maximum power for grinding, deburring, production grinding on small castings and removing welding slag. Rear exhaust and built-in air silencers ensure quiet operation. Both supplied with 1/4" to 1/8" reducing collet sleeve, 5' of 1/4" hose with 1/2" NPT coupler, 19" exhaust hose and wrenches. Use with Filter/Regulator-Lubricator (see p. 114). L-35B measures 7"L x 1 1/4" dia. Weighs 1 lb. L-25B measures 5 3/4" L x 1 3/8" dia. Weighs 1.3 lbs.

Model	Max. RPM	PSI	CFM	Item#	Each
<b>C.</b> L-35B	35,000	85	12.3	<b>850-7012</b>	<b>\$300.00</b>
<b>D.</b> L-25B	25,000	85	14.1	<b>850-7011</b>	<b>250.00</b>
Reducing Collet Sleeves				Item#	Each
1/4" to 1/8"				<b>850-7015</b>	<b>\$15.17</b>
1/4" to 3/16"				<b>850-7016</b>	<b>15.17</b>



**E Super Hand Pneumatic Filer – 4,000 strokes/min.**

A powerful reciprocating tool for an efficient way to file. Vibration-free due to its double-piston design. Accepts tool diameters up to 1/4". Comes complete with 6' hose with 1/4" NPT connector, four coarse files (three-square, half-round, flat and round tapered) and wrench. Use with Filter/Regulator-Lubricator (see p. 114). Measures 6 1/2"L x 1 1/2" dia. Weighs 2.4 lbs.

Strokes/Minute	Stroke Length	PSI	CFM	Item#	Each
4,000	5.0mm	85.3	6	<b>850-7200</b>	<b>\$310.00</b>



**F Air Handpiece Lube Oil**

Description	Item#	Each
<b>F.</b> Air Handpiece Lube Oil, 2 oz.	<b>850-0980</b>	<b>\$12.95</b>
Air Handpiece Lube Oil, 8 oz.	<b>850-0985</b>	<b>17.50</b>





**A Angle Surface Air Grinder AG22 – 22,000rpm**

A 120°-angle rotary handpiece for grinding, chamfering, deburring and finishing welds and larger surface areas. Includes collet chuck with M7 screw shaft for mounting abrasive cup wheels and abrasive discs. Supplied with air hose, coupler, 30mm cup wheel (60 grit), ten 30mm PSA discs (60, 100 and 150 grit), 30mm PSA disc holder and changing tool for cup wheels and PSA disc holder. Requires Filter/Regulator-Lubricator (see p. 114). Measures 6<sup>3</sup>/<sub>8</sub>"L x 5<sup>5</sup>/<sub>8</sub>" dia. Weighs 7 oz.

Max. RPM	PSI	CFM	Item#	Each
A. 22,000	90	0.12	<b>850-2240</b>	<b>\$204.00</b>
Description	Dia.	Grit	Item#	Box of 48
AG22 Cup Wheel	30mm	60	<b>850-2242</b>	<b>\$42.00</b>
		100	<b>850-2243</b>	<b>42.00</b>
		150	<b>850-2244</b>	<b>42.00</b>
Description	Dia.	Grit	Item#	Box of 150
AG22 PSA Disc	30mm	60	<b>850-2229</b>	<b>\$27.50</b>
		100	<b>850-2231</b>	<b>27.50</b>
		150	<b>850-2232</b>	<b>27.50</b>
		240	<b>850-2233</b>	<b>27.50</b>
		320	<b>850-2234</b>	<b>27.50</b>
	400	<b>850-2239</b>	<b>27.50</b>	
Description	Dia.		Item#	Each
AG22 PSA Disc Holder	30mm		<b>850-2241</b>	<b>\$3.50</b>



**B Nitto Kohki Air Angle Disc Sander 22,000rpm, high-torque handpiece**

This 22,000rpm, powerful 2" right-angle sander is ideal for use on dies, molds, steel, aluminum and rubber or for finishing welds. Lightweight and compact for continuous sanding in small, confined areas. Abrasive disc capacity: 2". One-touch twist lock allows efficient abrasive disc holder replacement. Ball-bearing construction with helical steel gears provides long life. Includes side exhaust with silencer. Safety lock helps prevent accidents. Requires 1/4"-3/8" NPT air connection. Comes with goggles. See p. 73 for 1/4" PSA Disc Holders and PSA Discs. Use with Filter/Regulator-Lubricator (see p. 114). Measures 5" x 1 1/2" dia. Weighs 1.1 lbs.

Max. RPM	PSI	CFM	Item#	Each
22,000	85	14.2	<b>850-7013</b>	<b>\$320.00</b>



**C NSK Presto Air Turbine 320,000rpm, no lubrication required**

Use this lightweight, ultra-high-speed, nonlube rotary air turbine for delicate, precision applications. Features a unique dust protection mechanism that not only blows away loose powder to improve cutting efficiency but also cools the cutting tool to extend service life. For use with 1/16" tools. Purchase handpiece and hose alone, or purchase set complete with handpiece, hose, air line filter, regulator, foot control and handpiece rest. Measures 4 1/2"L x 5/8" dia. Weighs 2.5 oz.

Max. RPM	PSI	CFM	Item#	Each
320,000	35	1.4	<b>850-7236</b>	<b>\$335.00</b>
Description			Item#	Each
C. NSK Set			<b>850-7235</b>	<b>\$565.00</b>

**A Air-Operated FPD Di-Profiler Set – 10,000 strokes/min.**

Employs a high-quality, variable-speed, air-driven reciprocating handpiece similar to our popular flex shaft-driven FPC Di-Profiler (see p. 109). Use the precise, fast-action, easy-to-operate FPD Di-Profiler for profile polishing, filing, honing and lapping straight and curved surfaces and finishing complicated molds and dies. For honing, use holders shown on p. 21. In addition to FPD Di-Profiler, set includes air line, filter/regulator-lubricator, lubricating oil, 5' of reinforced flexible hose, quick-disconnect hose connector, wrench, lathe adapter post and molded storage case. FPD features high torque-to-weight ratio with low air consumption for maximum efficiency, variable speed control up to 10,000 strokes per minute, adjustable stroke from 0 to 6.0mm (0 to 1/4"), automatic lubrication and cool-running piston-type motor. Accepts tools up to 1/8" in diameter. Measures 6 3/4"L x 1 1/4" dia. Weighs 2 lbs.



Max. Strokes/ Minute	Stroke Length	PSI	CFM	Item#	Each
10,000	0–0.6mm	57	0.18–2.3	<b>850-1845</b>	<b>\$2,350.00</b>

**B Turbo Air Lapper TL70 – 35,000 strokes/min.**

Low-vibration, quiet-running, durable reciprocating handpiece with a short stroke. Excellent for general-purpose finishing and polishing of mold and die surfaces. Perfect for polishing ribs, slots and other tight areas. Produces great results with Diamond Poli Files (see pp. 147 and 149) and Super Ceramic Stones (see p. 22). Supplied with air hose, coupler, foam sleeve and three tool holders for 1mm to 1/8" flat tools and 3mm round tools. Requires Filter/Regulator-Lubricator (see p. 114). Measures 8"L x 1 1/8" dia. Weighs 6.7 oz.

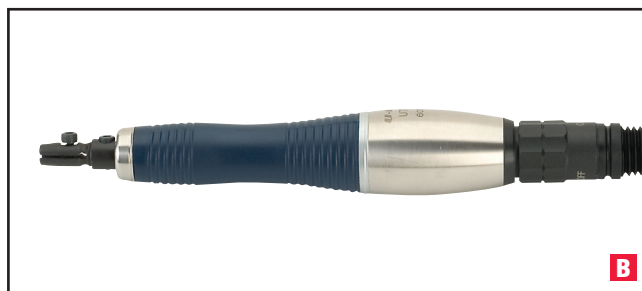

Strokes/ Minute	Stroke Length	PSI	CFM	Item#	Each
<b>B. 35,000</b>	0.7mm	90	0.19	<b>850-2245</b>	<b>\$289.00</b>
Description	Accepts Tools	Item#	Each		
Holder #64	1mm flat, 3mm round	<b>850-2246</b>	<b>\$8.50</b>		
Holder #65	1mm flat	<b>850-2247</b>	<b>8.50</b>		
Holder #62	1/8" flat	<b>850-2248</b>	<b>8.50</b>		

**C UHT (Ushio) TurboLap Air Filer – 22,000 strokes/min.**

TurboLap delivers high-speed reciprocation with high torque and a short stroke. Ideal for filing, lapping and polishing molds or honing precision parts. Makes quick work of polishing ribs, slots and intricate areas. Runs quiet and is designed to be operated for long periods without getting hot. Provides optimum results with Diamond Poli Files (see pp. 147 and 149) and Super Ceramic Stones (see p. 22). Lightweight with good balance and ergonomic soft-grip design. Supplied with hexagonal wrench, one diamond poli file, 1.5m air hose, over hose, hose bands and quick joint with filter. Accepts up to 1mm flat or 3mm round tools. Requires 1/4" NPT air connection. Use with Filter/Regulator-Lubricator (see p. 114). Measures 7"L x 1" dia. Weighs 5.9 oz.



Strokes/ Minute	Stroke Length	PSI	CFM	Item#	Each
22,000	0.7mm	90	1.65	<b>850-0930</b>	<b>\$489.00</b>

**Safety Recommendations – For FPD Di-Profiler and Vibrating Handpieces.**

Prolonged use of vibrating or reciprocating tools may result in vibration-induced circulation problems in the hands. Always follow safe operating procedures. Using hand protection (i.e., insulated gloves) and taking frequent breaks can help minimize but not guarantee against injury. Operating these types of tools in cold weather or with a tight grip will reduce the period of operation before risking potential injury. Individuals with a tendency to suffer from poor circulation, frequently cold fingers or itchy hands should closely monitor the condition of their hands. If symptoms appear, seek medical advice immediately.

## Air Tool Accessories

It is extremely important that compressed air be dried, cleaned and regulated to a pressure suitable for the operation of any air tool. All Gesswein air tools except NSK Presto Air Turbine also require lubrication to reduce friction. To prevent water vapor condensation, filters should be installed in the air line as close as possible to the air tool.



**A**

### **A** Miniature Prefilter/Coalescing Filter Assembly

Ideal for applications requiring dry and extremely clean air. Designed for air compressors rated up to 3.5 CFM. Prefilter removes liquid and solid particles down to 5 microns; coalescing filter removes particles down to 0.01 micron. Use optional bracket to mount on wall or bench. Maximum inlet pressure: 150 PSI. Ports: 1/4".

Description	Item#	Each
<b>A.</b> Filter Assembly	<b>850-7353</b>	<b>\$78.00</b>
Mounting Bracket	<b>850-7359</b>	<b>6.50</b>
Replacement Prefilter (white)	850-7337	9.30
Replacement Coalescing Filter (green)	850-7357	35.35



**B**

### **B** Miniature Filter/Regulator-Lubricator Assembly

Combines functions of filter, regulator and lubricator. General-purpose filter removes solid and liquid particles down to 5 microns. Regulator allows outlet pressure adjustment from 5 to 100 PSI. Micro-fog lubricator provides oil mist to lubricate moving parts of air hand-pieces. Has 1 oz. reservoir. Use optional bracket to mount on wall or bench. Maximum inlet pressure: 150 PSI. Ports: 1/8".

Description	Item#	Each
<b>B.</b> Filter Assembly*	<b>850-7349</b>	<b>\$107.05</b>
Mounting Bracket	<b>850-7335</b>	<b>8.50</b>
Replacement Filter	850-7369	7.75

*\*This device is suitable for all air tools except NSK Presto Air Turbine.*



**C**

### **C** Miniature Filter/Regulator

Combines the functions of filter and regulator. Filter removes solid and liquid particles in compressed air down to 5 microns. Regulator allows outlet pressure adjustment from 5 to 100 PSI. Maintains nearly constant outlet pressure despite changes in inlet pressure. Use optional bracket to mount on wall or bench. Maximum inlet pressure: 150 PSI. Ports: 1/4".

Description	Item#	Each
<b>C.</b> Filter Assembly	<b>850-7333</b>	<b>\$63.35</b>
Mounting Bracket	<b>850-7335</b>	<b>8.50</b>
Replacement Filter	850-7369	7.75



**D**

### **D** Large Prefilter/Coalescing Filter Assembly

Designed for large air compressors rated up to 15 CFM. Ideal for applications requiring greater airflow. Prefilter removes liquid and solid particles down to 5 microns; coalescing filter removes particles down to 0.01 microns. Requires regulator for use with most air tools. Use optional bracket to mount on wall or bench. Maximum inlet pressure: 150 PSI. Ports: 1/4".

Description	Item#	Each
<b>D.</b> Filter Assembly	<b>850-7355</b>	<b>\$119.00</b>
Mounting Bracket	<b>850-7367</b>	<b>17.35</b>
Replacement Prefilter (white)	850-7337	9.30
Replacement Coalescing Filter (green)	850-7365	45.65



**A - L Quick-Disconnect Air Hose and Fittings**

Sturdy 1/4" O.D. nylon air hose with .040" wall thickness and timesaving quick-disconnect fittings. To connect, just push air hose into fitting—it automatically locks in place. To disconnect, push back plastic ring on fitting and pull air hose out. Use 1/4" male fittings for air filters and regulators.

Description	Item#	Per Foot
<b>A.</b> Nylon Air Hose, 1/4" O.D.	<b>265-2286</b>	<b>\$.94</b>
Description	Item#	Each
<b>B.</b> QD Connector, Male, 1/4"	<b>265-2276</b>	<b>\$6.85</b>
<b>C.</b> QD Swivel Elbow, Male, 1/4"	<b>265-2293</b>	<b>7.05</b>
<b>D.</b> QD Elbow, Male, 1/4"	<b>265-2288</b>	<b>7.80</b>
<b>E.</b> QD Swivel Elbow, Male, 1/8"	<b>265-2291</b>	<b>5.96</b>
<b>F.</b> QD Swivel T-Connector, Male, 1/4"	<b>265-2278</b>	<b>7.70</b>
<b>G.</b> QD Connector, Male, 1/8"	<b>265-2277</b>	<b>3.75</b>
<b>H.</b> Nipple Reducer, 1/4"-1/8"	<b>265-2289</b>	<b>2.65</b>
<b>I.</b> Plug for QD 1/4" Connectors	<b>265-2283</b>	<b>1.60</b>
<b>J.</b> Coupling, Female, 1/4" to 1/4"	<b>265-2284</b>	<b>2.75</b>
<b>K.</b> QD Union (Straight), 1/4"	<b>265-2282</b>	<b>4.65</b>
<b>L.</b> QD Union T, 1/4"	<b>265-2281</b>	<b>6.65</b>
QD Union Elbow, 1/4"	<b>265-2279</b>	<b>5.50</b>

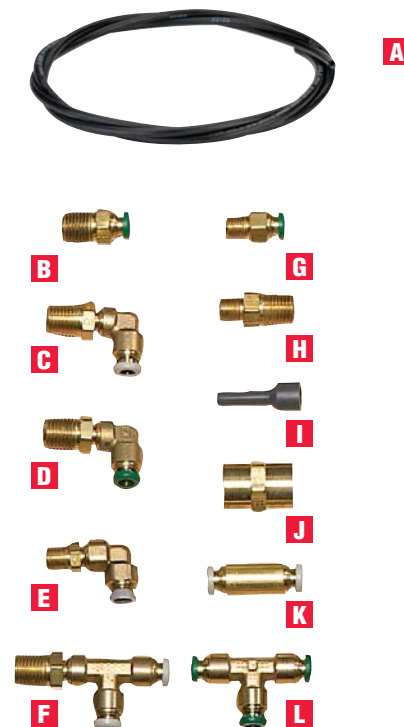

**M Variable Foot Control Pedal**

A disk-type foot control for use with any of our air handpieces. Sensitive and variably controls airflow from anywhere the disc is depressed. Low-profile, skid-resistant bottom. Complete with 5/32" hose and fittings.

Description	Item#	Each
Variable Foot Control Pedal	<b>850-7385</b>	<b>\$128.00</b>



**N Reinforced Air Hose with Fittings**

This 8' long 1/4" I.D. rubber hose comes with 1/8" NPT coupler and 1/4" NPT coupler. Withstands air pressures up to 250 PSI.

Description	Item#	Each
Reinforced Air Hose	<b>850-7323</b>	<b>\$21.00</b>



**O, P Barbed Fitting and Clamp**

Use clamp to fasten air hose securely to fitting.

Description	Item#	Each
<b>O.</b> Clamp	<b>265-2274</b>	<b>\$3.65</b>
<b>P.</b> 1/4" NPT Barbed Fitting	<b>265-2272</b>	<b>5.95</b>

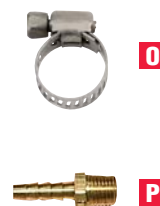

**Q Reinforced Air Hose**

Sturdy 1/4" I.D. rubber hose reinforced to withstand air pressures up to 250 PSI. Fits barbed fittings. Sold by the foot.

Description	Item#	Per Foot
Reinforced Air Hose	<b>265-2273</b>	<b>\$2.50</b>



## SUPRA® “MM” Brushes – Made in USA

Gesswein miniature mandrel-mounted wheel and cup brushes are made with solid steel ring construction for durability. Brush filaments are permanently anchored in the solid steel ring and uniformly distributed for even wear. Great for flat, curved, small and hard-to-reach surfaces. Hard and soft bristle types are made of animal hair. Maximum operating speed: 25,000rpm. \*Asterisked items also available on 3mm shanks.

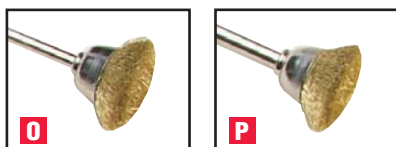
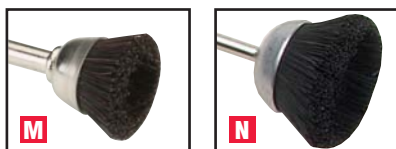
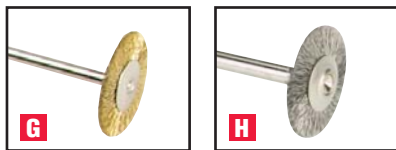
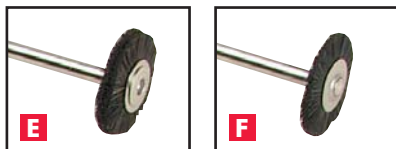
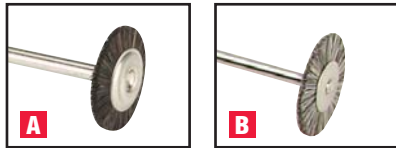

### A - F SUPRA® “MM” Bristle Wheel Brushes

Styles 701D and 711D each contain two rows of converging bristles. Styles 702 and 712 each contain two rows of upright bristles.

Style	Bristle Type	Shank	Trim Length	Diameter	Item#	DOZEN Prices 1-11	12+
710	Hard	3/32"	1/8"	9/16"	<b>112-7100</b>	<b>\$8.50</b>	<b>\$7.08</b>
<b>A. 700</b>	Soft	3/32"	1/8"	9/16"	<b>112-7000</b>	<b>9.25</b>	<b>7.71</b>
<b>B. 711</b>	Hard/Silver	3/32"	3/16"	3/4"	<b>112-7110</b>	<b>6.25</b>	<b>5.21</b>
711	Hard/Black	3/32"	3/16"	3/4"	<b>112-7109</b>	<b>5.50</b>	<b>4.58</b>
<b>C. 711D</b>	Hard	3/32"	3/16"	3/4"	<b>112-7111</b>	<b>23.50</b>	<b>19.58</b>
<b>D. 701</b>	Soft	3/32"	3/16"	3/4"	<b>112-7010</b>	<b>7.25</b>	<b>6.04</b>
701D	Soft	3/32"	3/16"	3/4"	<b>112-7011</b>	<b>34.90</b>	<b>29.08</b>
<b>E. 712D</b>	Hard	1/8"	3/16"	3/4"	<b>112-7120</b>	<b>34.90</b>	<b>29.08</b>
702	Soft	1/8"	3/16"	3/4"	<b>112-7020</b>	<b>43.60</b>	<b>36.33</b>
<b>F. 713*</b>	Hard	1/8"	3/16"	3/4"	<b>112-7130</b>	<b>10.80</b>	<b>9.00</b>
703*	Soft	1/8"	3/16"	3/4"	<b>112-7030</b>	<b>13.30</b>	<b>11.80</b>

### G - J SUPRA® “MM” Wire Wheel Brushes

All made of .003" diameter crimped wire except #112-7315, which is made of .005" diameter crimped wire. Styles 722 and 732 each contain two rows of upright bristles.

Style	Wire Type	Shank	Trim Length	Diameter	Item#	DOZEN Prices 1-11	12+
<b>G. 721</b>	Brass	3/32"	3/16"	3/4"	<b>112-7210</b>	<b>\$25.60</b>	<b>\$21.33</b>
731	Steel	3/32"	3/16"	3/4"	<b>112-7310</b>	<b>24.40</b>	<b>20.33</b>
<b>H. 731</b>	Stainless	1/8"	3/16"	3/4"	<b>112-7315</b>	<b>35.30</b>	<b>29.42</b>
<b>I. 722</b>	Brass	1/8"	3/16"	3/4"	<b>112-7220</b>	<b>75.25</b>	<b>62.71</b>
732	Steel	1/8"	3/16"	3/4"	<b>112-7320</b>	<b>71.50</b>	<b>59.58</b>
<b>J. 723*</b>	Brass	1/8"	3/16"	3/4"	<b>112-7230</b>	<b>24.95</b>	<b>20.79</b>
733*	Steel	1/8"	3/16"	3/4"	<b>112-7330</b>	<b>24.95</b>	<b>20.79</b>

### K - N SUPRA® “MM” Bristle Cup Brushes

Style	Wire Type	Shank	Trim Length	Diameter	Item#	DOZEN Prices 1-11	12+
<b>K. 760</b>	Hard	3/32"	5/32"	1/2"	<b>112-7600</b>	<b>\$10.45</b>	<b>\$8.71</b>
750	Soft	3/32"	5/32"	1/2"	<b>112-7500</b>	<b>12.20</b>	<b>10.17</b>
<b>L. 761</b>	Hard	3/32"	1/4"	9/16"	<b>112-7610</b>	<b>11.85</b>	<b>9.87</b>
751	Soft	3/32"	1/4"	9/16"	<b>112-7510</b>	<b>12.75</b>	<b>10.62</b>
<b>M. 762*</b>	Hard	1/8"	1/4"	9/16"	<b>112-7620</b>	<b>10.45</b>	<b>8.71</b>
752*	Soft	1/8"	1/4"	9/16"	<b>112-7520</b>	<b>11.90</b>	<b>9.92</b>
<b>N. 764*</b>	Hard	1/8"	7/16"	1"	<b>112-7640</b>	<b>43.95</b>	<b>36.62</b>
754*	Soft	1/8"	7/16"	1"	<b>112-7540</b>	<b>53.50</b>	<b>44.58</b>

### O, P SUPRA® “MM” Wire Cup Brushes

All made of .003" diameter crimped wire except #112-7825, which is made of .005" diameter crimped wire.

Style	Wire Type	Shank	Trim Length	Diameter	Item#	DOZEN Prices 1-11	12+
<b>O. 771</b>	Brass	3/32"	3/16"	9/16"	<b>112-7710</b>	<b>\$29.85</b>	<b>\$24.87</b>
781	Steel	3/32"	3/16"	9/16"	<b>112-7810</b>	<b>28.60</b>	<b>23.83</b>
<b>P. 772*</b>	Brass	1/8"	3/16"	9/16"	<b>112-7720</b>	<b>28.95</b>	<b>24.12</b>
782*	Steel	1/8"	1/4"	5/8"	<b>112-7820</b>	<b>28.95</b>	<b>24.12</b>
782	Stainless	1/8"	1/4"	5/8"	<b>112-7825</b>	<b>65.50</b>	<b>54.58</b>

**SUPRA® “ME” Brushes – Made in USA**

Gesswein miniature mandrel-mounted end brushes are available in a wide variety of sizes. One-piece ferrule construction ensures that the stem and ferrule will not become separated during use. Plastic ferrules are available to prevent scratching when used for interior polishing work. In the table below, please note that those brushes with a style number containing the letter “P” have plastic ferrules, which are slightly larger than stated diameter. All other ferrules are metal. Hard and soft bristle types are made of animal hair. Maximum operating speed: 25,000rpm. **\*Asterisked items also available on 3mm shanks.**

**A - H SUPRA® “ME” Bristle End Brushes**

Style	Bristle Type	Shank	Trim Length	Ferrule Diameter	Item#	DOZEN Prices	
						1-11	12+
<b>A.</b> 864	Hard	3/32"	1/4"	5/32"	<b>110-8640</b>	<b>\$9.60</b>	<b>\$8.00</b>
<b>B.</b> 860	Hard	3/32"	1/4"	3/16"	<b>110-8600</b>	<b>6.55</b>	<b>5.46</b>
860 <sup>3/8</sup>	Hard	3/32"	3/8"	3/16"	<b>110-8603</b>	<b>7.90</b>	<b>6.58</b>
860 <sup>1/2</sup>	Hard	3/32"	1/2"	3/16"	<b>110-8605</b>	<b>8.25</b>	<b>6.87</b>
850	Soft	3/32"	1/4"	3/16"	<b>110-8500</b>	<b>16.65</b>	<b>13.87</b>
<b>C.</b> 861	Hard	3/32"	3/8"	1/4"	<b>110-8610</b>	<b>12.95</b>	<b>10.79</b>
861 <sup>1/2</sup>	Hard	3/32"	1/2"	1/4"	<b>110-8615</b>	<b>13.95</b>	<b>11.62</b>
851	Soft	3/32"	3/8"	1/4"	<b>110-8510</b>	<b>23.40</b>	<b>19.50</b>
<b>D.</b> 859*	Hard	1/8"	1/4"	3/16"	<b>110-8590</b>	<b>7.50</b>	<b>6.25</b>
<b>E.</b> 859P	Hard	1/8"	1/4"	3/16"	<b>111-8590</b>	<b>8.60</b>	<b>7.17</b>
849*	Soft	1/8"	1/4"	3/16"	<b>110-8490</b>	<b>11.85</b>	<b>9.87</b>
849P	Soft	1/8"	1/4"	3/16"	<b>111-8490</b>	<b>17.35</b>	<b>14.46</b>
<b>F.</b> 862*	Hard	1/8"	3/8"	1/4"	<b>110-8620</b>	<b>12.95</b>	<b>10.79</b>
<b>G.</b> 862P	Hard	1/8"	3/8"	1/4"	<b>111-8620</b>	<b>12.70</b>	<b>10.58</b>
862 <sup>1/2</sup>	Hard	1/8"	1/2"	1/4"	<b>110-8625</b>	<b>14.55</b>	<b>12.12</b>
862 <sup>3/4</sup>	Hard	1/8"	3/4"	1/4"	<b>110-8627</b>	<b>20.35</b>	<b>16.96</b>
852	Soft	1/8"	3/8"	1/4"	<b>110-8520</b>	<b>24.45</b>	<b>20.37</b>
852P	Soft	1/8"	3/8"	1/4"	<b>111-8520</b>	<b>22.95</b>	<b>19.12</b>
<b>H.</b> 962*	Hard	1/8"	9/16"	5/16"	<b>110-9620</b>	<b>18.20</b>	<b>15.17</b>



**I - L SUPRA® “ME” Wire End Brushes**

All made of .003" diameter straight wire except #110-8795, #110-8720, #110-8820, #110-9720 and #110-9820, which are made of .005" diameter crimped wire.

Style	Wire Type	Shank	Trim Length	Ferrule Diameter	Item#	DOZEN Prices	
						1-11	12+
<b>I.</b> 870	Brass	3/32"	1/4"	3/16"	<b>110-8700</b>	<b>\$13.75</b>	<b>\$11.46</b>
880	Steel	3/32"	1/4"	3/16"	<b>110-8800</b>	<b>13.30</b>	<b>11.08</b>
<b>J.</b> 869	Brass	1/8"	1/4"	3/16"	<b>110-8690</b>	<b>13.75</b>	<b>11.46</b>
879	Steel	1/8"	1/4"	3/16"	<b>110-8790</b>	<b>13.30</b>	<b>11.08</b>
879	Stainless	1/8"	1/4"	3/16"	<b>110-8795</b>	<b>28.60</b>	<b>23.83</b>
<b>K.</b> 872	Brass	1/8"	7/16"	1/4"	<b>110-8720</b>	<b>34.90</b>	<b>29.08</b>
882	Steel	1/8"	7/16"	1/4"	<b>110-8820</b>	<b>33.90</b>	<b>28.25</b>
882	Stainless	1/8"	7/16"	1/4"	<b>110-8823</b>	<b>42.40</b>	<b>35.33</b>
<b>L.</b> 972	Brass	1/8"	9/16"	5/16"	<b>110-9720</b>	<b>38.40</b>	<b>32.00</b>
982	Steel	1/8"	9/16"	5/16"	<b>110-9820</b>	<b>38.40</b>	<b>32.00</b>



**M SUPRA® Introductory Brush Sets**

Try these 12-piece sets of our most popular SUPRA brushes. Set #1 (3/32" shank set) includes assortment of bristle and wire cup, wheel and end brushes. Set #2 (1/8" shank set) includes bristle cup and end brushes with both plastic and metal ferrules.

Description	Shank	Ferrule Type	Item#	Each
Set #1	3/32"	Metal	<b>112-8000</b>	<b>\$11.75</b>
<b>M.</b> Set #2	1/8"	Metal and plastic	<b>112-8003</b>	<b>17.50</b>





### A SUPRA® "MKM" Bristle Wheel Brushes – 1/8" Shank

Made of converging hard Chungking (animal-hair) bristles evenly mounted on 1/8" shanks. The 1" diameter is a brush of standard thickness, and the 1 1/4" diameter is a double-thick brush. Maximum operating speed: 25,000rpm. Made in USA.

Bristle Type	Shank	Trim Length	Diameter	Item#	DOZEN Prices	
					1-11	12+
Hard	1/8"	1/4"	1"	<b>112-5100</b>	<b>\$22.30</b>	<b>\$18.58</b>
Hard	1/8"	3/8"	1 1/4"	<b>112-5200</b>	<b>63.65</b>	<b>53.04</b>



### B, C SUPRA® "MKM" Wire Wheel Brushes – 1/8" Shank

All made of .005" diameter crimped wire except #112-5110, which is made of .003" diameter straight wire. Max. operating speed: 25,000rpm. Made in USA.

Wire Type	Shank	Trim Length	Diameter	Item#	DOZEN Prices	
					1-11	12+
<b>B.</b> Stainless	1/8"	1/8"	5/8"	<b>112-5105</b>	<b>\$28.90</b>	<b>\$24.08</b>
<b>C.</b> Stainless	1/8"	1/4"	1"	<b>112-5115</b>	<b>36.95</b>	<b>30.79</b>
Stainless	1/8"	1/4"	1"	<b>112-5110</b>	<b>42.40</b>	<b>35.33</b>



### D EL-192 Bristle Wheel Brush

Hard Chungking (animal-hair) brush with bristles that are tightly packed, providing suitable stiffness while performing much better than individually tufted brushes. Lead center ensures secure retention on a tapered spindle. Maximum operating speed: 3,450rpm. Made in USA.

Type	Trim Length	Brush Dia.	Rows	Item#	EACH Prices		
					1-11	12-143	144+
Hard	9/16"	2"	2	<b>114-5192</b>	<b>\$5.15</b>	<b>\$4.29</b>	<b>\$3.61</b>



### E - G SUPRA "MK"® Bristle Wheel Brushes – 1/8" Arbor Hole

These very popular SUPRA MK unmounted wheel brushes are made with solid ring construction for durability. They run true, have plenty of evenly distributed bristles for uniform wear and are long-lasting. When mounted on our unbreakable MK Plastic Spindles, MK Brushes can be changed in seconds, thereby speeding up production. May also be mounted on mandrels #20 and #22 (see p. 131). Each has brass hub with 1/8" arbor hole. Maximum operating speed: 25,000rpm. Made in USA.

Bristle Type	Arbor Hole	Trim Length	Diameter	Item#	DOZEN Prices		
					1-11	12+	12+
<b>E.</b> Hard	1/8"	1/8"	5/8"	<b>113-0100</b>	<b>\$5.25</b>	<b>\$4.37</b>	
Medium	1/8"	1/8"	5/8"	<b>113-0150</b>	<b>5.00</b>	<b>4.17</b>	
Soft	1/8"	1/8"	5/8"	<b>113-0250</b>	<b>5.95</b>	<b>4.96</b>	
<b>F.</b> Hard	1/8"	3/16"	3/4"	<b>113-0400</b>	<b>4.90</b>	<b>4.08</b>	
Medium	1/8"	3/16"	3/4"	<b>113-0500</b>	<b>4.90</b>	<b>4.08</b>	
Soft	1/8"	3/16"	3/4"	<b>113-0600</b>	<b>5.30</b>	<b>4.42</b>	
<b>G.</b> Hard	1/8"	1/4"	1"	<b>113-0800</b>	<b>5.55</b>	<b>4.62</b>	
Medium	1/8"	1/4"	1"	<b>113-0850</b>	<b>5.55</b>	<b>4.62</b>	
Soft	1/8"	1/4"	1"	<b>113-0950</b>	<b>6.90</b>	<b>5.75</b>	



### H Plastic Spindles for SUPRA "MK"® Bristle Wheel Brushes

Steel threaded mandrel mounted in a hard plastic spindle base. Accommodates all SUPRA MK brushes. Fits on a tapered spindle. Mounting of brush is easy – requires only slight pressure and a quarter-turn. Choose for right or left shaft on motor.

For	Color	Item#	Each
<b>H.</b> Left	Black	<b>840-4900</b>	<b>\$11.95</b>
Right	White	<b>840-4950</b>	<b>11.95</b>



**A Wood Hub Bristle Wheel Brushes – 1/4" Arbor Hole**

Our standard high-quality wheel brushes marked with a blue imprint. These superior brushes are made of hard Chungking (animal-hair) bristles securely mounted in hardwood hubs. Those with two or more rows of bristles are converging type. Each has 1/4" arbor hole. For use on tapered spindles. Made in USA.

Gesswein Style	Trim Length	Rows of Bristles	Overall Dia.	Item#	EACH Prices			
					1-11	12-71	72-143	144+
53	5/8"	1	2 1/2"	<b>115-1530</b>	<b>\$1.15</b>	<b>\$.92</b>	<b>\$.86</b>	<b>\$.81</b>
54 SC	3/8"	2	2"	<b>115-1540</b>	<b>1.50</b>	<b>1.20</b>	<b>1.13</b>	<b>1.05</b>
55	5/8"	2	2 1/2"	<b>115-1550</b>	<b>1.40</b>	<b>1.12</b>	<b>1.05</b>	<b>.98</b>
56	5/8"	3	2 1/2"	<b>115-1560</b>	<b>1.75</b>	<b>1.40</b>	<b>1.31</b>	<b>1.23</b>
57	5/8"	4	2 1/2"	<b>115-1570</b>	<b>2.50</b>	<b>2.00</b>	<b>1.88</b>	<b>1.75</b>
62	3/4"	2	3"	<b>115-1620</b>	<b>1.65</b>	<b>1.32</b>	<b>1.24</b>	<b>1.16</b>
63	3/4"	3	3"	<b>115-1630</b>	<b>2.20</b>	<b>1.76</b>	<b>1.65</b>	<b>1.54</b>
64	3/4"	4	3"	<b>115-1640</b>	<b>2.45</b>	<b>1.96</b>	<b>1.84</b>	<b>1.72</b>
70 SC	3/8"	1	2 5/8"	<b>115-1700</b>	<b>1.30</b>	<b>1.04</b>	<b>.98</b>	<b>.91</b>
71	5/8"	1	3 5/8"	<b>115-1710</b>	<b>1.35</b>	<b>1.08</b>	<b>1.01</b>	<b>.95</b>
72 SC	3/8"	2	2 5/8"	<b>115-1720</b>	<b>1.75</b>	<b>1.40</b>	<b>1.31</b>	<b>1.23</b>
73	5/8"	2	3 1/8"	<b>115-1730</b>	<b>1.80</b>	<b>1.44</b>	<b>1.35</b>	<b>1.26</b>
73 SC	1/2"	2	3"	<b>115-1732</b>	<b>1.80</b>	<b>1.44</b>	<b>1.35</b>	<b>1.26</b>

*SC refers to short cut bristles, which give more aggressive brushing action.*



**B Economy Bristle Wheel Brushes – 1/4" Arbor Hole**

Marked with a black imprint. Top-quality wood hubs with Chungking (animal-hair) bristles almost as stiff as our top-of-the-line blue imprint brushes. All converging except IE-B and 70E SC. Each has 1/4" arbor hole. For use on tapered spindles. Made in USA.

Gesswein Style	Trim Length	Rows of Bristles	Overall Dia.	Item#	EACH Prices		
					12-60	72-132	144+
54E SC	3/8"	2	2"	<b>115-1800</b>	<b>\$1.05</b>	<b>\$.95</b>	<b>\$.84</b>
1E-B	1/2"	1	2 7/8"	<b>115-1803</b>	<b>.85</b>	<b>.77</b>	<b>.68</b>
70E SC	3/8"	1	2 5/8"	<b>115-1805</b>	<b>.80</b>	<b>.72</b>	<b>.64</b>
72E SC	3/8"	2	2 5/8"	<b>115-1810</b>	<b>1.10</b>	<b>.99</b>	<b>.88</b>
73E	5/8"	2	3 1/8"	<b>115-1815</b>	<b>1.15</b>	<b>1.04</b>	<b>.92</b>
73E SC	1/2"	2	3"	<b>115-1820</b>	<b>1.15</b>	<b>1.04</b>	<b>.92</b>

*SC refers to short cut bristles, which give more aggressive brushing action. Twelve-piece minimum; please order in multiples of 12.*



**C Plastic Hub Bristle Wheel Brushes – 1/4" Arbor Hole**

Made of extra-hard, premium-quality Chungking (animal-hair) bristles securely mounted in narrow, unbreakable plastic hubs. Bristles converge exceptionally well, eliminating the need to burn-in. Each has two rows of converging bristles and 1/2" thick hub with 1/4" arbor hole. For use on tapered spindles. Made in USA.

Gesswein Style	Trim Length	Rows of Bristles	Overall Dia.	Item#	EACH Prices			
					1-11	12-71	72-143	144+
54P SC	3/8"	2	2"	<b>115-1541</b>	<b>\$1.85</b>	<b>\$1.48</b>	<b>\$1.39</b>	<b>\$1.30</b>
55P	5/8"	2	2 1/2"	<b>115-1551</b>	<b>1.75</b>	<b>1.40</b>	<b>1.31</b>	<b>1.23</b>
72P SC	3/8"	2	2 5/8"	<b>115-1721</b>	<b>2.10</b>	<b>1.68</b>	<b>1.58</b>	<b>1.47</b>
73P	5/8"	2	3 1/8"	<b>115-1731</b>	<b>2.10</b>	<b>1.68</b>	<b>1.58</b>	<b>1.47</b>

*SC refers to short cut bristles, which give more aggressive brushing action.*



**Safety Recommendations**

For safe operation of motor-driven brushes, comply with the Safety Standards of the Industrial Division of the American Brush Manufacturers' Association and the American National Standards Institute ANSI B165.1-1991 "Safety Requirements – Power Brushes" and ANSI B165.2-1987 "Safety Requirements – Power Brushes – Wood, Plastic, or Composition Hubs."



## A - C Wire Wheel Scratch Brushes

Made of .003" diameter crimped wire with lead centers (except #116-4403 and #118-4403, which have plastic centers), ensuring retention on tapered spindles. Use for cleaning, light deburring and imparting a fine satin finish on nonferrous metals. Use brass on yellow metals, others on white. All have 1/4" arbor hole. Max. operating speed: 6,000rpm (except #116-4403 and #118-4403, which are 4,000rpm). Made in USA.

Type	Trim Length	Brush		Item#	EACH Prices	
		Dia.	Rows		1-11	12+
Brass	3/4"	2"	2	<b>116-2203</b>	<b>\$17.65</b>	<b>\$15.00</b>
<b>A.</b> Brass	1"	3"	2	<b>116-3203</b>	<b>15.85</b>	<b>13.47</b>
<b>B.</b> Steel	1"	3"	2	<b>117-3203</b>	<b>15.75</b>	<b>13.39</b>
<b>C.</b> Nickel Silver	1"	3"	2	<b>118-3203</b>	<b>15.95</b>	<b>13.56</b>
Brass	1"	3"	4	<b>116-3403</b>	<b>37.75</b>	<b>32.09</b>
Brass	1 1/4"	4"	4	<b>116-4403</b>	<b>38.50</b>	<b>32.73</b>
Nickel Silver	1 1/4"	4"	4	<b>118-4403</b>	<b>40.65</b>	<b>34.55</b>



## D - G Scratch Brush Pens

Handy and comfortable to hold. Brushes come in four different types: steel, nylon, fiberglass and brass. They are excellent for removing rust or corrosion and for reaching into narrow areas. Metal ferrule improves durability. Measure 4 1/2" long. Refills are 1 1/4" long. Made in Germany.

Description	Pen Item#	EACH Prices		Refill Item#	PKG. of 6	
		1-2	3+		1-2	3+
<b>D.</b> Stainless	<b>115-2310</b>	<b>\$7.25</b>	<b>\$6.89</b>	<b>115-2311</b>	<b>\$5.25</b>	<b>\$4.99</b>
<b>E.</b> Nylon	<b>115-2312</b>	<b>6.45</b>	<b>6.13</b>	<b>115-2313</b>	<b>3.75</b>	<b>3.56</b>
<b>F.</b> Fiberglass	<b>115-2314</b>	<b>6.45</b>	<b>6.13</b>	<b>115-2315</b>	<b>4.50</b>	<b>4.28</b>
<b>G.</b> Brass	<b>115-2316</b>	<b>7.25</b>	<b>6.89</b>	<b>115-2317</b>	<b>4.75</b>	<b>4.51</b>



## H, I Wire Brushes with Plastic Handles

Use on metals for intermediate finishing, surface preparation or final finishing. Ideal for cleaning bur teeth and for scrubbing and removing carbon buildup found in EDM cavities. Can also be used for texturing. Available with .006" dia. x 7/16"L stainless steel or .004" dia. x 7/16"L brass wire bristles. Both have plastic handles. Measure 7 1/4" long.

Wire Type	Face Dimensions (L x W)	Item#	EACH Prices	
			1-11	12+
<b>H.</b> Stainless Steel	1 3/8" x 1/4"	<b>114-5300</b>	<b>\$1.95</b>	<b>\$1.62</b>
<b>I.</b> Brass	1 3/8" x 1/4"	<b>114-5305</b>	<b>2.70</b>	<b>2.25</b>



## J, K Hand-Laced Scratch Brushes

Feature three rows of flexible bristles ideal for producing a satin finish and cleaning detailed work. Hand-laced with stainless steel wire to retain maximum bristles and allow handle expansion and contraction when exposed to wetness. Available in brass and stainless steel. Measure 7 3/4"L with 0.003" dia. x 7/16"L bristles.

Description	Item#	Each
<b>J.</b> Brass	<b>114-5315</b>	<b>\$5.95</b>
<b>K.</b> Stainless Steel	<b>114-5320</b>	<b>6.75</b>



## L Double-Ended Brush - Stainless Steel Wire

One end has .005" dia. straight stainless steel bristles, 1/4" trim, 3/16" dia. The other end has .003" dia. crimped stainless steel bristles, 7/16" trim, 1/4" dia. Wooden handle has finger grip at both ends. Measures 6" overall length.

Material	Handle		Item#	EACH Prices	
	Length	Style		1-11	12+
Wood	6"	7982	<b>114-5310</b>	<b>\$8.90</b>	<b>\$7.42</b>

**A Brass Scratch Brush**

Used to produce a fine satin finish on soft yellow metals or to prepare surfaces for another process. Has four rows of .004" diameter brass wire measuring 3/4" in length and securely anchored in a wooden handle. Measures 8 1/2" overall length.

Description	Face Dimensions (L x W)	Item#	EACH Prices		
			1-11	12+	
Brass Scratch	3 1/4" x 5/8"	<b>118-3400</b>	<b>\$7.80</b>	<b>\$6.63</b>	



**A**

**B Bench Duster**

Contains four rows of 1 1/2" long natural bristles in a wooden handle. Ideal for cleaning dust from surfaces and for general-purpose work. Measures 9 3/4" overall length.

Description	Face Dimensions (L x W)	Item#	EACH Prices		
			1-2	3-11	12+
Bench Duster	4" x 3/4"	<b>115-2260</b>	<b>\$8.60</b>	<b>\$7.74</b>	<b>\$6.88</b>



**B**

**C Soft Watchmaker's Brush**

Contains four rows of 5/8" long natural bristles in a wooden handle. Recommended for cleaning and dusting clocks and instruments and for general-purpose work. Measures 10 1/4" overall length.

Description	Face Dimensions (L x W)	Item#	EACH Prices		
			1-2	3-11	12+
Watchmaker's	4 1/2" x 1/2"	<b>115-2340</b>	<b>\$5.40</b>	<b>\$4.86</b>	<b>\$4.32</b>



**C**

**D Washout Brushes with Lucite Handles**

Both have extra-stiff natural bristles in lucite handles. Three-Row Brush has 5/8" long bristles. Four-Row Brush has 3/4" long bristles. Measure 7 1/4" overall length.

Description	Face Dimensions (L x W)	Item#	EACH Prices		
			1-2	3-11	12+
<b>D. 3-Row</b>	3 1/2" x 1/2"	<b>115-2060</b>	<b>\$5.51</b>	<b>\$4.96</b>	<b>\$4.41</b>
4-Row	3 1/4" x 3/4"	<b>115-2070</b>	<b>5.90</b>	<b>5.31</b>	<b>4.72</b>



**D**

**E Washout Brushes with Wooden Handles**

Both have four rows of 3/4" long natural bristles in wooden handles. Short-Face Brush has extra-stiff bristles. Regular Brush has stiff bristles. Measure 8 1/4" overall length.

Description	Face Dimensions (L x W)	Item#	EACH Prices		
			1-2	3-11	12+
<b>E. Short-Face</b>	2" x 1/2"	<b>115-2100</b>	<b>\$4.90</b>	<b>\$4.41</b>	<b>\$3.92</b>
Regular	3 1/2" x 3/4"	<b>115-2200</b>	<b>5.25</b>	<b>4.73</b>	<b>4.20</b>



**E**

**F Small Washout Brush**

This brush is ideal for cleaning small areas. It has four rows of 1/2" long, extra-stiff nylon bristles in an angled plastic handle. Measures 6 5/8" overall length.

Description	Face Dimensions (L x W)	Item#	EACH Prices		
			1-2	3-11	12+
Washout	1 3/4" x 1/2"	<b>115-2250</b>	<b>\$2.25</b>	<b>\$2.03</b>	<b>\$1.80</b>



**F**

**G - J Nylon Tube Brushes**

Single-stem, single-spiral nylon tube brushes designed for cleaning inner diameters of pipes and tubes as well as grooves and keyways. Each has loop handle for sure grip. Available in four sizes.

Overall Length	Brush Size (L x Dia.)	Item#	EACH Prices		
			1-2	3-11	12+
<b>G. 12 1/4"</b>	4" x 1"	<b>115-2285</b>	<b>\$3.49</b>	<b>\$3.14</b>	<b>\$2.79</b>
<b>H. 8 1/2"</b>	3" x 3/4"	<b>115-2280</b>	<b>1.99</b>	<b>1.79</b>	<b>1.59</b>
<b>I. 8 1/2"</b>	3" x 1/2"	<b>115-2275</b>	<b>1.79</b>	<b>1.61</b>	<b>1.43</b>
<b>J. 6 1/4"</b>	2" x 1/4"	<b>115-2270</b>	<b>1.49</b>	<b>1.34</b>	<b>1.19</b>



**G**

**H**

**I**

**J**



## Buff Selection Guide

When used with compounds, buffs can do everything from removing deep scratches to imparting a high luster. Remember, each buff *must* be reserved for use with just one compound to avoid mixtures, which yield unpredictable finishes.

• **Loose Muslin Buffs** – Feature layers joined only at arbor hole. Offer soft action and follow contours. Use with rouge for final polishing. Have high linen content, which provides longer buff life compared to inexpensive competitive products.

- **Stitched Muslin Buffs** – Have multiple concentric circles of stitching for firmer action. Use with cutting compounds.
- **Razor-Edge Muslin Buffs** – Ideal for reaching areas conventional buffs can't.
- **Coarse-Weave Muslin** – Holds compounds very well.
- **Fine-Weave Muslin** – Holds compounds very well and has long life span.
- **Combed Edges** – Hold compounds well. Require no break-in period.

- **Treatments** – Chemical treatments make buffs stiffer and provide better compound retention. Use with cutting compounds on hard metals.
- **Centers** – Made of stitched leather or lead. Can also be shellac-hardened. For use on tapered spindles or arbors.
- **Unique Materials** – Flannel, chamois, cotton string and felt are used to produce buffs with different characteristics.

### A Stitched White Muslin Buffs – With Leather Centers

Made of fine-weave muslin with combed edges and leather centers. Thread count: 80/80.



Dia. x Ply	Rows of Stitching	Item#	EACH Prices		
			1-11	12-35	36+
3" x 40	3	<b>140-2300</b>	<b>\$1.89</b>	<b>\$1.70</b>	<b>\$1.51</b>
4" x 40	3	<b>140-2400</b>	<b>2.25</b>	<b>2.03</b>	<b>1.80</b>
4" x 50	3	<b>140-2450</b>	<b>2.70</b>	<b>2.43</b>	<b>2.16</b>
4" x 60	3	<b>140-2455</b>	<b>3.47</b>	<b>3.12</b>	<b>2.78</b>
5" x 45	3	<b>140-2500</b>	<b>3.32</b>	<b>2.99</b>	<b>2.66</b>
5" x 50	3	<b>140-2550</b>	<b>3.47</b>	<b>3.12</b>	<b>2.78</b>
6" x 50	4	<b>140-2650</b>	<b>4.66</b>	<b>4.19</b>	<b>3.73</b>
6" x 60	4	<b>140-2660</b>	<b>5.33</b>	<b>4.80</b>	<b>4.26</b>
7" x 50	4	<b>140-2700</b>	<b>5.71</b>	<b>5.14</b>	<b>4.57</b>
8" x 55	4	<b>140-2800</b>	<b>6.45</b>	<b>5.81</b>	<b>5.16</b>

### B Stitched Coarse Muslin Buffs – With Shellac Centers

Made of loose-weave muslin with shellac-hardened centers. Edges are not combed. Thread count: 60/60.



Dia. x Ply	Rows of Stitching	Item#	EACH Prices		
			1-11	12-35	36+
4" x 40	3	<b>140-2000</b>	<b>\$1.61</b>	<b>\$1.45</b>	<b>\$1.29</b>
5" x 45	3	<b>140-2010</b>	<b>2.31</b>	<b>2.08</b>	<b>1.85</b>
6" x 50	4	<b>140-2020</b>	<b>3.36</b>	<b>3.02</b>	<b>2.69</b>

### C Loose White Muslin Buffs – With Leather Centers

Made of fine-weave muslin with combed edges and leather centers. Thread count: 80/80.



Dia. x Ply	Item#	EACH Prices		
		1-11	12-35	36+
3" x 40	<b>140-4300</b>	<b>\$1.71</b>	<b>\$1.54</b>	<b>\$1.37</b>
4" x 40	<b>140-4400</b>	<b>2.09</b>	<b>1.88</b>	<b>1.67</b>
4" x 50	<b>140-4350</b>	<b>2.56</b>	<b>2.30</b>	<b>2.05</b>
5" x 45	<b>140-4500</b>	<b>2.92</b>	<b>2.63</b>	<b>2.34</b>
6" x 50	<b>140-4650</b>	<b>4.56</b>	<b>4.10</b>	<b>3.65</b>
6" x 60	<b>140-4660</b>	<b>5.01</b>	<b>4.51</b>	<b>4.01</b>
7" x 50	<b>140-4700</b>	<b>5.25</b>	<b>4.73</b>	<b>4.20</b>
8" x 55	<b>140-4800</b>	<b>5.82</b>	<b>5.24</b>	<b>4.66</b>

### D Loose White Muslin Buffs – 3/8" Arbor Hole

Made of fine-weave muslin with combed edges. All have 3/8" diameter arbor holes for use on 3/8" arbor shaft. Not for use on tapered spindles. Thread count: 80/80.



Dia. x Ply	Item#	EACH Prices		
		1-11	12-35	36+
3" x 20	<b>140-4315</b>	<b>\$.74</b>	<b>\$.67</b>	<b>\$.59</b>
4" x 20	<b>140-4320</b>	<b>.93</b>	<b>.84</b>	<b>.74</b>
5" x 20	<b>140-4420</b>	<b>1.32</b>	<b>1.19</b>	<b>1.06</b>
6" x 20	<b>140-4520</b>	<b>1.37</b>	<b>1.23</b>	<b>1.10</b>



**A Loose White Muslin Buffs – With Lead Centers**

Made of fine-weave muslin with combed edges and lead centers. A tapered spindle will create threads in the lead, providing a positive seat. Thread count: 80/80.

Dia. x Ply	Item#	EACH Prices		
		1-11	12-35	36+
3" x 36	<b>140-6330</b>	<b>\$3.01</b>	<b>\$2.71</b>	<b>\$2.41</b>
3" x 54	<b>140-6350</b>	<b>3.34</b>	<b>3.01</b>	<b>2.67</b>
4" x 54	<b>140-6450</b>	<b>3.94</b>	<b>3.55</b>	<b>3.15</b>
5" x 54	<b>140-6500</b>	<b>4.73</b>	<b>4.26</b>	<b>3.78</b>
6" x 54	<b>140-6650</b>	<b>5.63</b>	<b>5.07</b>	<b>4.50</b>
6" x 63	<b>140-6560</b>	<b>6.15</b>	<b>5.54</b>	<b>4.92</b>



**B Stitched Yellow Muslin Buffs – With Leather Centers**

Made of chemically treated fine-weave muslin with combed edges and leather centers. Feature a degree of stiffness that serves particularly well for cutting with tripoli. Last two to three times longer than white muslin buffs. Thread count: 86/80.

Dia. x Ply	Rows of Stitching	Item#	EACH Prices		
			1-11	12-35	36+
4" x 40	3	<b>141-2400</b>	<b>\$2.97</b>	<b>\$2.67</b>	<b>\$2.38</b>
4" x 50	3	<b>141-8700</b>	<b>3.17</b>	<b>2.85</b>	<b>2.54</b>
5" x 45	3	<b>141-2500</b>	<b>3.98</b>	<b>3.58</b>	<b>3.18</b>
5" x 50	3	<b>141-8710</b>	<b>3.93</b>	<b>3.54</b>	<b>3.14</b>
6" x 30	4	<b>141-8720</b>	<b>3.40</b>	<b>3.06</b>	<b>2.72</b>
6" x 50	4	<b>141-2600</b>	<b>5.06</b>	<b>4.55</b>	<b>4.05</b>
6" x 60	4	<b>141-2650</b>	<b>6.07</b>	<b>5.46</b>	<b>4.86</b>
7" x 50	4	<b>141-8730</b>	<b>6.97</b>	<b>6.27</b>	<b>5.58</b>
7" x 60	4	<b>141-8735</b>	<b>7.65</b>	<b>6.89</b>	<b>6.12</b>



**C Loose Yellow Muslin Buffs – With Leather Centers**

Made of the same chemically treated fine-weave muslin with combed edges and leather centers as our stitched yellow muslin buffs, but with no sewing. Can be used with rouge and work particularly well with cut-and-color compounds. Thread count: 86/80.

Dia. x Ply	Item#	EACH Prices		
		1-11	12-35	36+
4" x 50	<b>141-1000</b>	<b>\$2.73</b>	<b>\$2.46</b>	<b>\$2.18</b>
5" x 50	<b>141-1005</b>	<b>3.74</b>	<b>3.37</b>	<b>2.99</b>
6" x 50	<b>141-1010</b>	<b>4.79</b>	<b>4.31</b>	<b>3.83</b>



**D Loose Yellow Muslin Buffs – 3/8" Arbor Hole**

Made of the same chemically treated fine-weave muslin with combed edges as our other yellow buffs. All have 3/8" diameter arbor holes for use on 3/8" arbor shaft. Not for use on tapered spindles. Thread count: 86/80.

Dia. x Ply	Item#	EACH Prices		
		1-11	12-35	36+
4" x 20	<b>141-0995</b>	<b>\$1.26</b>	<b>\$1.13</b>	<b>\$1.01</b>
5" x 20	<b>141-1002</b>	<b>1.68</b>	<b>1.51</b>	<b>1.34</b>
6" x 20	<b>141-1007</b>	<b>1.79</b>	<b>1.61</b>	<b>1.43</b>
7" x 20	<b>141-1009</b>	<b>2.19</b>	<b>1.97</b>	<b>1.75</b>

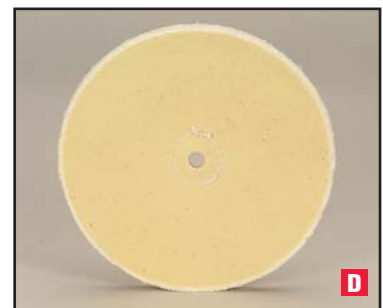

**E Plum Muslin Buffs – With Leather Centers**

Made of chemically treated fine-weave muslin with combed edge and leather centers. Impart an amazing finish on soft metals. Last much longer than yellow and white buffs, cut fast and provide an ultra-high polish when used with yellow glow or rouge. Retain compound extremely well. Thread count: 86/80.

Dia. x Ply	Rows of Stitching	Item#	EACH Prices		
			1-11	12-35	36+
4" x 40	3	<b>140-6660</b>	<b>\$3.45</b>	<b>\$3.11</b>	<b>\$2.76</b>
5" x 45	3	<b>140-6661</b>	<b>4.57</b>	<b>4.11</b>	<b>3.66</b>
6" x 50	4	<b>140-6662</b>	<b>5.95</b>	<b>5.36</b>	<b>4.76</b>





## A Loose Plum Muslin Buffs – With Leather Centers

Made of the same chemically treated fine-weave muslin with combed edges and leather centers as our stitched plum muslin buffs, but with no sewing. Thread count: 86/80.

Dia. x Ply	Rows of Item#	EACH Prices		
		1-11	12-35	36+
4" x 40	<b>141-1020</b>	<b>\$3.02</b>	<b>\$2.72</b>	<b>\$2.42</b>
5" x 45	<b>141-1021</b>	<b>4.73</b>	<b>4.26</b>	<b>3.78</b>
6" x 50	<b>141-1022</b>	<b>5.59</b>	<b>5.03</b>	<b>4.47</b>



## B Loose Plum Muslin Buffs – 3/8" Arbor Hole

Made of the same chemically treated fine-weave muslin with combed edges as our stitched plum muslin buffs, but with no sewing. All have 3/8" diameter arbor holes for use on 3/8" arbor shaft. Not for use on tapered spindles. Thread count: 86/80.

Dia. x Ply	Rows of Item#	EACH Prices		
		1-11	12-35	36+
4" x 20	<b>141-1025</b>	<b>\$1.71</b>	<b>\$1.54</b>	<b>\$1.37</b>
5" x 20	<b>141-1030</b>	<b>1.95</b>	<b>1.76</b>	<b>1.56</b>
6" x 20	<b>141-1035</b>	<b>2.39</b>	<b>2.15</b>	<b>1.91</b>



## C Razor-Edge White Muslin Buffs – With Leather Centers

Made of fine-weave muslin (except for #140-8650, which is coarse-weave). Excellent for reaching into areas where conventional buffs cannot, such as corners, channels and slots. Stitching provides a firm edge and maintains buff shape. Thread count: 86/80.

Dia.	Rows of Stitching	Item#	EACH Prices		
			1-11	12-35	36+
2 1/2"	5	<b>140-8250</b>	<b>\$1.51</b>	<b>\$1.36</b>	<b>\$1.21</b>
3"	5	<b>140-8300</b>	<b>1.84</b>	<b>1.66</b>	<b>1.47</b>
4"	5	<b>140-8400</b>	<b>2.15</b>	<b>1.94</b>	<b>1.72</b>
5"	9	<b>140-8500</b>	<b>3.57</b>	<b>3.21</b>	<b>2.86</b>
6"	11	<b>140-8600</b>	<b>3.81</b>	<b>3.43</b>	<b>3.05</b>
6"	11	<b>140-8650</b>	<b>3.47</b>	<b>3.12</b>	<b>2.78</b>



## D Razor-Edge Yellow Muslin Buffs – With Leather Centers

Made of chemically treated fine-weave muslin. Excellent for reaching into areas where conventional buffs cannot, such as corners, channels and slots. Stitching provides a firm edge and maintains buff shape. Thread count: 86/80.

Dia.	Rows of Stitching	Item#	EACH Prices		
			1-11	12-35	36+
5"	9	<b>141-8500</b>	<b>\$3.02</b>	<b>\$2.72</b>	<b>\$2.42</b>
6"	11	<b>141-8600</b>	<b>4.03</b>	<b>3.63</b>	<b>3.22</b>



## E Razor-Edge Plum Muslin Buff – With Leather Centers

Made of chemically treated fine-weave muslin. Excellent for reaching into areas where conventional buffs cannot, such as corners, channels and slots. Stitching provides a firm edge and maintains buff shape. Thread count: 86/80.

Dia.	Rows of Stitching	Item#	EACH Prices		
			1-11	12-35	36+
6"	11	<b>140-6670</b>	<b>\$4.49</b>	<b>\$4.04</b>	<b>\$3.59</b>

**A Chamois Buffs – With Leather Centers**

Made of soft, pliant leather for imparting a beautiful mirror finish.

Dia. x Thick	Rows of Stitching	Item#	Each
3" x 1/2"	2	<b>142-5300</b>	<b>\$6.93</b>
4" x 3/4"	3	<b>142-5400</b>	<b>14.44</b>
5" x 3/4"	3	<b>142-5500</b>	<b>24.05</b>
6" x 3/4"	4	<b>142-5600</b>	<b>31.50</b>



**B, C Faux Chamois Buffs – 3/8" Arbor Hole**

Economical yet long-lasting artificial chamois buffs that hold compound very well. Yellow perforated buffs can be used with more aggressive compounds such as tripoli and white diamond. Tan smooth buffs produce a wonderful luster when used with our finest rouges. See p. 127 for 4-Piece Intro Pack.

Dia. x Thick	Material	Use With	Item#	Each
<b>B.</b> 4" x 5/8"	Yellow perforated	Tripoli	<b>142-0004</b>	<b>\$6.20</b>
<b>C.</b> 4" x 1/2"	Tan smooth	Rouge	<b>142-0006</b>	<b>6.20</b>

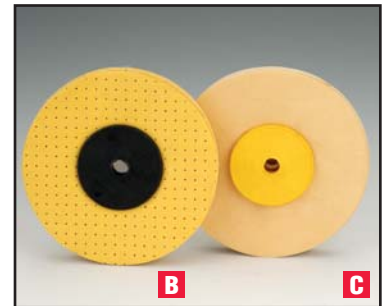

**D Felt Buffs – 100% Wool Felt with Leather Centers**

These buffs combine the excellent compound retention and longer life of a lap with the flexibility and contour-conforming pliability of a buff. Available in three hardnesses: soft is very flexible for following surface contours; medium is semiflexible and good for medium scratch removal; hard is stiff and perfect for deep scratch removal. Use on a tapered spindle.

Dia. x Ply	Hardness	Rows of Stitching	Item#	Each
6" x 6"	Soft	4	<b>283-0001</b>	<b>\$11.35</b>
6" x 6"	Medium	4	<b>283-0002</b>	<b>13.90</b>
6" x 6"	Hard	4	<b>283-0003</b>	<b>16.40</b>



**E Gesswein/Paramount™ Felt Laps**

Made by a unique process of steaming and pounding that eliminates the need for artificial hardeners and ensures good balance. Pinhole centers.

Dia. x Thick	Type	Item#	EACH Prices		
			1-5	6-11	12+
4" x 1/4"	Hard	<b>284-4145</b>	<b>\$12.15</b>	<b>\$10.94</b>	<b>\$10.12</b>
	Rock Hard	<b>284-4147</b>	<b>13.50</b>	<b>12.15</b>	<b>11.25</b>
4" x 1/2"	Soft	<b>284-4121</b>	<b>9.40</b>	<b>8.46</b>	<b>7.83</b>
	Medium	<b>284-4123</b>	<b>14.60</b>	<b>13.14</b>	<b>12.17</b>
	Hard	<b>284-4125</b>	<b>16.65</b>	<b>14.99</b>	<b>13.87</b>
	Rock Hard	<b>284-4127</b>	<b>18.20</b>	<b>16.38</b>	<b>15.17</b>
4" x 3/4"	Medium	<b>284-4343</b>	<b>20.39</b>	<b>18.35</b>	<b>16.99</b>
	Hard	<b>284-4345</b>	<b>22.12</b>	<b>19.91</b>	<b>18.43</b>
6" x 1/4"	Hard	<b>284-6145</b>	<b>23.00</b>	<b>20.70</b>	<b>19.17</b>
6" x 1/2"	Flint Hard	<b>284-6148</b>	<b>28.40</b>	<b>25.56</b>	<b>23.67</b>
	Soft	<b>284-6121</b>	<b>20.50</b>	<b>18.45</b>	<b>17.08</b>
	Medium	<b>284-6123</b>	<b>34.75</b>	<b>31.28</b>	<b>28.96</b>
	Hard	<b>284-6125</b>	<b>36.35</b>	<b>32.72</b>	<b>30.29</b>
	Rock Hard	<b>284-6127</b>	<b>38.50</b>	<b>34.65</b>	<b>32.08</b>
	Flint Hard	<b>284-6128</b>	<b>40.00</b>	<b>36.00</b>	<b>33.33</b>
	Hard	<b>284-6105</b>	<b>46.55</b>	<b>41.90</b>	<b>38.79</b>



**F Diamond Hard Felt Laps**

Chemically treated and pressed to extreme density for increased strength. Will not affect metal or leave it streaked. Can be shaped to knife or bevel edge.

Dia. x Thick x AH	Item#	EACH Prices		
		1-5	6-11	12+
4" x 1/4" x 1/4"	<b>284-4149</b>	<b>\$10.58</b>	<b>\$9.52</b>	<b>\$8.82</b>
4" x 1/2" x 1/4"	<b>284-4129</b>	<b>16.44</b>	<b>14.80</b>	<b>13.70</b>
6" x 1/4" x 1/4"	<b>284-6149</b>	<b>22.37</b>	<b>20.13</b>	<b>18.64</b>
6" x 1/4" x 1/2"	<b>284-6249</b>	<b>22.37</b>	<b>20.13</b>	<b>18.64</b>



## Felt Wheels

Manufactured from carefully selected wool without synthetic fibers or fillers, ensuring product reliability. Feature uniform density throughout for longer life. Yield high-quality finishes every time. Can be shaped.



### A Soft Felt Wheels – For High Finish

Can be used on irregular surfaces where fast metal removal is unnecessary. Pinhole centers. Mandrel not included (see p. 131 for mandrel selection).

Dia. x Thick	Item#	EACH Prices	
		12-132	144+
1" x 1/8"	<b>280-0005</b>	<b>\$.28</b>	<b>\$.23</b>
1 1/4" x 1/4"	<b>280-0006</b>	<b>1.00</b>	<b>.83</b>

*12-piece minimum; please order in multiples of 12.*



### B Hard Felt Wheels

Felts in this series have been cut from sheet stock, hardened to appropriate finishing requirements and dressed to size. Pinhole centers. Mandrel not included (see p. 131 for mandrel selection). Use 2" diameter and larger on tapered spindle.

Dia. x Thick	Item#	EACH Prices			
		1-2	3-11	12-143	144+
1/2" x 1/8"	<b>280-0020*</b>	–	–	<b>\$.32</b>	<b>\$.27</b>
5/8" x 1/8"	<b>280-0041*</b>	–	–	<b>.33</b>	<b>.27</b>
3/4" x 1/8"	<b>280-0060*</b>	–	–	<b>.36</b>	<b>.30</b>
1" x 1/8"	<b>280-0101*</b>	–	–	<b>.48</b>	<b>.40</b>
1" x 1/4"	<b>280-0110*</b>	–	–	<b>1.06</b>	<b>.88</b>
1 1/4" x 1/4"	<b>280-0120</b>	<b>\$1.64</b>	<b>\$1.48</b>	<b>1.37</b>	<b>1.15</b>
1 1/4" x 3/8"	<b>280-0130</b>	<b>1.75</b>	<b>1.58</b>	<b>1.46</b>	<b>1.23</b>
1 3/8" x 3/8"	<b>280-0140</b>	<b>1.97</b>	<b>1.77</b>	<b>1.64</b>	<b>1.38</b>
1 1/2" x 3/8"	<b>280-0160</b>	<b>2.15</b>	<b>1.94</b>	<b>1.79</b>	<b>1.51</b>
1 1/2" x 1/2"	<b>280-0170</b>	<b>3.40</b>	<b>3.06</b>	<b>2.83</b>	<b>2.38</b>
2" x 1/4"	<b>280-0200</b>	<b>2.30</b>	<b>2.07</b>	<b>1.92</b>	<b>1.61</b>
2" x 3/8"	<b>280-0210</b>	<b>2.86</b>	<b>2.57</b>	<b>2.38</b>	<b>2.00</b>
2" x 1/2"	<b>280-0220</b>	<b>4.42</b>	<b>3.98</b>	<b>3.68</b>	<b>3.09</b>
2 1/2" x 3/8"	<b>280-0260</b>	<b>4.13</b>	<b>3.72</b>	<b>3.44</b>	<b>2.89</b>

*\*12-piece minimum; please order in multiples of 12.*



### C Knife-Edge Felt Wheels

These felt wheels have tapered edges for polishing joints and crevices. Pinhole centers. Mandrel not included (see p. 131 for mandrel selection). Use 2" diameter and larger on tapered spindle.

Dia.	Type	Item#	EACH Prices		
			1-11	12-143	144+
1/2"	Hard	<b>281-0020*</b>	–	<b>\$.76</b>	<b>\$.63</b>
5/8"	Hard	<b>281-0040*</b>	–	<b>.87</b>	<b>.72</b>
3/4"	Hard	<b>281-0060*</b>	–	<b>.78</b>	<b>.65</b>
1"	Hard	<b>281-0100*</b>	–	<b>1.10</b>	<b>.92</b>
1 1/4"	Hard	<b>281-0200*</b>	–	<b>1.55</b>	<b>1.29</b>
1 1/2"	Hard	<b>281-0300*</b>	–	<b>1.30</b>	<b>1.08</b>
1 3/4"	Hard	<b>281-0400</b>	<b>\$2.99</b>	<b>2.49</b>	<b>2.09</b>
2"	Hard	<b>281-0501</b>	<b>3.95</b>	<b>3.29</b>	<b>2.77</b>
2 1/2"	Hard	<b>281-0700</b>	<b>5.10</b>	<b>4.25</b>	<b>3.57</b>
3"	Hard	<b>281-0800</b>	<b>5.54</b>	<b>4.62</b>	<b>3.88</b>
3"	Flint Hard	<b>281-1030</b>	<b>9.55</b>	<b>7.96</b>	<b>6.69</b>
4"	Flint Hard	<b>281-1040</b>	<b>22.40</b>	<b>18.67</b>	<b>15.68</b>

*\*12-piece minimum; please order in multiples of 12.*



**A, B Faux Chamois Buffs – 3/32" Shank**

Economical yet long-lasting artificial chamois buffs that hold compound very well. Yellow perforated buffs can be used with more aggressive compounds such as tripoli and white diamond. Tan smooth buffs produce a wonderful luster when used with our finest rouges. Mounted on 3/32" stainless steel shanks. Purchase money-saving four-piece intro pack to try both 1" buffs listed below and both 4" buffs listed on p. 125.

Dia. x Thick	Color/Material	Use With	Item#	EACH Prices	
				1-11	12+
<b>A.</b> 1" x 3/8"	Yellow/Perforated	Tripoli	<b>142-0020</b>	<b>\$.99</b>	<b>\$.89</b>
<b>B.</b> 1" x 3/16"	Tan/Smooth	Rouge	<b>142-0024</b>	<b>.99</b>	<b>.89</b>
4-Piece Intro Pack (two 1" and two 4" buffs)			<b>142-0015</b>	<b>12.95</b>	<b>-</b>

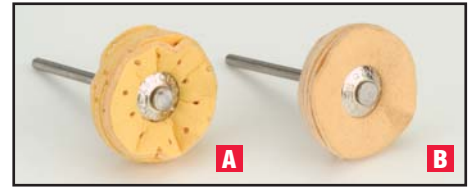

**C, D Mounted Muslin Buffs – 3/32" Shank**

Available in firm yellow for cutting and soft white for polishing. Mounted on 3/32" shank stainless steel mandrels.

Dia. x Thick	Color	Item#	EACH Prices	
			1-11	12+
<b>C.</b> 1" x 3/16"	Yellow	<b>142-0330</b>	<b>\$.89</b>	<b>\$.80</b>
<b>D.</b>	White	<b>142-0335</b>	<b>.78</b>	<b>.70</b>

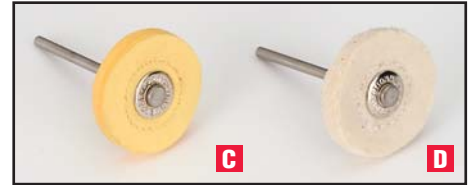

**E - I Mandrel Buffs – For use with rotary handpieces.**

Made of stitched fine-weave muslin with shellac pinhole centers. Mandrel not included (see p. 131 for mandrel selection). Thread count: 80/80.

Dia. x Ply	Rows of Stitching	Item#	EACH Prices	
			3-9	12+
<b>E.</b> 7/8" x 16	1	<b>142-0090</b>	<b>\$.87</b>	<b>\$.72</b>
<b>F.</b> 1" x 16	2	<b>142-0100</b>	<b>.90</b>	<b>.75</b>
<b>G.</b> 1 1/4" x 16	2	<b>142-0125</b>	<b>.92</b>	<b>.77</b>
<b>H.</b> 1 1/2" x 16	3	<b>142-0150</b>	<b>.95</b>	<b>.79</b>
<b>I.</b> 2" x 16	4	<b>142-0200</b>	<b>1.01</b>	<b>.84</b>

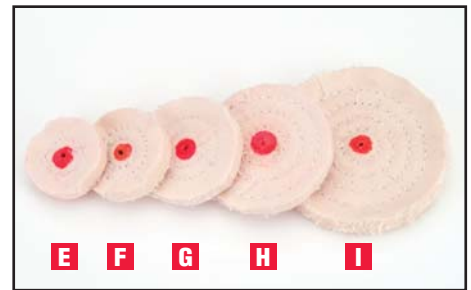

*Three-piece minimum; please order in multiples of three.*

**J Mounted Cotton String Buff – 3/32" Shank**

Made of individual soft cotton strings securely mounted on a 3/32" shank for use with a flex shaft handpiece. Good for accessing tight or recessed areas. Holds compound well.

Dia.	Item#	EACH Prices	
		1-11	12+
1"	<b>142-0300</b>	<b>\$1.47</b>	<b>\$1.22</b>



**K Mounted Loose Muslin Buff – 3/32" Shank**

Made of fine-weave muslin mounted on a 3/32" shank for use with a flex shaft handpiece. Ideal for accessing tight or recessed areas. Holds compound very well. Has long life span.

Dia. x Thick	Item#	EACH Prices	
		1-5	6+
7/8" x 1/4"	<b>142-0325</b>	<b>\$5.10</b>	<b>\$4.59</b>



**L Mounted Felt Wheel with Plastic Hub – 3/32" Shank**

Soft felt wheel mounted on a nonscratching plastic hub with 3/32" stainless steel shank. Works so well that it's patented. Use with compound for cutting and polishing.

Dia. x Thick	Item#	EACH Prices	
		1-11	12+
1" x 3/16"	<b>288-2209</b>	<b>\$.95</b>	<b>\$.86</b>



**M, N Synflex Polishers – 3/32" Shank**

Unique, patent-pending polishers for buffing and polishing in a single step. Made of soft synthetic material that conforms to just about any surface. Impregnated with abrasive to eliminate the need for messy polishing compounds. Mounted on 3/32" shanks.

Dia. x Ply	Micron	Item#	EACH Prices	
			1-35	36+
<b>M.</b> 7/8" x 3/8"	6	<b>284-1145</b>	<b>\$1.40</b>	<b>\$1.33</b>
<b>N.</b>	4	<b>284-1140</b>	<b>1.35</b>	<b>1.28</b>



# Polishing Supplies

## Felt Bobs

Made from the finest 100% wool for long life. Available mandrel-mounted or unmounted. May be used with various polishing compounds or rouges to produce a clean, high finish on molds, dies and models. Hard, medium and soft grades available in most shapes. All 1/8" shank unless otherwise indicated. All measurements in inches.

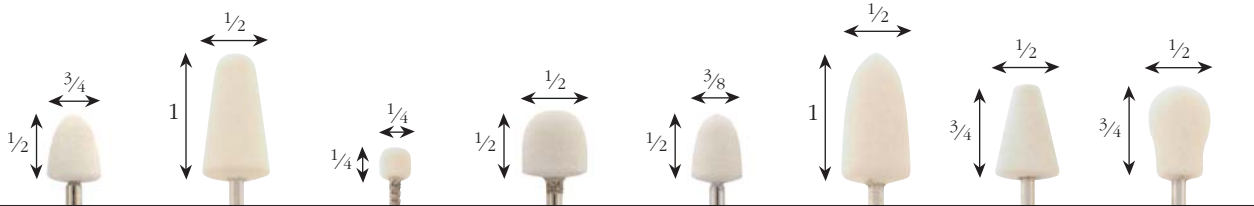

	Item#	Item#	Item#	Item#	Item#	Item#	Item#	Item#
Hard	<b>286-1010</b>	<b>286-1011</b>	<b>286-1020</b>	<b>286-1022</b>	<b>286-1030</b>	<b>286-1031</b>	<b>286-1040</b>	<b>286-1051</b>
Medium	<b>290-1010</b>	-	<b>290-1020</b>	<b>290-1022</b>	<b>290-1030</b>	-	-	-
Soft	<b>289-1010</b>	-	<b>289-1020</b>	<b>289-1022</b>	<b>289-1030</b>	-	-	-
Hard (3mm Shank)	<b>287-1010</b>	-	<b>287-1020</b>	-	-	-	-	-
12-24 (each)	<b>\$1.69</b>	<b>\$1.81</b>	<b>\$1.58</b>	<b>\$1.66</b>	<b>\$1.59</b>	<b>\$1.74</b>	<b>\$1.59</b>	<b>\$1.59</b>
36-60*	<b>1.61</b>	<b>1.72</b>	<b>1.50</b>	<b>1.58</b>	<b>1.51</b>	<b>1.65</b>	<b>1.51</b>	<b>1.51</b>
72+*	<b>1.52</b>	<b>1.63</b>	<b>1.42</b>	<b>1.49</b>	<b>1.43</b>	<b>1.57</b>	<b>1.43</b>	<b>1.43</b>

12-piece minimum; please order in multiples of 12.  
\*Quantity discount for orders of one item# only, not assorted.

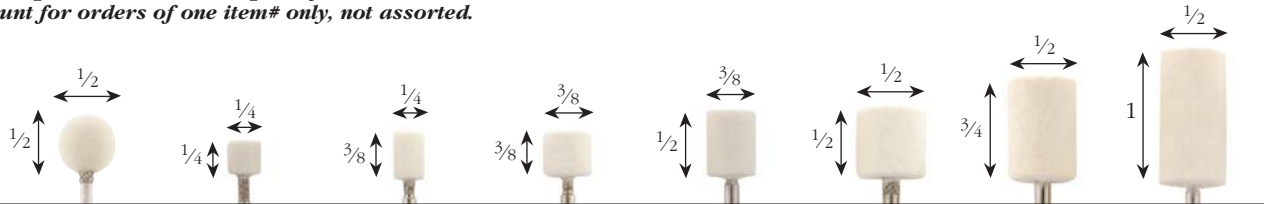

	Item#	Item#	Item#	Item#	Item#	Item#	Item#	Item#
Hard	<b>286-1060</b>	<b>286-1100</b>	<b>286-1101</b>	<b>286-1102</b>	<b>286-1103</b>	<b>286-1104</b>	<b>286-1105</b>	<b>286-1106</b>
Medium	-	<b>290-1100</b>	<b>290-1101</b>	<b>290-1102</b>	<b>290-1103</b>	<b>290-1104</b>	<b>290-1105</b>	<b>290-1106</b>
Soft	-	<b>289-1100</b>	<b>289-1101</b>	<b>289-1102</b>	<b>289-1103</b>	<b>289-1104</b>	<b>289-1105</b>	<b>289-1106</b>
Hard (3mm Shank)	-	<b>287-1100</b>	<b>287-1101</b>	<b>287-1102</b>	<b>287-1103</b>	<b>287-1104</b>	<b>287-1105</b>	-
12-24 (each)	<b>\$2.32</b>	<b>\$1.03</b>	<b>\$1.06</b>	<b>\$1.08</b>	<b>\$1.14</b>	<b>\$1.24</b>	<b>\$1.35</b>	<b>\$1.56</b>
36-60*	<b>2.20</b>	<b>.98</b>	<b>1.01</b>	<b>1.03</b>	<b>1.08</b>	<b>1.18</b>	<b>1.28</b>	<b>1.48</b>
72+*	<b>2.09</b>	<b>.93</b>	<b>.95</b>	<b>.97</b>	<b>1.03</b>	<b>1.12</b>	<b>1.22</b>	<b>1.40</b>

12-piece minimum; please order in multiples of 12.  
\*Quantity discount for orders of one item# only, not assorted.

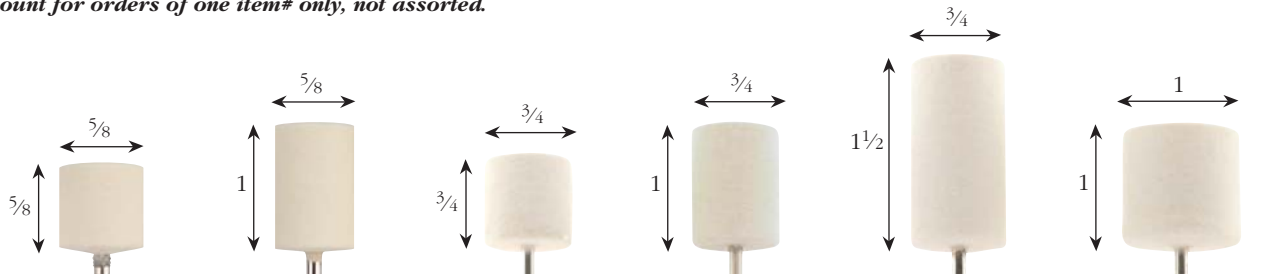

	Item#	Item#	Item#	Item#	Item#	Item#
Hard	<b>286-1107</b>	<b>286-1108</b>	<b>286-1110</b>	<b>286-1111</b>	<b>286-1113</b>	<b>286-1114</b>
Medium	<b>290-1107</b>	<b>290-1108</b>	<b>290-1110</b>	-	-	<b>290-1114</b>
Soft	<b>289-1107</b>	<b>289-1108</b>	<b>289-1110</b>	-	-	<b>289-1114</b>
Hard (3mm Shank)	-	-	<b>287-1110</b>	<b>287-1111</b>	-	<b>287-1114</b>
Hard (1/4" Shank)	<b>286-1097</b>	<b>286-1098</b>	<b>286-1099</b>	<b>286-1109</b>	<b>286-1112</b>	<b>286-1115</b>
12-24 (each)	<b>\$1.73</b>	<b>\$1.80</b>	<b>\$1.86</b>	<b>\$2.13</b>	<b>\$2.26</b>	<b>\$2.50</b>
36-60*	<b>1.64</b>	<b>1.71</b>	<b>1.77</b>	<b>2.02</b>	<b>2.15</b>	<b>2.38</b>
72+*	<b>1.56</b>	<b>1.62</b>	<b>1.67</b>	<b>1.92</b>	<b>2.03</b>	<b>2.25</b>

12-piece minimum; please order in multiples of 12.  
\*Quantity discount for orders of one item# only, not assorted.

**A Countersunk Felt Bob – 3mm Shank**

Wont “walk.” Polishes to the sidewall. Measures 7/8" dia. x 1"H with 3/8"D cavity and 3mm shank.

Hardness	Item#	EACH Prices	
		1-5	6+
Hard	<b>295-0010</b>	<b>\$5.10</b>	<b>\$4.85</b>
Rock Hard	<b>295-0012</b>	<b>5.10</b>	<b>4.85</b>
Diamond Hard	<b>295-0014</b>	<b>5.10</b>	<b>4.85</b>



**B - K Impregnated Felt Bobs – 1/8" Shank**

Felt bobs evenly impregnated with 8000 grit silicon carbide abrasive for uniform removal of light scratches and brightening. Help shorten the final finishing process. Reduce messy compound cleanup. Suitable for all metals, including soft metals such as brass. Available in hard and medium grades. Have 1/8" shanks. Max. operating speed: 15,000rpm.

Dia. x H	Hard Item#	Medium Item#	EACH Prices		
			1-35	36-71	72+
<b>B.</b> 3/8" x 1/2"	<b>284-1030</b>	<b>284-2000</b>	<b>\$2.40</b>	<b>\$2.28</b>	<b>\$2.16</b>
<b>C.</b> 1/4" x 1/4"	<b>284-1100</b>	<b>284-2002</b>	<b>1.54</b>	<b>1.46</b>	<b>1.39</b>
<b>D.</b> 1/4" x 3/8"	<b>284-1101</b>	–	<b>1.54</b>	<b>1.46</b>	<b>1.39</b>
<b>E.</b> 3/8" x 3/8"	<b>284-1102</b>	<b>284-2004</b>	<b>1.51</b>	<b>1.43</b>	<b>1.36</b>
<b>F.</b> 3/8" x 1/2"	<b>284-1103</b>	<b>284-2006</b>	<b>1.54</b>	<b>1.46</b>	<b>1.39</b>
<b>G.</b> 1/2" x 1/2"	<b>284-1104</b>	<b>284-2008</b>	<b>1.52</b>	<b>1.44</b>	<b>1.37</b>
<b>H.</b> 1/2" x 3/4"	<b>284-1105</b>	<b>284-2010</b>	<b>1.65</b>	<b>1.57</b>	<b>1.49</b>
<b>I.</b> 1/2" x 1"	<b>284-1106</b>	–	<b>2.38</b>	<b>2.26</b>	<b>2.14</b>
<b>J.</b> 3/4" x 3/4"	<b>284-1110</b>	<b>284-2012</b>	<b>2.79</b>	<b>2.65</b>	<b>2.51</b>
<b>K.</b> 1" x 1"	<b>284-1114</b>	<b>284-2014</b>	<b>3.49</b>	<b>3.32</b>	<b>3.14</b>

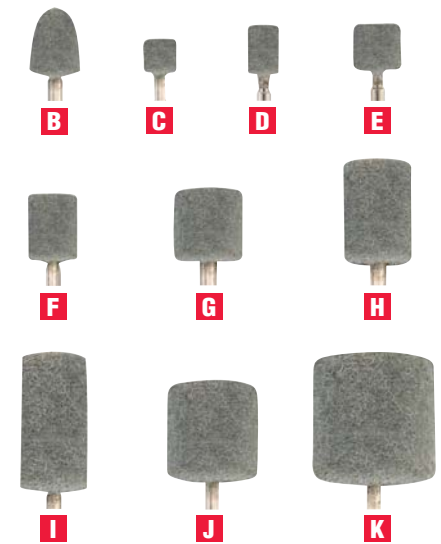

**L Hard Unmounted Felt Bobs**

Pinhole centers. Mandrel not included (see p. 131 for mandrel selection).

Dia. x H	Shape	Item#	EACH Prices	
			12-132	144+
1/4" x 3/8"	Cylinder	<b>288-0010</b>	<b>\$ .94</b>	<b>\$ .78</b>
3/8" x 1/2"	Cylinder	<b>288-0020</b>	<b>1.06</b>	<b>.88</b>
1/2" x 1/2"	Cylinder	<b>288-0030</b>	<b>1.20</b>	<b>1.00</b>
3/4" x 3/4"	Cylinder	<b>288-0040</b>	<b>1.54</b>	<b>1.28</b>
1" x 1"	Cylinder	<b>288-0050</b>	<b>2.65</b>	<b>2.21</b>

*12-piece minimum; please order in multiples of 12.*



**M Hard Unmounted Felt Cones**

Pinhole centers. Mandrel not included (see p. 131 for mandrel selection).

Dia. x H	Shape	Item#	EACH Prices		
			1-11	12-143	144+
1/4" x 1/2"	Pointed	<b>282-0480*</b>	–	<b>\$ .83</b>	<b>\$ .69</b>
3/8" x 3/4"	Pointed	<b>282-0490*</b>	–	<b>1.14</b>	<b>.95</b>
1/2" x 1"	Pointed	<b>282-0500*</b>	–	<b>1.56</b>	<b>1.30</b>
1/2" x 1"	Blunt	<b>282-0501*</b>	–	<b>1.56</b>	<b>1.30</b>
3/4" x 1 1/2"	Pointed	<b>282-0510</b>	<b>\$2.95</b>	<b>2.46</b>	<b>2.07</b>
3/4" x 1 1/2"	Blunt	<b>282-0511</b>	<b>2.97</b>	<b>2.47</b>	<b>2.08</b>
1" x 2"	Pointed	<b>282-0520</b>	<b>4.10</b>	<b>3.42</b>	<b>2.87</b>

*\*12-piece minimum; please order in multiples of 12.*



**N Hard Felt Shoulder Bobs**

These bobs are made of top-grade Spanish felt.

Dia.	Item#	EACH Prices	
		12-132	144+
1/2"	<b>288-2050</b>	<b>\$2.28</b>	<b>\$1.90</b>
3/4"	<b>288-2070</b>	<b>2.53</b>	<b>2.11</b>

*12-piece minimum; please order in multiples of 12.*



# Polishing Supplies

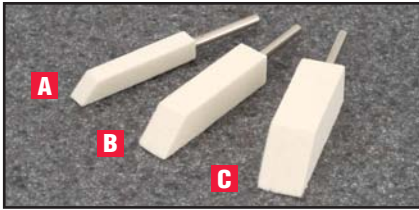

## A - C Hard Poli-Felts – 1/8" Shank

Feature end cut at 45° angle for comfort. For use with reciprocating handpieces such as Power Hand 2X SZX (see p. 90), Di-Profler (see p. 96) and others.

Dimensions	Style	Item#	EACH Prices		
			1-11	12-143	144+
A. 1/4" sq. x 1 1/2"L	61	<b>288-4610</b>	<b>\$3.25</b>	<b>\$2.71</b>	<b>\$2.28</b>
B. 3/8" sq. x 1 3/4"L	62	<b>288-4620</b>	<b>3.65</b>	<b>3.04</b>	<b>2.56</b>
C. 1/2" sq. x 1 3/4"L	63	<b>288-4630</b>	<b>3.95</b>	<b>3.29</b>	<b>2.77</b>



## D Felt Sticks

Made from the finest 100% wool, beveled at both ends. Use with polishing and finishing compounds to get into tight areas. Fits in double ender (see p. 20).

Dimensions	Type	Item#	Each
D. 1/4" sq. x 4"L	Hard	<b>288-3010</b>	<b>\$.64</b>
1/4" sq. x 4"L	Soft	<b>288-3020</b>	<b>.56</b>

*12-piece minimum; please order in multiples of 12.*



## E, F Soft Felt Hand Buffs

For high finish when used with rouge. Each has wooden handle with 6" of felt.

Dimensions	Item#	EACH Prices		
		1-11	12-143	144+
E. 7/8"W x 11 1/2"L	<b>288-1010</b>	<b>\$4.10</b>	<b>\$3.42</b>	<b>\$2.87</b>
F. 1/2"W x 11 1/2"L	<b>288-1015</b>	<b>3.09</b>	<b>2.57</b>	<b>2.16</b>



## G - I Specialty Buffs

Stitched muslin buffs for polishing inside tubular, tapered or concave surfaces and irregularly shaped areas.

Dia. x Length	Item#	EACH Prices	
		1-11	12+
G. 2" x 2"	<b>143-5200</b>	<b>\$15.45</b>	<b>\$12.87</b>
3" x 3"	<b>143-5300</b>	<b>20.15</b>	<b>16.79</b>
H. 2" x 2"	<b>143-1200</b>	<b>15.45</b>	<b>12.87</b>
3" x 3"	<b>143-1300</b>	<b>20.15</b>	<b>16.79</b>
3 1/2" x 3 1/2"	<b>143-1350</b>	<b>23.85</b>	<b>19.87</b>
I. 2" x 1 1/2"	<b>143-3200</b>	<b>11.29</b>	<b>9.41</b>
3" x 2"	<b>143-3300</b>	<b>13.58</b>	<b>11.32</b>
4" x 2 1/2"	<b>143-3400</b>	<b>19.50</b>	<b>16.25</b>



## J Cotton String Buff – 1/8" Arbor Hole

Made of tufts of individual soft cotton strings firmly anchored in a wooden hub for durability. Holds compound well and leaves a superb finish. For use on tapered spindle.

Dia. x Thick	Item#	Each
4" x 2"	<b>142-0001</b>	<b>\$9.19</b>



**Mandrels**

Use in handpieces and hand grinders for holding items such as felt wheels, brushes, rubberized abrasives, cut-off discs and more. Also see Cratex mandrels on p. 54.

**A - I Screw Mandrels**

For use with Pumice, Cratex and other wheels with a maximum thickness of 1/4". Right-handed threads. Made of steel except 321 1/2, which is stainless steel (excellent for wet operations).

Style	Shank	For Hole	Item#	EACH Prices		
				1-11	3-9	12+
A. 321	3/32"	1/16"	840-3170*	-	\$1.15	\$0.96
B. 321 1/2	3/32"	1/16"	840-3160*	-	2.30	1.92
C. 304	3/32"	1/16"	840-3175*	-	2.40	2.00
D. 2	3/32"	1/8"	840-3060*	-	1.95	1.62
E. 311	1/8"	1/16"	840-3150*	-	1.35	1.12
F. 20	1/8"	1/8"	840-3100*	-	2.05	1.71
G. 22	1/8"	1/8"	840-3110*	-	2.90	2.42
H. 24	1/8"	1/4"	840-3112*	-	2.20	1.83
I. 25	1/4"	1/4"	840-3115	\$4.30	-	3.58

\*Three-piece minimum; please order in multiples of three.



**J - O Tapered Thread Mandrels**

For use with felt bobs or cones. Right-handed threads.

Style	Shank	For Hole	Length of Taper	Item#	EACH Prices	
					3-9	12+
J. 3	3/32"	1/16"	3/16"	840-3070*	\$0.85	\$0.71
K. 0	3/32"	1/16"	3/8"	840-3040*	.85	.71
L. 13	1/8"	1/16"	3/16"	840-3090*	.85	.71
M. 30	1/8"	1/16"	3/8"	840-3120*	.85	.71

Style	Shank	For Hole	Length of Taper	Item#	EACH Prices	
					1-11	12+
N. 33	1/8"	1/4"	3/4"	840-3130	\$3.75	\$3.12
O. 43	1/4"	3/8"	1"	840-3140	6.80	5.67

\*Three-piece minimum; please order in multiples of three.



**P - S Threaded Mandrels with Nuts**

For use with rubberized points, cones, and cylinders such as Cratex. Right-handed threads.

Style	Shank	For Hole	Length of Thread	Item#	EACH Prices	
					3-9	12+
P. 1	3/32"	3/32"	1/2"	840-3050	\$1.20	\$1.00
Q. 4	1/8"	3/32"	1/2"	840-3080	1.15	.96
R. 6	1/8"	1/8"	1/2"	840-3085	3.85	3.21
S. 1341	1/4"	1/4"	1/2"	840-3180	5.75	4.79

Three-piece minimum; please order in multiples of three.



**Safety Recommendations**

Mandrels and mounted accessories improperly used are dangerous. Comply with American National Standards Institute Safety Code B7.1 and Occupational Safety and Health Act covering speed, safety guards, flanges, mounting procedures, general operating rules, handling, storage and inspection. Speeds to use depend on the accessory.

## Buffing Compounds

Buffing consists of two stages: cutting down and coloring. Cutting down is done to refine a surface by removing scratch lines, forming marks and other surface imperfections. It makes a relatively smooth surface smoother. Coloring merely refines the cut-down surface and brings out the maximum luster. Gesswein offers a complete line of top-quality compounds for all buffing needs. The same compound may produce different finishes on various materials; therefore, some experimentation may be necessary to determine which ones are preferable. Many polishing compounds contain respirable silica or other hazardous ingredients. Be sure to use a dust collector to pull polishing dust away from your breathing zone. For optimum protection, wear a properly fitted respirator rated for the specific dust or chemicals with which you are working.

**A**



**B**



**C**



**D**



**E**



**F**



**G**



**H**



**I**



**J**



**K**



**L**



Compound	Description and Application	Approx. Weight	Item#	EACH Prices	
				1-9	10+
<b>A. Grey Star</b>	Aggressive, dry compound removes deep scratches yet leaves a uniform finish. Excellent for brass and stainless steel.	1 lb.	<b>215-0915</b>	<b>\$3.85</b>	<b>\$3.08</b>
		2½ lbs.	<b>215-0910</b>	<b>8.85</b>	<b>7.08</b>
<b>B. Chrome</b>	Produces mirror finish on hard metals such as chrome, nickel steel and stainless steel. A medium cutting compound for soft metals.	2½ lbs.	<b>215-1550</b>	<b>8.50</b>	<b>6.80</b>
<b>C. Stainless</b>	For final finish on stainless steel. Provides light cutting action on soft metals. Contains a 240 grit steel compound but acts like a 320 or 400 grit compound because of binder.	2 lbs.	<b>215-0500</b>	<b>9.50</b>	<b>7.60</b>
<b>D. Bobbing</b>	For fast cutting on soft metals such as aluminum and brass. Yellow-tan in color. Compound sticks well to laps and brushes. Often used in place of Tripoli.	1 lb.	<b>215-1450</b>	<b>3.85</b>	<b>3.08</b>
<b>E. Tripoli</b>	Standard brown compound for cutting down and removing scratches from soft metals such as aluminum and brass. Leaves surface scratch-free but dull in appearance.	1 lb.	<b>215-0300</b>	<b>3.60</b>	<b>3.06</b>
<b>F. 4X White Diamond</b>	A medium cut-and-color compound for soft metals such as brass.	1 lb.	<b>215-1710</b>	<b>1.95</b>	<b>1.56</b>
<b>G. Hard White</b>	A medium cut-and-color compound for soft metals such as aluminum and brass.	1 lb.	<b>215-1700</b>	<b>4.95</b>	<b>3.96</b>
<b>H. Red Rouge</b>	Imparts extremely high luster on soft metals. The industry standard for producing the final finish. For brass and all nonferrous metals.	¼ lb.	<b>215-1050</b>	<b>1.75</b>	<b>1.40</b>
		½ lb.	<b>215-1100</b>	<b>3.50</b>	<b>2.80</b>
		1 lb.	<b>215-1150</b>	<b>6.50</b>	<b>5.20</b>
<b>I. Green Rouge</b>	Produces an extremely high luster on chrome and stainless steel.	¼ lb.	<b>215-0800</b>	<b>4.45</b>	<b>3.56</b>
<b>J. Yellow Glow</b>	For ultra-bright final finish. A premium quality rouge that works well on most metals. Has a very light cutting action yet leaves a high luster. Less greasy and cleaner to use than other rouges. The 12 oz. is a bar, and the 1 lb. is a peel-away container.	12 oz.	<b>215-0050</b>	<b>4.95</b>	<b>4.21</b>
		1 lb.	<b>215-0054</b>	<b>5.95</b>	<b>4.76</b>
<b>K. Lustre Bar</b>	Produces a very high luster on all metals as well as plastics. Removes light scratches yet leaves a bright mirror finish. Supplied in a peel-back cardboard tube.	1 lb.	<b>215-1600</b>	<b>5.95</b>	<b>4.76</b>
<b>L. C-Clear</b>	Restores plastic by removing scratches and blemishes.	6 oz.	<b>215-0041</b>	<b>5.45</b>	—

**A - F Water-Soluble Buffing Compounds**

A special emulsifier added to our Buffing Compounds provides cooler buffing and faster cleanup. There's no need for highly alkaline or acidic cleaning solutions—Water-Soluble Compounds rinse off your work easily with just soap and water.

Water-Soluble Compound	Description and Application	Approx. Weight	Item#	EACH Prices	
				1-9	10+
<b>A. Grey/Green</b>	For fast metal removal (more aggressive than Grey Star). For cutting white metals and brass.	2 lbs.	<b>215-1752</b>	<b>\$2.95</b>	<b>\$2.36</b>
<b>B. Grey Star</b>	Aggressive dry compound removes deep scratches yet leaves a uniform finish. For brass and stainless steel.	1 lb.	<b>215-1740</b>	<b>3.90</b>	<b>3.12</b>
<b>C. Tripoli</b>	Standard Tripoli in a water-soluble form. For cutting down and removing scratches from soft metals such as aluminum and brass. Leaves surface scratch-free and ready for final polish.	1 lb.	<b>215-1750</b>	<b>1.75</b>	<b>1.40</b>
<b>D. Yellow</b>	Produces a very high, final finish on white metals and brass.	2 lbs.	<b>215-1751</b>	<b>6.05</b>	<b>4.84</b>
<b>E. Green Rouge</b>	Produces an extremely high luster on chrome and stainless steel.	1 lb.	<b>215-1730</b>	<b>3.15</b>	<b>2.52</b>
<b>F. Red Rouge</b>	For the highest, brightest finish. Imparts a premium-grade finish on all soft metals.	¼ lb.	<b>215-1715</b>	<b>2.15</b>	<b>1.72</b>
		1 lb.	<b>215-1720</b>	<b>7.25</b>	<b>5.80</b>



**G Trial Set of Water-Soluble Compounds**

A money-saving set of four of our most popular Water-Soluble Compounds. Includes Grey Star for fast removal of deep scratches, Tripoli for cutting and removing scratches from aluminum and brass, Green Rouge for high luster on chrome and stainless steel, and our premium Red Rouge for an ultra-high finish on soft metals. Four 1 lb. bars.

Description	Item#	Each
4-Piece Trial Set	<b>215-1760</b>	<b>\$11.75</b>



**H Pumice Powder**

A natural abrasive used for cleaning surfaces and removing surface imperfections and firescale. Mix with water or oil and apply with a muslin buff to create a fine matte finish. Sold by the pound.

Description	Item#	POUND Prices	
		1-9	10+
Pumice Powder	<b>845-4000</b>	<b>\$2.50</b>	<b>\$2.13</b>



**I Abrasive Grain**

Accurately graded, pure abrasive grain can be blended with oil or grease to produce a custom-made lapping or polishing slurry. Sold by the pound.

Grit	Aluminum Oxide		Silicon Carbide	
	Item#	Each	Item#	Each
120	<b>218-1650</b>	<b>\$7.90</b>	<b>218-1700</b>	<b>\$6.04</b>
220	<b>218-1655</b>	<b>7.90</b>	<b>218-1705</b>	<b>6.04</b>
320	<b>218-1660</b>	<b>6.10</b>	<b>218-1710</b>	<b>7.90</b>
400	<b>218-1670</b>	<b>6.84</b>	<b>218-1715</b>	<b>8.95</b>
600	<b>218-1675</b>	<b>8.48</b>	<b>218-1720</b>	<b>13.35</b>
800	<b>218-1680</b>	<b>8.75</b>	<b>218-1725</b>	<b>15.80</b>



## A Very Soft Sticks

Made of select balsa wood with one shaped end. Use by hand, with reciprocating or rotary tools for final finishing with diamond and other compounds. Can be dressed with a knife or file. Measure 6" long.



Shape	Size	Item#	PKG. of 5	
			1-9	10+
Rectangular, beveled	1/8" x 1/8"	<b>825-0530</b>	<b>\$7.10</b>	<b>\$5.68</b>
	3/16" x 3/16"	<b>825-0532</b>	<b>8.55</b>	<b>6.84</b>
	1/8" x 1/4"	<b>825-0534</b>	<b>8.55</b>	<b>6.84</b>
	1/4" x 1/4"	<b>825-0536</b>	<b>8.25</b>	<b>6.60</b>

## B - D Soft Sticks

Made of select white birch with one shaped end. Use by hand, with reciprocating or rotary tools for intermediate to final finishing with diamond and other compounds. Measure 6" long.



Shape	Diameter	Item#	PKG. of 25	
			1-3	4+
B. Round, pointed	1/8"	<b>825-0551</b>	<b>\$8.75</b>	<b>\$6.56</b>
	1/4"	<b>825-0557</b>	<b>9.95</b>	<b>7.46</b>
C. Round, double-beveled	1/8"	<b>825-0541</b>	<b>8.75</b>	<b>6.56</b>
	1/4"	<b>825-0547</b>	<b>9.95</b>	<b>7.46</b>

Shape	Size	Item#	PKG. of 5	
			1-9	10+
D. Rectangular, beveled	1/8" x 1/8"	<b>825-0501</b>	<b>\$5.35</b>	<b>\$4.28</b>
	3/16" x 3/16"	<b>825-0503</b>	<b>5.35</b>	<b>4.28</b>
	1/8" x 1/4"	<b>825-0505</b>	<b>5.95</b>	<b>4.76</b>
	1/4" x 1/4"	<b>825-0507</b>	<b>6.95</b>	<b>5.56</b>

## E Pegwood Sticks

Flexible multipurpose sticks that maintain a fine point and resist breaking when pushed into a hole. Use by hand, with reciprocating or rotary tools for intermediate finishing with diamond and other compounds. Dress with a knife or file. Measure 6" long.



Shape	Diameter	Item#	BUNDLE of 24	
			1-9	10+
Round	2mm	<b>825-1201</b>	<b>\$8.85</b>	<b>\$7.52</b>
	2.5mm	<b>825-1202</b>	<b>8.85</b>	<b>7.52</b>
	3mm	<b>825-1203</b>	<b>8.85</b>	<b>7.52</b>
	4mm	<b>825-1204</b>	<b>8.85</b>	<b>7.52</b>

## F - H Rockwood Sticks

Very hard, laminated sticks that retain their shape well. Use by hand, with reciprocating or rotary tools for initial finishing with diamond and other compounds. Can be dressed with a knife or file. Measure 6" long with blunt ends (except #825-0005, which has one pointed end, and #825-0045, which has one beveled end). Dark brown in color.



Shape	Size	Item#	EACH Prices	
			1-11	12+
F. Round	1/8"	<b>825-0005</b>	<b>\$3.10</b>	<b>\$2.58</b>
	3/16"	<b>825-0010*</b>	<b>4.55</b>	<b>3.79</b>
	1/4"	<b>825-0020*</b>	<b>5.59</b>	<b>4.66</b>
	3/8"	<b>825-0030</b>	<b>9.15</b>	<b>7.62</b>
	1/2"	<b>825-0040*</b>	<b>12.95</b>	<b>10.79</b>
G. Square	1/8"	<b>825-0045</b>	<b>2.88</b>	<b>2.40</b>
	1/4"	<b>825-0060</b>	<b>4.55</b>	<b>3.79</b>
H. Rectangular	1/8" x 1/4"	<b>825-0050*</b>	<b>3.65</b>	<b>3.04</b>
	1/4" x 3/8"	<b>825-0070*</b>	<b>5.45</b>	<b>4.54</b>
	1/4" x 1/2"	<b>825-0080*</b>	<b>6.15</b>	<b>5.12</b>
	5/16" x 1"	<b>825-0110</b>	<b>10.25</b>	<b>8.54</b>
Set 1R, 18 pieces (three of each asterisked number)		<b>825-0300</b>	<b>49.50</b>	—
Set 2R, 27 pieces (three of each size except 1/8" square and round)		<b>825-0400</b>	<b>75.80</b>	—



**A Wood Bobs – 1/8" Shank**

Natural wood bobs for intermediate finishing with rotary tools. Can be shaped for contours. Use dark-colored hard bobs with 15 micron or coarser diamond compounds, light-colored soft bobs with 15 micron or finer. Sold in packages of 10 or in a 12-piece set.

Description	Size	Hard Item#	Soft Item#	Pkg. of 10
Ball	3/8" dia.	<b>825-0618</b>	<b>825-0638</b>	<b>\$32.99</b>
Cylinder	1/4" dia. x 5/8"L	<b>825-0605</b>	<b>825-0625</b>	<b>31.95</b>
	3/8" dia. x 3/4"L	<b>825-0607</b>	<b>825-0627</b>	<b>34.99</b>
Flame	3/8" dia. x 5/8"L	<b>825-0610</b>	<b>825-0630</b>	<b>32.99</b>
	3/8" dia. x 1 1/4"L	<b>825-0612</b>	<b>825-0632</b>	<b>34.99</b>
	1/2" dia. x 3/4"L	<b>825-0614</b>	<b>825-0634</b>	<b>34.99</b>
Description		Item#		Each
A. 12-Piece Set (one of each)		<b>825-0640</b>		<b>\$34.99</b>



**A**

**B Brilliant Luster Cream – For a high polish without the harsh odor.**

Produces a lustrous mirror sheen on mold and die surfaces. Quickly removes stains and oxidation, as well as the haze created by diamond polishing. Can be used on all steels, aluminum, chrome, brass and bronze. Goes on and comes off easily with a felt bob, soft cloth or tissue paper. Emits no harsh odors, unlike other brands. Nonhazardous and noncorrosive.

Description	Item#	Each
50g Jar	<b>218-2220</b>	<b>\$6.95</b>
250g Jar	<b>218-2230</b>	<b>21.95</b>
1,000g Jar	<b>218-2235</b>	<b>59.95</b>
50g Jars, box of 24	<b>218-2225</b>	<b>139.95</b>



**B**

**C Simichrome Polish®**

One of the finest all-metal polishes in the world. Produces an ultra-high finish. Ideal for chrome, steel, brass, gold, silver and more. Use with a felt bob or soft cloth to impart a brilliant luster. Leaves a protective film. Recommended for use after diamond compound.

Description	Item#	Each
50g Tube	<b>218-2050</b>	<b>\$9.95</b>
250g Tin	<b>218-2150</b>	<b>29.95</b>
1,000g Tin	<b>218-2200</b>	<b>72.95</b>
50g Tubes, box of 24	<b>218-2100</b>	<b>183.95</b>



**C**

**D Tetrabor® Compound**

Boron carbide compound. Great for refining surface finishes and cutting without heat buildup. Best for use on carbide and hardened steel. Packaged in 100-gram tubes.

Grit	Item#	Each
60	<b>218-1005</b>	<b>\$41.35</b>
100	<b>218-1010</b>	<b>41.35</b>
220	<b>218-1050</b>	<b>41.35</b>
320	<b>218-1080</b>	<b>47.45</b>
400	<b>218-1090</b>	<b>47.45</b>
600	<b>218-1100</b>	<b>54.75</b>
800	<b>218-1110</b>	<b>54.75</b>
1200	<b>218-1130</b>	<b>63.30</b>



**D**

**E Clover® Lapping Compound**

Grease-based silicon carbide compound. Great for refining surface finishes and cutting without heat buildup. Most economical for tight areas where compound loss is excessive. Best for use on 50HRC and softer steels. Packaged in 1 lb. cans.

Grit	Item#	Each
180	<b>218-3180</b>	<b>\$23.95</b>
220	<b>218-3220</b>	<b>23.95</b>
320	<b>218-3320</b>	<b>25.95</b>
400	<b>218-3400</b>	<b>25.95</b>
600	<b>218-3600</b>	<b>39.75</b>
1000	<b>218-3610</b>	<b>39.75</b>
1200	<b>218-3620</b>	<b>55.95</b>



**E**



**A**

**A Baldor® Polishing Motor #29-1 – 1/2 HP, 3,450rpm**

Fully enclosed, double-spindle heavy-duty motor for buffs up to 8" diameter. Prelubricated ball bearings for long life. Motor has 5/8" diameter straight shafts and is supplied with two tapered spindles. Overall height: 11 1/2". Shaft height: 8 1/8". Ship. Wt. 51 lbs. Made in USA.

Electrical	Base (W x D)	Width to end of spindles	Item#	Each
115V, 1 Ph, 50/60Hz	8" x 8 1/2"	29"	<b>854-1250</b>	<b>\$430.00</b>

*220V, 50/60Hz available. 50Hz speed is 3,000rpm.*



**B**

**B Sealed Polishing Motor #15 – 1/2 HP, 3,450rpm**

Double-spindle, sealed motor with 5/8" shafts (shaft height: 5"). Two tapered spindles supplied. Ship. Wt. 29 lbs. Imported.

Electrical	Item#	Each
110V, 50/60Hz	<b>854-1265</b>	<b>\$250.00</b>



**C**

**C Standard Polishing Motor #12 – 1/2 HP, 3,450rpm**

Double-spindle motor with 5/8" shafts (shaft height: 3"). Two tapered spindles supplied. Ship. Wt. 18 lbs. Made in USA.

Electrical	Item#	Each
110V, 50/60Hz	<b>854-1260</b>	<b>\$167.00</b>



**D**

**D - G Arbors**

Used to mount polishing and buffing wheels with 1/2" arbor holes onto polishing or lapping motors.

Style/Motor Shaft	For Wheel Thickness	Overall Length	Item#	Each
<b>D.</b> For 29-1 Right 5/8" *	1 1/2"	7"	<b>840-4668</b>	<b>\$29.00</b>
<b>E.</b> For 29-1 Left 5/8"	1 1/2"	6"	<b>840-4660</b>	<b>29.00</b>
<b>F.</b> For 26-1 Right 1/2"	1/2"-1"	4 1/4"	<b>840-4550</b>	<b>18.00</b>
<b>G.</b> For 26-1 Left 1/2"	1/2"-1"	4 1/4"	<b>840-4500</b>	<b>18.00</b>

*\*With extended tapered spindle for cloth buffs.*



**E**



**F**



**G**



**H**

**H Arbor with Bur Chuck**

For right side of motor only. Has set screws for 1/2" straight shafts. The three-jaw keyless chuck holds up to 1/4" shanks. Measures 4" long.

Description	Item#	Each
Arbor with Bur Chuck	<b>840-4150</b>	<b>\$29.00</b>

**A Finger Guard Safety Tape**

Offers ideal protection wherever gloves are awkward. Use for buffing, grinding, benchwork and more. Protects hands, fingers and wrists from sharp edges, hot surfaces and abrasive materials. Made of pure surgical-grade gauze coated with natural latex rubber. Sticks only to itself, not to hair, skin or clothing. Fast and easy to apply, painless to remove. Conforms to smallest contours while open mesh lets skin breathe. Will not stain or leave residue. Individual roll contains 90' of 3/4" wide tape. Color: green.

Description	Item#	Each
Individual Roll	<b>816-0203</b>	<b>\$2.25</b>
Package of 16 Rolls	<b>816-0202</b>	<b>28.00</b>



**B 3M® Vetrap Bandage Tape**

Maintain your sense of touch with this comfortable and cool tape. Easy to use, stays in place on fingers. Each roll contains 15' of 2" wide tape. Available in five colors.

Description	Item#	EACH Prices	
		1-4	5+
Blue	<b>816-0214</b>	<b>\$1.75</b>	<b>\$1.64</b>
Green	<b>816-0215</b>	<b>1.75</b>	<b>1.64</b>
Pink	<b>816-0216</b>	<b>1.75</b>	<b>1.64</b>
Red	<b>816-0217</b>	<b>1.75</b>	<b>1.64</b>
White	<b>816-0218</b>	<b>1.75</b>	<b>1.64</b>



**C Suede Finger Guards**

Thick suede offers greatest protection from abrasives and heat. Elastic cloth back allows for comfortable fit. Open-ended.

Description	Item#	EACH Prices	
		10-90	100+
Suede	<b>816-0200</b>	<b>\$ .78</b>	<b>\$ .70</b>

*Ten-piece minimum; please order in multiples of 10.*



**D Leather Finger Cots**

Protect fingers during grinding operations. Made of soft leather for a comfortable fit.

Description	Dimensions (L x W)	Item#	EACH Prices		Item#	Box of 1,000
			10-90	100+		
Small/Med. Cots	2 1/4" x 1"	<b>816-0205*</b>	<b>\$ .79</b>	<b>\$ .71</b>	<b>816-0206</b>	<b>\$615.00</b>
Med./Large Cots	3" x 1 1/2"	<b>816-0190*</b>	<b>2.80</b>	<b>2.52</b>	<b>816-0195</b>	<b>2,187.50</b>
Large Thumb Cots**	2 1/2" x 2"	<b>816-0186*</b>	<b>1.69</b>	<b>1.52</b>	<b>816-0187</b>	<b>1,312.50</b>
Elastic-Back Cots	2 3/4" x 1 3/4"	<b>816-0188*</b>	<b>2.78</b>	<b>2.50</b>	<b>816-0189</b>	<b>2,625.00</b>

*\*Ten-piece minimum; please order in multiples of 10.*



**E - H Rubber Finger Guards**

Superior quality with sure grip, ventilated for comfort. Protect fingers during finishing and handling. Have extra-long life.

Description	Style	Item#	DOZEN Prices	
			1-11	12+
<b>E. Small</b>	11	<b>816-0220</b>	<b>\$4.70</b>	<b>\$3.76</b>
<b>F. Medium</b>	12	<b>816-0225</b>	<b>4.70</b>	<b>3.76</b>
<b>G. Large</b>	13	<b>816-0230</b>	<b>4.70</b>	<b>3.76</b>
<b>H. X-Large</b>	14	<b>816-0235</b>	<b>4.70</b>	<b>3.76</b>

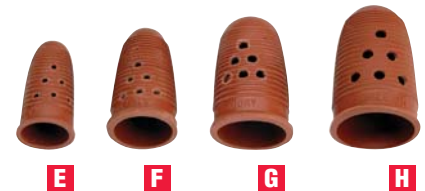

**I Cotton Knit Finger Guards**

Provide excellent protection from heat, burns and abrasion during grinding and finishing operations. Made of 100% soft cotton yarn. Lack of side seams provides better feel.

Description	Item#	EACH Prices		Item#	Box of 1,000
		10-90	100+		
Small	<b>816-0207*</b>	<b>\$.48</b>	<b>\$.43</b>	<b>816-0208</b>	<b>\$399.00</b>
Large	<b>816-0211*</b>	<b>.48</b>	<b>.43</b>	<b>816-0212</b>	<b>399.00</b>

*\*Ten-piece minimum; please order in multiples of 10.*



**A Torit® VS Dust Collectors**

Torit VS Dust Collectors feature a state-of-the-art filter cartridge that offers ultra-high efficiency air cleaning and collects precious metal particles less than 1 micron in size. The two-part filter consists of an outer fabric screen that captures coarse and fibrous particles on the surface. This outer screen has a leakproof velcro closure that makes it easy to remove and clean (can be vacuumed and washed). Outer screen also prolongs the surface life of the inner filter cartridge. High-frequency vibration cleans the filter cartridge automatically every time the Dust Collector is shut off.

These dust collectors do not need to be vented to the outside, saving you money on heating and cooling costs. Constructed of 16-gauge steel. Blower chamber is acoustically treated to minimize noise. Hinged doors provide easy access to filter chamber. There are four inlet knockouts located on back, top and sides for convenient positioning of ductwork.

<b>Specifications:</b>	<b>VS-550</b>	<b>VS-1200</b>	<b>VS-1500</b>
Dim. (L x W x H)*	24" x 30 <sup>3</sup> / <sub>4</sub> " x 52 <sup>3</sup> / <sub>16</sub> "	24" x 30 <sup>3</sup> / <sub>4</sub> " x 62 <sup>3</sup> / <sub>16</sub> "	24" x 30 <sup>3</sup> / <sub>4</sub> " x 68 <sup>3</sup> / <sub>16</sub> "
Number of Stations	2-3	4-6	6-8
CFM	550	1,243	1,525
Horsepower	1	3	5
dBA (decibels)	69	74	79
Filter Area (sq. ft.)	65	135	177
Inlet Diameter	4"	6"	7"
Dust Drawer Capacity	1.8 cu. ft.	1.8 cu. ft.	1.8 cu. ft.
Net/Ship. Wt. (lbs.)	295/350	320/370	335/385

*\*Allow an additional 12" in height for exhaust clearance.*

Model	Electrical	Item#	Each
<b>A. VS-550</b>	208/230/460V, 3 Ph, 60Hz	<b>854-1430</b>	<b>\$3,697.00</b>
VS-1200	208/230/460V, 3 Ph, 60Hz	<b>854-1435</b>	<b>4,840.00</b>
VS-1200 w/drawer	115/230V, 1 Ph, 60Hz	<b>854-1436</b>	<b>5,200.00</b>
VS-1500	208/230/460V, 3 Ph, 60Hz	<b>854-1440</b>	<b>5,661.00</b>
Replacement VS-550 Filter	–	854-1414	\$298.35
Replacement VS-1200 Filter	–	854-1416	391.50
Replacement VS-1500 Filter	–	854-1453	440.00



**A**



**B**



**C**

**B, C Torit® Model 84 Cabinet Dust Collector**

This model features the efficient, compact design for which Torit is famous. Because of its high dust collection efficiency (99.9% by weight), this Dust Collector does not need to be vented to the outside. That means interior air is recirculated, saving you money on heating and cooling costs. Built-in silencer minimizes noise.

Replacing filter bags has never been easier than with the one-piece EZ Filter Pack. The entire filter bag system can be replaced at once with no tools! Cotton sateen bags are attached to a compact lightweight frame that you simply unfold and snap into place. Manually operated filter shaker makes cleaning easy. Collected dust settles into pullout dust drawer. There are four inlet knockouts located on back, top and sides for convenient positioning of ductwork.

**Specifications:**

Dim. (L x W x H)*	28 <sup>1</sup> / <sub>2</sub> " x 29 <sup>1</sup> / <sub>2</sub> " x 48"	No. of Filter Bags	30
Number of Stations	4-6	Filter Area (sq. ft.)	150
CFM	1,231	Inlet Diameter**	6-7"
Horsepower	3	Dust Drawer Capacity	2 cu. ft.
dBA (decibels)	73	Ship. Wt. (lbs.)	365

*\*Allow an additional 12" in height for exhaust clearance.*

*\*\*Please specify duct and hose diameter.*

Model	Electrical	Item#	Each
<b>B. Model 84</b>	208/230/460V, 3 Ph, 60Hz	<b>854-1455</b>	<b>\$3,253.00</b>
<b>C. Replacement EZ Filter Pack</b>	–	854-1458	683.00



**A, B Polisher/Dust Collector #75-0**

Provides high suction and advanced filtration to collect more precious metal and improve air quality at the same time. Includes dust collector, choice of polishing motors, durable benchtop and hoods. Made in USA.

**Features:**

- Dust Collector #77 with high-power suction motor, set of 24 cloth filter bags for recovering particles as small as half a micron in size and combination of foot-operated bag shaker and removable dust drawer for easy cleanup
- Custom-made Formica benchtop with mahogany trim, which can be predrilled to accommodate polishing motors and flex hoses at no extra charge
- Choice of heavy-duty polishing motors (see below)
- Two lighted, tapered hoods for good visibility and suction (light-bulbs not included)
- Extra 3" inlet for nearby workstations
- Flex hoses and clamps

**Specifications:**

**Suction Motor**

Electrical 110V, 1 Ph, 60Hz  
 Power 3/4 HP for producing 600 CFM suction

Airflow 600 CFM (300 CFM for each hood during simultaneous operation)

Filter Area 62 sq. ft.

**Dimensions**

Overall 4' or 5'W x 28"D x 56"H  
 Cabinet 22"W x 20"D x 40"H  
 Benchtop 4' or 5'W x 28"D

Polishing Motors	Benchtop Width	Ship Wt. (lbs.)	Item#	Each
None	4'	293	<b>854-2007</b>	<b>\$1,838.00</b>
None	5'	305	<b>854-2010</b>	<b>1,874.00</b>
Two #75XR, 220V*	5'	394	<b>854-2005</b>	<b>2,282.00</b>
Two #50R, 110V	4'	371	<b>854-1995</b>	<b>2,693.00</b>
<b>A.</b> Two #50R, 110V	5'	383	<b>854-2000</b>	<b>2,577.00</b>
#50R & #50L, 110V	5'	383	<b>854-2002</b>	<b>2,577.00</b>
<b>B.</b> 29-1R/L, 110V	4'	344	<b>854-2012</b>	<b>2,228.00</b>
29-1R/L, 110V	5'	356	<b>854-2015</b>	<b>2,264.00</b>
Description			Item#	Each
4' Undrilled Table			<b>854-2020</b>	<b>\$235.50</b>
5' Undrilled Table			<b>854-2021</b>	<b>252.50</b>
Replacement Filter Bags, set of 24			854-3145	485.00

\*Polishing motor plug not supplied.

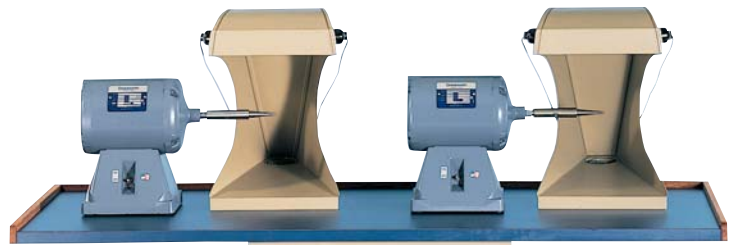

**Important Safety Tips For Polishing**

- Buffs should be securely twisted onto the tapered spindle before turning the motor on. Be sure to keep the buff centered and straight for true running. With the tapered spindle correctly installed, the turning force of the motor will keep the buff safely and securely mounted during grinding or polishing.
- Always grind or polish on the lower quarter of the buff in order to control the action and to prevent the work from being pulled out of your grip. Never intertwine your fingers with the workpiece. Hold the workpiece in a manner that will prevent your fingers from being harmed should it be pulled from your grip.
- Any grinding operation will remove small amounts of metal from the workpiece. To protect your eyes from flying debris, you should always wear safety goggles or similar eye protection.
- Be sure to tie back loose hair and clothing securely to prevent entanglement in the polishing motor or spindle.



## A Model 90-D Dust Collector

A full-size unit with high suction and two additional 3" outlets that can provide suction for two nearby workstations. The large aluminum tabletop and the overhead rack offer ample room for work-in-progress and storage. Large aluminum hoods have plastic safety shields and light fixtures (bulbs not included). Comes with three Dacron filters. Ample knee room for sit-down operation. Total suction of 1,000 CFM is created by two turbine fans driven by a 1/2 HP suction motor.

### Specifications:

Electrical	110V, 6A, 60Hz
Filter Area	Three 12" x 32" x 2" Dacron filters, 2,304 cu. in. total volume
Work Surface Area	48"W x 24"D
Work Surface Height	38"
Overall Height	59"
Cabinet	34 <sup>3</sup> / <sub>4</sub> "W x 16"D
Ship. Wt.	232 lbs.

Model	Item#	Each
90-D Dust Collector only	<b>854-1310</b>	<b>\$1,789.00</b>
90-D with 1/2 HP #29-1 motor	<b>854-1320</b>	<b>2,179.00</b>
PAIR Prices		
Replacement Part	Dimensions	Item#
Dacron Filter (pair)	12" x 32" x 2"	854-3410
		\$27.90
		\$25.11

See p. 136 for motor specifications.



## B Dust Collector Model #60B

**Comes complete with built-in silencer.**

This compact unit (only 23<sup>1</sup>/<sub>2</sub>" high) fits neatly under the workbench and out of the way, providing ample leg room without using precious bench space.

### Specifications:

Suction Motor	1/2 HP
Electrical	110V, 9A, 1 Ph, 60Hz
Filter	14 cloth bags, 6 <sup>1</sup> / <sub>4</sub> " x 12", totaling 14 sq. ft.
Filter Shakedown	External foot pedal, removable catch pan
Inlets	Two 3" dia. inlets located in back
Dimensions	15"W x 15 <sup>1</sup> / <sub>8</sub> "D x 23 <sup>1</sup> / <sub>2</sub> "H
Ship. Wt.	80 lbs.

Description	Item#	Each
#60B Dust Collector	<b>854-1370</b>	<b>\$685.00</b>
Replacement Filter Bag Set	854-3152	239.00



## C Flexible Hose, Clamp and Duct Tape

Connect your dust collecting equipment with our heavy-duty reinforced 3" diameter hose (sold by the foot). Specially designed low-profile ribs maximize suction. Secure with clamps and duct tape (2" wide, 60 yard long roll).

Description	Item#	Each
Hose, 1'	<b>854-3050</b>	<b>\$7.40</b>
Clamp	<b>854-3060</b>	<b>4.25</b>
Tape	<b>854-3119</b>	<b>7.25</b>



## D 3M™ Performance Plus Duct Tape

Removes cleanly with no sticky residue, unlike conventional duct tape. Designed for permanent and temporary applications indoors and out. Ideal for taping joints in dust collector pipes and hoses. Features waterproof backing with high tensile strength for resisting sunlight, moisture, wear and abrasion. Tears width and lengthwise without curling to make application much easier. Tack-free edges keep roll clean and help minimize waste. Writable surface allows marking for identification purposes. Slate blue. Sold in 1.8"W x 180' rolls.

Description	Item#	Each
Performance Plus Duct Tape	<b>854-3132</b>	<b>\$6.15</b>

**A Model 762 Benchtop Dust Collector**

Our Model 762 contains a 1/3 HP suction motor with squirrel-cage turbine that creates 465 CFM. Large, easily replaced Dacron filter traps metals. Available without a polishing motor or complete with either a #12 polishing motor or a #15 sealed polishing motor and spindles. See p. 136 for polishing motor specifications.

The hinged front tilts up to allow polishing of larger pieces. The 1/2" lip is perfect for storage of buffs, compounds and more. Accommodates buffs up to 6" in diameter. Designed for light buffing and polishing only, not for grinding. Built-in lights provide excellent visibility (60W bulbs not included). On/off switch operates both dust collector and polishing motor. Made in USA of top-quality 18-gauge sheet steel. Can be shipped via UPS.



**A**

**Specifications:**

Suction Motor 1/3 HP, 110V, 50/60Hz (also available in 220V)  
 Filter Area Heavy-duty 690 cu. in. filter  
 Dimensions 32 1/8"W x 12 1/8"H x 21 3/4"D

Model	Ship. Wt.	Item#	Each
762 Dust Collector only	62 lbs.	<b>854-1551</b>	<b>\$355.00</b>
762 with #12 motor	80 lbs.	<b>854-1550</b>	<b>484.00</b>
762 with #15 sealed motor	91 lbs.	<b>854-1555</b>	<b>625.00</b>

Replacement Part	Dimensions	Item#	PAIR Prices	
			1-9	10+
Dacron Filter (pair)	12" x 32" x 2"	854-3410	\$27.90	\$25.11

**B - D Foredom® Bench Motor – 1/6 HP; 1,800–7,000rpm**

The high-torque permanent-magnet BL-1A Bench Motor provides plenty of power for grinding and polishing. Features variable speed control, permanently lubricated ball bearings, sealed motor housing, heavy-duty cast-iron base with four mounting holes and power indicator light. Includes two tapered spindles for buffs up to 4" in diameter; threaded right wheel mandrel for rubber grinding wheels up to 2" in diameter and right collet holder with 3/32" and 1/4" collets. Motor height: 5 1/8". Shaft height: 3 3/4". Shaft diameter: 5/16". Ship. wt: 9 1/4 lbs. Polishing Hood collects metal and polishing dust to keep your shop clean. Measures 4 3/4"W x 8"D x 6 3/8"H. Includes 2" connection pipe for most standard shop-vacs. Jacobs Chuck Arbor allows easy mounting of tools with shanks from 1/16" to 1/4". Includes chuck key.

Electrical	Base (W x D)	Width to end of spindles	Item#	Each
<b>B.</b> 110V, 2A, 50/60Hz	6" x 5"	13"	<b>850-0619</b>	<b>\$185.00</b>
<b>C.</b> Optional Polishing Hood			<b>850-0626</b>	<b>49.00</b>
<b>D.</b> Optional Jacobs Chuck Arbor			<b>850-0629</b>	<b>45.00</b>
Optional Left Wheel Mandrel			<b>850-0613</b>	<b>14.00</b>
Optional 1/8" Collet for Right Collet Holder			<b>850-5430</b>	<b>7.00</b>
Replacement Right Collet Holder with 3/32" Collet			850-0623	20.00
Replacement Right Collet Holder with 1/4" Collet			850-0624	29.00
Replacement Right Wheel Mandrel			850-0621	14.00
Replacement 3/32" Collet for Right Collet Holder			850-5420	7.00

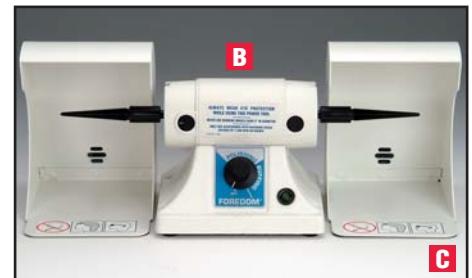

**C**



**D**

**E Foredom® Flexade®**

**Converts your bench motor into a flexible shaft machine!**

Works with the right side of a bench motor (see Foredom BL-1A above), drill press, electric drill or similar power source that takes a 5/16" shank and operates between 1,500 and 14,000rpm (run at 3,500rpm or more for best performance). Has a 1/4" ball bearing coupling at the motor drive end. Attaches to a drill or similar power tool with a length of 1/4" drill rod. Compatible with all flexible shaft handpieces except 25H, 30H and 44HT (see pp. 104–105 for handpieces).

Description	Item#	Each
Foredom Flexade	<b>850-0622</b>	<b>\$24.95</b>



**E**

**A Quatro SolderPure Fume and Particulate Extractor**

Features a four-stage filtration system that returns clean air to your workplace, making outside ventilation unnecessary. Includes capture hood with flex arm for 360° positioning, table bracket and 8' flex hose for remote location, casters for good mobility and fused on/off controls. Installs quickly and easily. Airflow: 125 CFM. Noise level: 52 dBA. Electrical: 120V, 1A, 60Hz. Measures 13"W x 16"D x 20"H. Weighs 47 lbs. Backed by a two-year manufacturer's warranty.

**Filtration System Features:**

- Prefilter – Captures the biggest particles, prolonging the life of subsequent filters. Inexpensive and easy to change.
- HiCap Filter – Provides high-capacity particle retention.
- HEPA Filter – Picks up 99.97% of 0.3 micron particulate, including soot and pollen. Recirculates clean air back into the room to help minimize heating and AC costs.
- Advanced Media Filter – Captures specific fumes.



**A**

Description	Item#	Each
<b>A.</b> SolderPure for Rhodium, Electrocleaner and Soldering Fumes	<b>854-1375</b>	<b>\$1,325.00</b>
SolderPure for Rhodium and Electrocleaner Fumes	<b>854-1387</b>	<b>1,246.00</b>
SolderPure for Soldering and Wax Fumes	<b>854-1376</b>	<b>1,195.00</b>

**B Quatro Ductless Fume Hoods**

Ideal for shops without access to outside ductwork. Feature a two-stage filtration system that captures fumes, then recirculates clean air back into the room to save on heating and AC costs. Burnout fume hood installs right on wall behind burnout furnace. Rhodium fume hood installs directly over plating area. Each has a metal-frame filter container that holds an activated charcoal media mixture specifically formulated for the respective application. Electrical: 120V, 1.6A, 60Hz. Measures 28"W x 18"D x 26"H. Weighs 50 lbs. Backed by a two-year manufacturer's warranty. Media refills available (each contains enough mixture for four refills).



**B**

Description	Item#	Each
<b>B.</b> Burnout Fume Hood	<b>854-1525</b>	<b>\$1,130.00</b>
Rhodium Fume Hood	<b>854-1526</b>	<b>1,130.00</b>
Media Refill for Burnout Filter	<b>854-1527</b>	<b>207.00</b>
Media Refill for Rhodium Filter	<b>854-1396</b>	<b>145.00</b>

**C Air Cleaning System #250**

This portable three-stage system efficiently filters welding and soldering fumes, as well as smoke and dust from grinding ceramic, rubber, plastic and graphite. Requires no outside ventilation or additional ductwork. Features HEPA filter for capturing 99.97% of 0.3 micron particulate, then returns absolutely clean air to your workplace. Comes complete with collector box, three prefilters, HEPA filter (installed), round suction hood with base, 10' of duct hose (allows use of up to 30' with minimal power loss) and two hose clamps. Airflow: 250 CFM. Noise level: 80 dBA. Electrical: 115V, 14A, 60Hz (230V available). Measures 13"W x 13"D x 12"H. Ship. wt: 30 lbs.



**C**

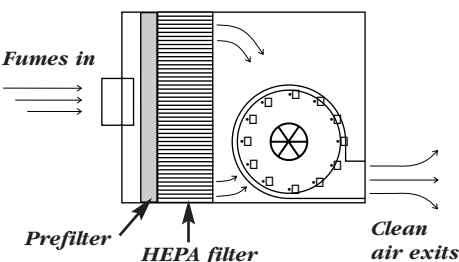

Description	Item#	Each
<b>C.</b> Air Cleaner System #250	<b>831-2000</b>	<b>\$845.00</b>
Y-Adapter (for two stations; requires Hood-and-Hose Assembly)	<b>831-2015</b>	<b>60.00</b>
Hood-and-Hose Assembly	<b>831-2025</b>	<b>95.00</b>
Charcoal Filter	<b>831-2002</b>	<b>35.00</b>
Replacement H.E.P.A. Filter	831-2010	120.00
Replacement Prefilters, set of three	831-2005	8.00



**A - C Quatro Fresh-Air Series HEPA Air Purifiers**

Polishing operations create a great deal of dust, some harmless and some toxic. Many dust collectors pick up much of the dust at the source, but polishing operations also allow a substantial amount of dust to become airborne and settle around the shop. Quatro HEPA Air Purifiers capture airborne dust and other contaminants before they settle in an advanced three-stage filtration system, then recirculate clean air back into the room. All units provide complete room air exchange approx. 15 times per hour. Each has smooth-rolling casters for hassle-free relocation to dustiest areas. Easy to install: just plug into any 120V outlet. Optional odor filter available by special order.

**Filtration System Features:**

- Prefilter – Captures the biggest particles, prolonging the life of subsequent filters. Inexpensive and easy to change.
- HiCap Filter – Provides high-capacity particle retention.
- HEPA Filter – Picks up 99.97% of 0.3 micron particulate, including soot and pollen. Recirculates clean air back into the room to help minimize heating and AC costs.

Model	Dimensions (W x D x H)	Max. Room Size (Sq. Feet)*	Draw (Amps)	Item#	Each
400	13" x 16" x 28½"	250	0.6	<b>854-1523</b>	<b>\$920.00</b>
<b>A.</b> 600	22" x 16" x 37"	400	1.0	<b>845-1522</b>	<b>1,640.00</b>
<b>B.</b> 1000	22" x 16" x 52"	600	1.6	<b>845-1521</b>	<b>2,000.00</b>
<b>C.</b> 2000	24" x 26" x 71"	1,200	5.4	<b>845-1520</b>	<b>3,135.00</b>

\*Based on 8' ceiling.



**D Quatro AirStream**

Perfect for small shops because it mounts on the wall instead of taking up precious floor space. Features an advanced filtration system that captures airborne dust, odors and other contaminants down to 0.3 microns. Recirculates clean air back into the room. Provides 100% air exchange approx. 15 times per hour. Suitable for rooms up to 200 sq. ft. in size (based on 8' ceiling). Includes easy-to-use electronic controls and filter replacement alert. Electrical: 120V, 1.0A, 60Hz. Measures 16¾"W x 9¾"D x 23½"H. Weighs 43 lbs.

**Filtration System Features:**

- Dust/Odor Filter – Advanced fine-grade dust filter impregnated with activated carbon.
- HEPA Filter – Picks up 99.97% of 0.3 micron particulate, including soot and pollen. Recirculates clean air back into the room to help minimize heating and AC costs.

Description	Item#	Each
<b>D.</b> Quatro AirStream	<b>854-2099</b>	<b>\$895.00</b>
Replacement Dust/Odor Filter	<b>854-2098</b>	<b>40.00</b>
Replacement HEPA Filter	<b>854-1397</b>	<b>117.00</b>



**E Quatro Jet-Stream Under-Bench Dust Collector**

This compact dust collector removes at least 99.97% of particulate, pollen, mold and even bacteria from the air. Uses whisper-quiet high-speed turbine motor with variable speed control to provide light to heavy suction. Ideal for small shops. Includes preinstalled HEPA and antimicrobial filters, two heavy-duty 4'L x 1½" dia. hoses, two adapters and dual inlet connection for collecting dust from two stations at once. Can be situated on the floor under or next to your bench or attached to your bench with the optional bench mounting plate. Electrical: 120V, 7A, 60Hz (230V, 4A, 50Hz available). Measures 14¼"W x 10⅛"D x 12⅛"H. Weighs 28 lbs.

Description	Item#	Each
<b>E.</b> Jet-Stream	<b>854-1500</b>	<b>\$699.00</b>
Optional Bench Mounting Plate	<b>854-1510</b>	<b>59.00</b>
Replacement HEPA Filter	<b>854-1512</b>	<b>49.00</b>
Replacement Antimicrobial Filters, pkg. of 5	<b>854-1505</b>	<b>39.00</b>



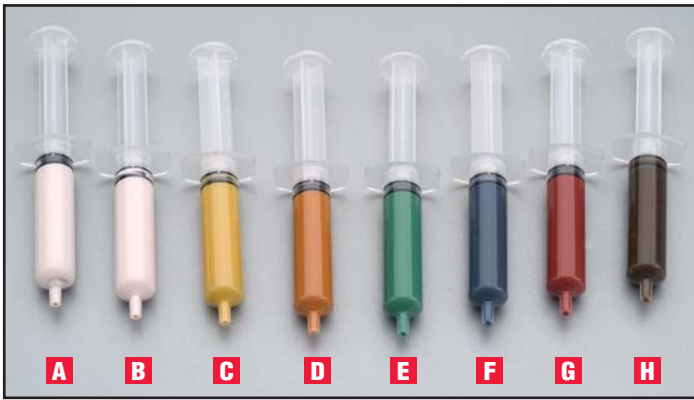

## A - H Gesswein® Diamond Compounds

Feature evenly distributed 100% virgin synthetic diamond, more consistent in shape than natural diamond, for fast, consistent cutting action. All grades can be special-ordered in L (light, 50%), M (medium, 75%) and H (heavy, 100%) concentrations. Standard Oil-Soluble Compounds hold together very well, even under high-speed conditions. Specifically formulated for the mold and die industry. Can be thinned with Oil-Soluble Lubricant/Thinner (see p. 145). Water-Soluble compounds have the same concentrations as Oil-Soluble Compounds. Allow fast and easy cleanup. Can be thinned with Water-Soluble Lubricant/Thinner (see p. 145). Consider Budget Oil-Soluble Compounds when affordability is a factor (lower prices are due to variations in particle size and friability). Packaged in 1-gram, 6-gram and 18-gram disposable syringes.

Grade	Application	Approx. Micron	Mesh	Color	Syringe Size (grams)	Standard Oil-Soluble Item#	Water-Soluble Item#	Each	Budget Oil-Soluble Item#	Each
A. 1/2-9M	Supreme finish	0-1	60000	White	1	<b>216-0045</b>	-	<b>\$2.95</b>	-	-
					6	<b>216-2045</b>	-	<b>12.00</b>	-	-
					18	<b>216-7055</b>	-	<b>26.00</b>	-	-
B. 1-8M	Super finish	0-2	14000	Ivory	1	<b>216-0050</b>	<b>216-9052</b>	<b>2.25</b>	-	-
					6	<b>216-2050</b>	<b>216-9064</b>	<b>10.00</b>	<b>216-9100</b>	<b>\$8.00</b>
					18	<b>216-7055</b>	<b>216-9076</b>	<b>26.00</b>	<b>216-9112</b>	<b>20.80</b>
C. 3-7M	Very high finish	2-4	8000	Yellow	1	<b>216-0100</b>	<b>216-9054</b>	<b>3.75</b>	-	-
					6	<b>216-2100</b>	<b>216-9066</b>	<b>19.50</b>	<b>216-9102</b>	<b>15.60</b>
					18	<b>216-7105</b>	<b>216-9078</b>	<b>54.00</b>	<b>216-9114</b>	<b>43.20</b>
D. 6-48M	Mirror finish	4-8	3000	Orange	1	<b>216-0150</b>	<b>216-9056</b>	<b>4.95</b>	-	-
					6	<b>216-2150</b>	<b>216-9068</b>	<b>26.50</b>	<b>216-9104</b>	<b>21.20</b>
					18	<b>216-7155</b>	<b>216-9080</b>	<b>75.00</b>	<b>216-9115</b>	<b>60.00</b>
E. 9-6M	High finish	8-12	1800	Green	1	<b>216-0200</b>	<b>216-9058</b>	<b>4.95</b>	-	-
					6	<b>216-2200</b>	<b>216-9070</b>	<b>26.50</b>	<b>216-9106</b>	<b>21.20</b>
					18	<b>216-7205</b>	<b>216-9082</b>	<b>75.00</b>	<b>216-9116</b>	<b>60.00</b>
F. 15-5M	Fine finish	12-22	1200	Blue	1	<b>216-0250</b>	<b>216-9060</b>	<b>4.95</b>	-	-
					6	<b>216-2250</b>	<b>216-9072</b>	<b>26.50</b>	<b>216-9108</b>	<b>21.20</b>
					18	<b>216-7255</b>	<b>216-9084</b>	<b>75.00</b>	<b>216-9118</b>	<b>60.00</b>
G. 30-4H	Fast lapping	22-36	600	Red	1	<b>216-0300</b>	<b>216-9062</b>	<b>7.25</b>	-	-
					6	<b>216-2300</b>	<b>216-9074</b>	<b>41.50</b>	<b>216-9110</b>	<b>33.20</b>
					18	<b>216-7305</b>	<b>216-9086</b>	<b>120.00</b>	<b>216-9120</b>	<b>96.00</b>
H. 45-3H	Medium cutting	36-54	325	Brown	1	<b>216-0350</b>	-	<b>7.25</b>	-	-
					6	<b>216-2350</b>	-	<b>41.50</b>	-	-
					18	<b>216-7355</b>	-	<b>120.00</b>	-	-
60-2H	Fast cutting	-	230	Purple	1	<b>216-0400</b>	-	<b>7.25</b>	-	-
					6	<b>216-2400</b>	-	<b>41.50</b>	-	-
					18	<b>216-7405</b>	-	<b>120.00</b>	-	-
90-1H	Coarse cutting	-	170	Gray	1	<b>216-0450</b>	-	<b>7.25</b>	-	-
					6	<b>216-2450</b>	-	<b>41.50</b>	-	-
					18	<b>216-7455</b>	-	<b>120.00</b>	-	-
120H	Fast grinding	-	120	Black	1	<b>216-0500</b>	-	<b>7.25</b>	-	-
					6	<b>216-2500</b>	-	<b>41.50</b>	-	-
					18	<b>216-7505</b>	-	<b>120.00</b>	-	-



## I Gesswein® Diamond Compound Sets

Convenient sets give you a wide range of grits for lapping and polishing applications. Oil-Soluble Set contains 1-gram syringes of 3-7M, 9-6M, 30-4H and 60-2H and a 3/4 oz. bottle of Lubricant/Thinner (see p. 145). Water-Soluble Set contains 1-gram syringes of 3-7M, 9-6M, 15-5M and 30-4H and a 3/4 oz. bottle of Lubricant/Thinner (see p. 145).

Description	Item#	Each
Oil-Soluble Set	<b>216-9500</b>	<b>\$22.35</b>
I. Water-Soluble Set	<b>216-9200</b>	<b>20.45</b>

**A SUPRA® Diamond Compounds**

Oil-soluble compounds with very heavy concentration of 100% virgin synthetic diamond for sharp, even cutting action. Graded to closer tolerances than those dictated by nationally recognized standards. Provide much faster stock removal than traditional diamond compounds. Sold in 5-gram Precision Applikators, which afford finer control than ordinary syringes.

Grade	End Use	Approx. Micron	Mesh	Color	Item#	Each
1-S	Super finish	0-2	14000	Ivory	<b>217-0010</b>	<b>\$11.70</b>
3-S	Very high finish	2-4	8000	Yellow	<b>217-0015</b>	<b>19.50</b>
6-S	Mirror finish	4-8	3000	Orange	<b>217-0020</b>	<b>22.10</b>
9-S	High finish	6-12	1800	Green	<b>217-0025</b>	<b>23.40</b>
15-S	Fine finish	10-20	1200	Blue	<b>217-0030</b>	<b>23.40</b>
30-S	Fast lapping	20-40	600	Red	<b>217-0035</b>	<b>31.20</b>



**B SUPRA® Diamond Compounds for Aluminum**

Oil-soluble compounds with extra-heavy concentration of 100% virgin synthetic diamond for sharp, even cutting action on aluminum. Graded to closer tolerances than those dictated by nationally recognized standards. Provide much faster stock removal than traditional diamond compounds. Formulated not to break down under heat or pressure. Sold in 5-gram Precision Applikators, which afford finer control than ordinary syringes.

Grade	End Use	Approx. Micron	Mesh	Color	Item#	Each
1-S	Super finish	0-2	14000	Ivory	<b>217-0100</b>	<b>\$9.50</b>
3-S	Very high finish	2-4	8000	Yellow	<b>217-0105</b>	<b>16.95</b>
6-S	Mirror finish	4-8	3000	Orange	<b>217-0110</b>	<b>19.50</b>
9-S	High finish	6-12	1800	Green	<b>217-0120</b>	<b>20.85</b>
15-S	Fine finish	10-20	1200	Blue	<b>217-0125</b>	<b>20.85</b>
30-S	Fast lapping	20-40	600	Red	<b>217-0130</b>	<b>28.75</b>



**C - G Lubricant/Thinner and Spray Bottle**

To use Diamond Compounds most efficiently, we recommend adding a lubricant to allow the compound to cut at its peak performance and to prevent the felt bob from gumming up or chattering. When added to Diamond Compound on the workpiece, lubricant thins out the mixture, creating a slurry and extending the compound. Available in spray or squeeze bottle for moistening felts prior to diamond compound application. Fill empty 4 oz. spray bottle with cleaning solution, lubricants and more for easy dispensing. Spray gets into hard-to-reach areas.

Description	Size	Item#	Each
<b>C.</b> Oil-Soluble Lubricant/Thinner	¾ oz. Squeeze Bottle	<b>825-1295</b>	<b>\$2.50</b>
<b>D.</b>	4 oz. Spray Bottle	<b>825-1303</b>	<b>4.95</b>
<b>E.</b>	8 oz. Bottle	<b>825-1300</b>	<b>6.85</b>
<b>F.</b>	32 oz. Bottle	<b>825-1305</b>	<b>19.60</b>
Water-Soluble Lubricant/Thinner	¾ oz. Squeeze Bottle	<b>825-1290</b>	<b>1.95</b>
	4 oz. Spray Bottle	<b>825-1310</b>	<b>4.80</b>
	8 oz. Bottle	<b>825-1315</b>	<b>6.50</b>
	32 oz. Bottle	<b>825-1320</b>	<b>19.60</b>
Description		Item#	Each
<b>G.</b> Empty 4 oz. Spray Bottle		<b>811-2460</b>	<b>\$2.15</b>



## Gesswein® Diamond Files

Premium diamond files for use on steels, carbides, ceramics, plastics and more. Features 100% synthetic diamonds—more consistent in shape than natural diamonds—plated onto high-strength steel blanks for consistent cutting and long life. See p. 211 for file handles.



### A - F Gesswein® Diamond Needle Files

Diamond needle files with 3mm round handles. Measure 5½" long. Plated ends measure 2¾" long. Can be used alone or with needle file handles (see p. 211).

Style	Shape	Grit	Item#	EACH Prices		
				1-4	5-9	10+
A. Round		150	<b>240-2162</b>	<b>\$22.00</b>	<b>\$20.90</b>	<b>\$19.80</b>
B. Half-Round		150	<b>240-2152</b>	<b>22.00</b>	<b>20.90</b>	<b>19.80</b>
C. Square		150	<b>240-2142</b>	<b>22.00</b>	<b>20.90</b>	<b>19.80</b>
D. Three-Square		150	<b>240-2132</b>	<b>22.00</b>	<b>20.90</b>	<b>19.80</b>
E. Equalling		150	<b>240-2112</b>	<b>22.00</b>	<b>20.90</b>	<b>19.80</b>
F. Barrette		150	<b>240-2102</b>	<b>22.00</b>	<b>20.90</b>	<b>19.80</b>
6-Piece Set (one of each)			<b>240-2200</b>	<b>125.00</b>	-	-

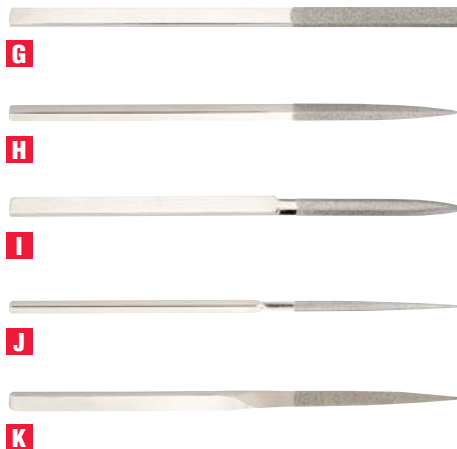

### G - K Gesswein® Diamond Hand Files

Heavy-duty diamond hand files with square shanks for use by hand or with handles. Measure 215mm (8½") long. Plated ends measure a generous 80mm (3⅝") long.

Style	Shape	W x Thick	Grit	Item#	Each
G. Equalling		11.0 x 3.5mm	100	<b>241-0746</b>	<b>\$39.95</b>
			200	<b>241-0747</b>	<b>39.95</b>
			400	<b>241-0748</b>	<b>39.95</b>
H. Square		6.3 x 6.3mm	100	<b>241-0735</b>	<b>39.95</b>
			200	<b>241-0736</b>	<b>39.95</b>
			400	<b>241-0737</b>	<b>39.95</b>
I. Half-Round		10.5 x 4.4mm	100	<b>241-0749</b>	<b>39.95</b>
			200	<b>241-0730</b>	<b>39.95</b>
			400	<b>241-0731</b>	<b>39.95</b>
J. Round		5.0mm	100	<b>241-0732</b>	<b>39.95</b>
			200	<b>241-0733</b>	<b>39.95</b>
			400	<b>241-0734</b>	<b>39.95</b>
K. Three-Square		7.7mm	100	<b>241-0738</b>	<b>39.95</b>
			200	<b>241-0739</b>	<b>39.95</b>
			400	<b>241-0740</b>	<b>39.95</b>
5-Piece Set (one of each style)			100	<b>241-0741</b>	<b>169.95</b>
			200	<b>241-0742</b>	<b>169.95</b>
			400	<b>241-0743</b>	<b>169.95</b>



### L - O Gesswein® Tapered Diamond Hand Files

Tapered diamond hand files with slim handles for sure grip. Measure 180mm (7") long. Plated ends measure 40mm long on 2mm wide files, 50mm long on all others.

Style	Shape	W x Thick	Grit	Item#	Each
L. Flat		2 x 1.5-0.4mm	150	<b>241-0801</b>	<b>\$22.00</b>
			200	<b>241-0802</b>	<b>22.00</b>
			400	<b>241-0803</b>	<b>22.00</b>
M.		4 x 2.0-0.5mm	150	<b>241-0804</b>	<b>22.00</b>
			200	<b>241-0805</b>	<b>22.00</b>
			400	<b>241-0806</b>	<b>22.00</b>
N.		6 x 2.0-0.5mm	150	<b>241-0807</b>	<b>22.00</b>
			200	<b>241-0808</b>	<b>22.00</b>
			400	<b>241-0809</b>	<b>22.00</b>
O.		8 x 2.5-0.5mm	150	<b>241-0810</b>	<b>22.00</b>
			200	<b>241-0811</b>	<b>22.00</b>
			400	<b>241-0812</b>	<b>22.00</b>
12-Piece Set (one of each)				<b>241-0800</b>	<b>250.00</b>



**A - E Gesswein® Diamond Rifflers**

Curved, double-ended diamond files with square handles. Measure 6" long. Plated ends measure 1" long.

Style	Shape	Grit	Item#	EACH Prices		
				1-4	5-9	10+
A. 16R		150	<b>240-3165</b>	<b>\$25.00</b>	<b>\$23.75</b>	<b>\$22.50</b>
B. 18R		150	<b>240-3180</b>	<b>25.00</b>	<b>23.75</b>	<b>22.50</b>
C. 22R		150	<b>240-3222</b>	<b>25.00</b>	<b>23.75</b>	<b>22.50</b>
D. 24R		150	<b>240-3225</b>	<b>25.00</b>	<b>23.75</b>	<b>22.50</b>
E. 26R		150	<b>240-3230</b>	<b>25.00</b>	<b>23.75</b>	<b>22.50</b>
5-Piece Set (one of each)			<b>240-3250</b>	<b>115.00</b>	-	-



**F - R Gesswein® Diamond Poli Files**

Parallel diamond machine files for use in reciprocating handpieces (see pp. 90, 109 and 113). All have 3mm shanks. Measure approx. 2" long. Plated ends measure 5/8" long.

Style	Shape	W x Thick	Grit	Item#	Each
F. Flat		2 x 1mm	150	<b>240-1120*</b>	<b>\$12.50</b>
G.		3 x 1mm	150	<b>240-1130</b>	<b>12.50</b>
H.		4 x 1mm	150	<b>240-1140</b>	<b>12.50</b>
I.		5 x 2mm	150	<b>240-1150</b>	<b>12.50</b>
J. Three-Square		2mm	150	<b>240-1520*</b>	<b>12.50</b>
K.		3.5mm	150	<b>240-1535</b>	<b>12.50</b>
L.		4.5mm	150	<b>240-1545</b>	<b>12.50</b>
M. Crossing		2 x 1mm	150	<b>240-1410*</b>	<b>12.50</b>
N. Round		1mm	150	<b>240-1310</b>	<b>12.50</b>
O.		2mm	150	<b>240-1320*</b>	<b>12.50</b>
P.		3mm	150	<b>240-1330</b>	<b>12.50</b>
Q. Flat		4 x 1mm	150	<b>240-1230*</b>	<b>12.50</b>
R. Knife		4 x 1mm	150	<b>240-1610*</b>	<b>12.50</b>
6-Piece Set (one of each asterisked item)				<b>240-1706</b>	<b>71.00</b>
12-Piece Set (one of each except #240-1150)				<b>240-1712</b>	<b>142.00</b>



**S - V Gesswein® Tapered Diamond Poli Files**

Tapered diamond machine files for use in reciprocating handpieces (see pp. 90, 109 and 113). All have 3mm shanks. Plated ends measure 15mm (19/32") long with 1.4-0.3mm taper.

Style	Shape	W x L	Grit	Item#	Each
S. Flat		3 x 56mm	200	<b>241-0814</b>	<b>\$12.50</b>
			400	<b>241-0815</b>	<b>12.50</b>
			600	<b>241-0816</b>	<b>12.50</b>
T.		6 x 56mm	200	<b>241-0817</b>	<b>13.75</b>
			400	<b>241-0818</b>	<b>13.75</b>
			600	<b>241-0819</b>	<b>13.75</b>
U.		3 x 72mm	200	<b>241-0820</b>	<b>12.50</b>
			400	<b>241-0821</b>	<b>12.50</b>
			600	<b>241-0822</b>	<b>12.50</b>
V.		6 x 72mm	200	<b>241-0823</b>	<b>13.75</b>
			400	<b>241-0824</b>	<b>13.75</b>
			600	<b>241-0825</b>	<b>13.75</b>
12-Piece Set (one of each)				<b>241-0813</b>	<b>149.75</b>



## Spectra Diamond Files

High-quality diamond files at economical prices. Feature a combination of natural and synthetic diamonds firmly plated onto durable steel blanks. Made in Germany.



### A - E Spectra Medium Diamond Needle Files

Diamond needle files with 3mm round handles. Measure 5½" (14cm) long. Plated ends measure 2¾" long. Medium grit (D126, or U.S. standard 120/140).

Style	Shape	Item#	EACH Prices		
			1-4	5-9	10+
A. Equalling		241-0010	\$29.00	\$27.55	\$26.10
B. Flat-Pointed		241-0020	29.00	27.55	26.10
C. Half-Round		241-0030	29.00	27.55	26.10
D. Round		241-0040	29.00	27.55	26.10
E. Knife		241-0050	29.00	27.55	26.10
5-Piece Set (one of each)		241-0250	137.00	-	-

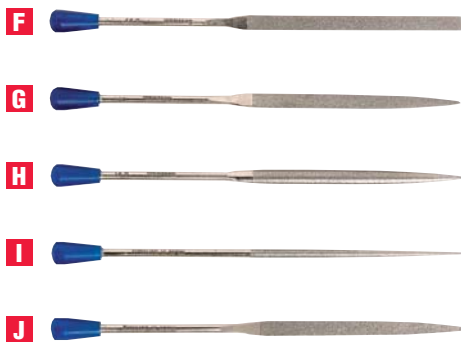

### F - J Spectra Fine Diamond Needle Files

Diamond needle files with 3mm round handles. Measure 5½" (14cm) long. Plated ends measure 2¾" long. Fine grit (D91, or U.S. standard 170/200).

Style	Shape	Item#	EACH Prices		
			1-4	5-9	10+
F. Equalling		241-0012	\$29.00	\$27.55	\$26.10
G. Flat-Pointed		241-0022	29.00	27.55	26.10
H. Half-Round		241-0032	29.00	27.55	26.10
I. Round		241-0042	29.00	27.55	26.10
J. Knife		241-0052	29.00	27.55	26.10
5-Piece Set (one of each)		241-0245	137.00	-	-



### K Spectra Diamond Escapement File

Diamond escapement file with 3/32" square handle. Measures 5½" (14cm) long. Plated end measures 1¾" long with 1/16"-1/32" taper. Very fine grit (D64, or U.S. standard 230/270).

Style	Shape	Item#	EACH Prices		
			1-4	5-9	10+
Round (tapered)		241-0150	\$29.95	\$28.45	\$26.96

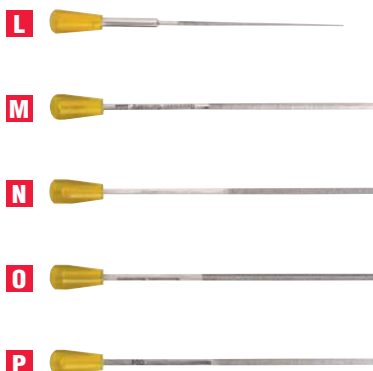





### L - P Spectra Diamond Micro Files

Mini diamond files with 3/32" wide handles. Measure approx. 4" long except round, which measures approx. 3¾" long. Plated ends measure approx. 2" long with 1/16"-1/32" taper for round only. Very fine grit (D64, or U.S. standard 230/270).

Style	Shape	Item#	EACH Prices		
			1-4	5-9	10+
L. Round (tapered)		241-0500	\$15.00	\$14.25	\$13.50
M. Half-Round		241-0505	15.00	14.25	13.50
N. Square		241-0510	15.00	14.25	13.50
O. Three-Square		241-0515	15.00	14.25	13.50
P. Flat Hand		241-0520	15.00	14.25	13.50
5-Piece Set (one of each)		241-0525	71.00	-	-

**A - E Spectra Diamond Rifflers – Medium and Fine**

Curved, double-ended diamond files with square handles. Measure 6" long. Plated ends measure 1" long. Medium grit (D126, or U.S. standard 120/140) and fine grit (D91, or U.S. standard 170/200).



Style	Shape	Medium Item#	Fine Item#	EACH Prices		
				1-4	5-9*	10+*
<b>A. Flat</b>		<b>241-0195</b>	<b>241-0170</b>	<b>\$35.00</b>	<b>\$33.25</b>	<b>\$31.50</b>
<b>B. Three-Square</b>		<b>241-0200</b>	<b>241-0175</b>	<b>35.00</b>	<b>33.25</b>	<b>31.50</b>
<b>C. Square</b>		<b>241-0205</b>	<b>241-0180</b>	<b>35.00</b>	<b>33.25</b>	<b>31.50</b>
<b>D. Round</b>		<b>241-0210</b>	<b>241-0185</b>	<b>35.00</b>	<b>33.25</b>	<b>31.50</b>
<b>E. Oval</b>		<b>241-0215</b>	<b>241-0190</b>	<b>35.00</b>	<b>33.25</b>	<b>31.50</b>
Set of all five		<b>241-0310</b>	<b>241-0305</b>	<b>165.00</b>	<b>-</b>	<b>-</b>

\*Quantity discount for orders of one item# only, not assorted.



**F - N Spectra Diamond Poli Files – Medium**

Parallel diamond machine files for use in reciprocating handpieces (see pp. 90, 109 and 113). All have 3mm shanks. Measure approx. 2" long. Plated ends measure 25mm long on #241-0420, #241-0435 and #241-0440, 15mm long on all others. Medium grit (D126, or U.S. standard 120/140).

Style	Shape	Plated Size (mm)	Item#	EACH Prices		
				1-4	5-9	10+
<b>F. Flat</b>		2 x 1mm	<b>241-0400</b>	<b>\$18.90</b>	<b>\$17.96</b>	<b>\$17.01</b>
<b>G.</b>		3 x 1mm	<b>241-0405</b>	<b>18.90</b>	<b>17.96</b>	<b>17.01</b>
<b>H.</b>		4 x 1mm	<b>241-0410</b>	<b>18.90</b>	<b>17.96</b>	<b>17.01</b>
<b>I.</b>		5 x 2mm	<b>241-0415</b>	<b>18.90</b>	<b>17.96</b>	<b>17.01</b>
<b>J.</b>		5 x 2mm	<b>241-0420</b>	<b>18.90</b>	<b>17.96</b>	<b>17.01</b>
<b>K. Flat</b>		2 x 1mm	<b>241-0425</b>	<b>18.90</b>	<b>17.96</b>	<b>17.01</b>
<b>L.</b>		3 x 1mm	<b>241-0430</b>	<b>18.90</b>	<b>17.96</b>	<b>17.01</b>
<b>M.</b>		5 x 2mm	<b>241-0435</b>	<b>18.90</b>	<b>17.96</b>	<b>17.01</b>
<b>N. Round</b>		3mm	<b>241-0440</b>	<b>18.90</b>	<b>17.96</b>	<b>17.01</b>
Set of all nine			<b>241-0445</b>	<b>160.00</b>	<b>152.00</b>	<b>144.00</b>



**O 3M® Diamond Hand Files**

For filing hard-to-cut materials, finishing delicate surfaces, beveling edges, removing burrs and sharpening tools. Can be used wet or dry. Color-coded for easy grit identification.

Cutting Face (L x W)	Color	Grit	Item#	Each
1½" x ¾"	Black	120	<b>240-3010</b>	<b>\$6.75</b>
	Red	200	<b>240-3011</b>	<b>6.30</b>
	Yellow	400	<b>240-3012</b>	<b>5.70</b>
	White	800	<b>240-3013</b>	<b>5.70</b>
1¾" x ½"	Black	120	<b>240-3014</b>	<b>6.40</b>
	Red	200	<b>240-3015</b>	<b>6.05</b>
	Yellow	400	<b>240-3016</b>	<b>5.55</b>
	White	800	<b>240-3017</b>	<b>5.55</b>
1¾" x ½" half-round	Black	120	<b>240-3018</b>	<b>6.45</b>
	Red	200	<b>240-3019</b>	<b>6.05</b>



**P Mini-Filer Diamond Tip Set**

Includes a variety of filing tips coated with synthetic diamonds, precisely bonded to obtain the best physical properties for added strength and wear. These tips can be used in our Mini-Filer (see pp. 96 and 109) and other light-duty profiling handpieces. Total of 10 tips: four rectangular and four spatula tips (9.5mm coated length, grits 30, 50, 100 and 150); one 45° spatula tip (9mm coated length, grit 50); and one knife-edge tip (8mm coated length, grit 100). All measure .5mm thick x approx. 23mm long.

Description	Item#	Each
Mini-Filer Diamond Tip Set (includes 10 tips, stand and two tip holders)	<b>241-0600</b>	<b>\$169.00</b>





**A**



**B**



**C**



**D**



**E**



**F**

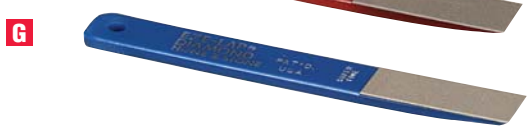

**G**



**H**



**I**



**J**



**K**

**A Offhand Wheel Dresser**

Has 35 to 40 exposed diamond points set in a carbide matrix. Sturdy construction with comfortable, sure-grip plastic handle. Measures 9<sup>3</sup>/<sub>4</sub>" long.

Description	Item#	Each
Wheel Dresser	<b>220-4050</b>	<b>\$64.75</b>

**B Diamond Hand Lapper**

Lightweight lapper for touching up and sharpening carbide and high-speed steels. Cuts very well and leaves a good finish due to its resin bonding. Fine grit diamond (D91). Measures 6" long with <sup>3</sup>/<sub>8</sub>" x <sup>9</sup>/<sub>16</sub>" diamond surface.

Description	Item#	Each
Diamond Hand Lapper	<b>240-3000</b>	<b>\$67.65</b>

**C - G EZE-LAP® Diamond Hand Lappers**

These lappers are ideally suited for honing edges of carbide cutting tools. They offer excellent abrasion resistance for superior finishing. Available in assorted grits to match your finishing requirements. Comfort-fit handgrips are designed for accurate control and color-coded for easy grit identification. Measure 6"L x <sup>3</sup>/<sub>4</sub>"W (diamond face area measures 2"L x <sup>3</sup>/<sub>4</sub>"W).

Hand Lappers	Color	Item#	Each
<b>C. Extra-Coarse</b>	Green	<b>349-6009</b>	<b>\$10.95</b>
<b>D. Coarse (200)</b>	Black	<b>349-6010</b>	<b>8.75</b>
<b>E. Medium (325)</b>	Purple	<b>349-6012</b>	<b>7.15</b>
<b>F. Fine (600)</b>	Red	<b>349-6014</b>	<b>5.45</b>
<b>G. Super-Fine (1500)</b>	Blue	<b>349-6018</b>	<b>5.45</b>

**H - J EZE-LAP® Diamond Hand Sharpeners**

These sharpeners are ideally suited for honing edges of carbide cutting tools. They offer excellent abrasion resistance for superior finishing. Available in assorted grits to match your finishing requirements. Folding sharpeners with butterfly knife-style handles are grit color-coded and measure 9"L x 1"W open, 5"L x 1"W closed (diamond face area measures 4"L x <sup>3</sup>/<sub>4</sub>"W). Sharpeners measure 4"L x 1"W (each includes carrying pouch).

Folding Sharpeners	Color	Item#	Each
<b>H. Fine/Medium</b>	Silver	<b>349-6020</b>	<b>\$32.95</b>
<b>I. Fine (tapered cone)</b>	Red	<b>349-6022</b>	<b>24.15</b>

Sharpeners	Item#	Each
<b>J. Medium (325)</b>	<b>349-6026</b>	<b>\$12.65</b>
Fine (600)	<b>349-6024</b>	<b>10.45</b>

**K Diamond Scriber**

Diamond point set in nonroll hexagonal handle. Will mark any metal. Measures 5<sup>1</sup>/<sub>4</sub>" long.

Description	Item#	EACH Prices	
		1-2	3+
Diamond Scriber	<b>220-1900</b>	<b>\$9.97</b>	<b>\$8.97</b>



**A - F Diamond Grinding Wheels – 150 grit, 100 concentration**

Feature man-made diamond, more consistent in shape than natural diamond, for sharp, even cutting action, durability and long life. Resin-bonded to produce a self-sharpening effect and even grit distribution. Can be used wet or dry on carbide, ceramic, glass, welds, quartz and other hard, brittle and short chipping materials.

**A Shape 11V9D**

Diameter (D)	Diamond Depth (X)	Item#	Each
3.75"	1/16"	<b>245-1020</b>	<b>\$75.00</b>
3.75"	1/8"	<b>245-1050</b>	<b>90.00</b>
5"	1/16"	<b>245-1120</b>	<b>103.50</b>
5"	1/8"	<b>245-1150</b>	<b>132.00</b>

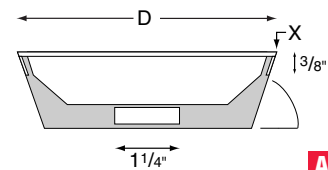

**B Shape 6A2C**

Diameter	Grinding Surface	Diamond Depth	Item#	Each
6"	3/4"	1/16"	<b>245-1200</b>	<b>\$114.00</b>

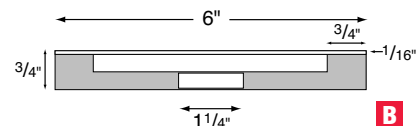

**C Shape 11A2**

Hole (H)	Grinding Surface (W)	Diamond Depth (X)	Item#	Each
1 1/4"	3/8"	1/16"	<b>245-2150</b>	<b>\$81.00</b>
1 1/4"	3/8"	1/8"	<b>245-2160</b>	<b>105.00</b>
20mm*	3/8"	1/16"	<b>245-2155</b>	<b>81.00</b>
20mm*	3/8"	1/8"	<b>245-2165</b>	<b>105.00</b>

\*20mm hole size used for Deckel machines.

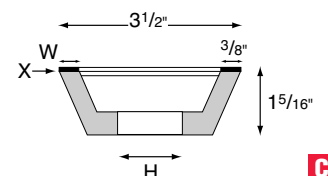

**D Shape 12A2**

Diameter	Grinding Surface	Diamond Depth	Item#	Each
6"	3/16"	1/16"	<b>245-1250</b>	<b>\$79.50</b>
6"	3/16"	1/8"	<b>245-1255</b>	<b>114.00</b>

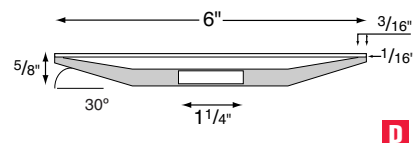

**E Shape 1A1**

Diameter	Grinding Surface	Diamond Depth	Item#	Each
6"	1/4"	1/8"	<b>245-1450</b>	<b>\$87.00</b>

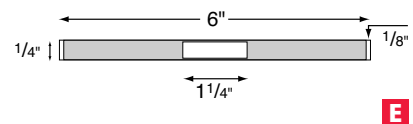

**F Shape 1A1R**

Diameter	Grinding Surface	Diamond Depth	Item#	Each
6"	0.035"	.028"	<b>245-1620</b>	<b>\$75.00</b>

Note: 1A1R can be fitted with bushing to create standard bore sizes under 1 1/4".

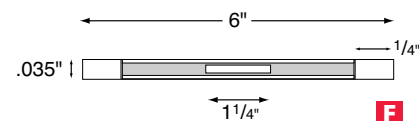

**G Diamond Cup Wheels – Electroplated**

Ideal for sharpening of carbide tools. Tough nickel is electroplated over diamonds on a perforated steel sheet until the diamonds are approximately two-thirds buried in metal. This process ensures a durable grip and good heat removal. Because the steel is perforated with 1/8" holes in 3/16" staggered centers, it provides aggressive, cool and fast grinding, creating less disturbance of the metal surface. This type of construction creates less heat and allows the coolant to be held on the wheel for a longer period of time. The self-cleaning pattern resists loading.

Diameter	Grit	Item#	Each
6"	100	<b>845-3655</b>	<b>\$120.00</b>
6"	180	<b>845-3665</b>	<b>114.50</b>

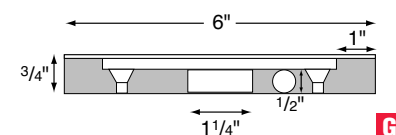

## Diamond and CBN Pins

Diamond and CBN (cubic boron nitride) are superior abrasives with material removal rates beyond those of conventional abrasives such as aluminum oxide or silicon carbide. Our diamond pins are ideal for use on carbides and extremely hard steels and ceramics. Our CBN pins are recommended for use on high-carbon, high-chrome, high-speed steels such as

M2, M3, M7 and T15; die steels such as D2, D3, HB and A&O; alloy steels harder than 50 HRC; and nickel- and cobalt-based super alloys such as titanium and stainless steel. The cutting edges last longer, resist breakdown better, produce more ground parts per hour and improve the quality of the finished product, helping reduce overall costs. When heat distortion is an

important factor, CBN is the wise choice because it runs cooler than diamond.

Diameter	Maximum RPM
.020"–.200"	60,000–120,000
.200"–.500"	45,000–60,000
.500"–1.00"	30,000–45,000

**Maximum 1/2" overhang.**

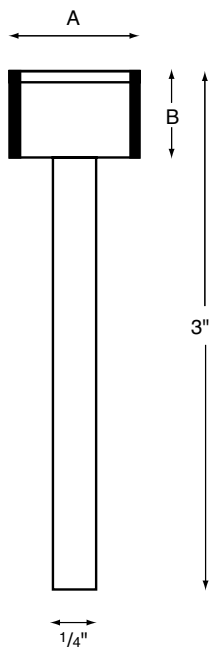

### BX and GX Series (BX = CBN, GX = Diamond) – 1/4" Shank

BX are all 80/100 grit. GX are as follows: coarse is 100/120 grit, fine is 140/170 grit. Measure 3" long.

Dimensions		BX Series		GX Series		GX Series		Each
A	B	Style	Item#	Coarse Style	Item#	Fine Style	Item#	
9/64"	1/4"	BX-141	<b>247-1410</b>	GX-141C	<b>235-3601</b>	GX-141F	<b>235-3600</b>	<b>\$15.00</b>
5/32"	1/4"	BX-156	<b>247-1560</b>	GX-156C	<b>235-3651</b>	GX-156F	<b>235-3650</b>	<b>15.00</b>
3/16"	1/4"	BX-188	<b>247-1880</b>	GX-188C	<b>235-3701</b>	GX-188F	<b>235-3700</b>	<b>15.00</b>
7/32"	1/4"	BX-218	<b>247-2180</b>	GX-218C	<b>235-3751</b>	GX-218F	<b>235-3750</b>	<b>15.00</b>
1/4"	1/8"	BX-250/2	<b>247-2502</b>	GX-250/2C	<b>235-3801</b>	GX-250/2F	<b>235-3800</b>	<b>16.75</b>
1/4"	1/4"	BX-250/4	<b>247-2504</b>	GX-250/4C	<b>235-3851</b>	GX-250/4F	<b>235-3850</b>	<b>16.75</b>
5/16"	1/4"	BX-312/4	<b>247-3124</b>	–	–	GX-312/4F	<b>235-3950</b>	<b>16.95</b>
5/16"	3/8"	BX-312/6	<b>247-3126</b>	GX-312/6C	<b>235-4001</b>	GX-312/6F	<b>235-4000</b>	<b>16.95</b>
3/8"	1/8"	BX-375/2	<b>247-3752</b>	GX-375/2C	<b>235-4051</b>	GX-375/2F	<b>235-4050</b>	<b>21.50</b>
3/8"	1/4"	BX-375/4	<b>247-3754</b>	GX-375/4C	<b>235-4101</b>	GX-375/4F	<b>235-4100</b>	<b>21.50</b>
3/8"	3/8"	BX-375/6	<b>247-3756</b>	GX-375/6C	<b>235-4151</b>	GX-375/6F	<b>235-4150</b>	<b>21.50</b>
1/2"	1/4"	BX-500/4	<b>247-5004</b>	–	–	–	–	<b>25.00</b>
1/2"	3/8"	BX-500/6	<b>247-5006</b>	GX-500/6C	<b>235-4251</b>	GX-500/6F	<b>235-4250</b>	<b>25.00</b>
1/2"	1/2"	BX-500/8	<b>247-5008</b>	GX-500/8C	<b>235-4301</b>	GX-500/8F	<b>235-4300</b>	<b>25.00</b>
3/4"	1/4"	BX-750/4	<b>247-7504</b>	GX-750/4C	<b>235-4351</b>	GX-750/4F	<b>235-4350</b>	<b>38.00</b>
3/4"	1/2"	BX-750/8	<b>247-7508</b>	GX-750/8C	<b>235-4401</b>	GX-750/8F	<b>235-4400</b>	<b>38.00</b>

### G Series Diamond Pins – 1/8" Shank

Coarse is 140/170 grit, fine is 200/230 grit. Measure 1 3/8" long.

Dimensions			Coarse Style		Fine Style		Each
A	B	C	Style	Item#	Style	Item#	
0.02"	1/16"	1/8"	G-20C	<b>235-1451</b>	G-20F	<b>235-1450</b>	<b>\$8.60</b>
0.025"	3/32"	1/4"	G-25C	<b>235-1501</b>	G-25F	<b>235-1500</b>	<b>8.60</b>
0.03"	3/32"	1/4"	G-30C	<b>235-1551</b>	G-30F	<b>235-1550</b>	<b>8.00</b>
0.035"	3/32"	1/4"	G-35C	<b>235-1601</b>	G-35F	<b>235-1600</b>	<b>8.00</b>

Coarse is 100/120 grit, fine is 200/230 grit. Measure 1 3/8" long.

Dimensions			Coarse Style		Fine Style		Each
A	B	C	Style	Item#	Style	Item#	
0.04"	1/8"	3/8"	G-40C	<b>235-1651</b>	G-40F	<b>235-1650</b>	<b>\$8.00</b>
0.045"	1/8"	3/8"	G-45C	<b>235-1701</b>	G-45F	–	<b>8.00</b>
0.05"	1/8"	3/8"	G-50C	<b>235-1751</b>	G-50F	<b>235-1750</b>	<b>8.00</b>
0.055"	1/8"	3/8"	G-55C	<b>235-1801</b>	G-55F	–	<b>8.00</b>
0.06"	1/8"	3/8"	G-60C	<b>235-1851</b>	G-60F	<b>235-1850</b>	<b>8.00</b>
0.07"	5/32"	1/2"	G-70C	<b>235-1901</b>	G-70F	<b>235-1900</b>	<b>8.00</b>
0.08"	5/32"	1/2"	G-80C	<b>235-1951</b>	G-80F	<b>235-1950</b>	<b>8.00</b>
0.09"	5/32"	1/2"	G-90C	<b>235-2001</b>	G-90F	<b>235-2000</b>	<b>8.00</b>
0.1"	5/32"	1/2"	G-100C	<b>235-2051</b>	G-100F	<b>235-2050</b>	<b>8.00</b>
0.11"	5/32"	1/2"	G-110C	<b>235-2101</b>	G-110F	<b>235-2100</b>	<b>8.00</b>
0.125"	5/32"	1/2"	G-125C	<b>235-2151</b>	G-125F	<b>235-2150</b>	<b>8.00</b>

**BL and GL Series (BL = CBN, GL = Diamond) – 1/8" Shank**

BL are all 140/170 grit. GL are as follows: coarse is 140/170 grit, fine is 200/230 grit. Measure 2 1/2" long.

Dimensions			BL Series		GL Series		GL Series		Each
A	B	C	Style	Item#	Coarse Style	Item#	Fine Style	Item#	
0.02"	1/16"	1/8"	BL-20	<b>246-0200</b>	–	–	GL-20F	<b>235-2200</b>	<b>\$9.25</b>
0.025"	3/32"	1/4"	BL-25	<b>246-0250</b>	GL-25C	<b>235-2251</b>	GL-25F	<b>235-2250</b>	<b>9.25</b>
0.03"	3/32"	1/4"	BL-30	<b>246-0300</b>	GL-30C	<b>235-2276</b>	GL-30F	<b>235-2275</b>	<b>8.00</b>
0.035"	3/32"	1/4"	BL-35	<b>246-0350</b>	–	–	–	–	<b>8.00</b>

BL are all 80/100 grit. GL are as follows: coarse is 100/120 grit, fine is 200/230 grit. Measure 2 1/2" long.

Dimensions			BL Series		GL Series		GL Series		Each
A	B	C	Style	Item#	Coarse Style	Item#	Fine Style	Item#	
0.04"	1/8"	3/8"	BL-40	<b>246-0400</b>	GL-40C	<b>235-2351</b>	GL-40F	<b>235-2350</b>	<b>\$8.00</b>
0.045"	1/8"	3/8"	BL-45	<b>246-0450</b>	–	–	–	–	<b>8.00</b>
0.05"	1/8"	1"	BL-50/1	<b>246-0501</b>	GL-50/1C	<b>235-2501</b>	–	–	<b>9.25</b>
0.05"	1/8"	3/8"	BL-50	<b>246-0500</b>	GL-50C	<b>235-2451</b>	GL-50F	<b>235-2450</b>	<b>8.00</b>
0.055"	1/8"	3/8"	BL-55	<b>246-0550</b>	–	–	–	–	<b>8.00</b>
0.06"	1/8"	3/8"	BL-60	<b>246-0600</b>	GL-60C	<b>235-2601</b>	GL-60F	<b>235-2600</b>	<b>8.00</b>
0.06"	1/8"	1"	BL-60/1	<b>246-0601</b>	–	–	–	–	<b>9.25</b>
0.07"	5/32"	1/2"	BL-70	<b>246-0700</b>	GL-70C	<b>235-2701</b>	GL-70F	<b>235-2700</b>	<b>8.00</b>
0.07"	5/32"	1"	BL-70/1	<b>246-0701</b>	GL-70/1C	<b>235-2751</b>	GL-70/1F	<b>235-2750</b>	<b>9.25</b>
0.08"	5/32"	1/2"	BL-80	<b>246-0800</b>	GL-80C	<b>235-2801</b>	GL-80F	<b>235-2800</b>	<b>8.00</b>
0.09"	5/32"	1/2"	BL-90	<b>246-0900</b>	GL-90C	<b>235-2901</b>	GL-90F	<b>235-2900</b>	<b>8.00</b>
0.09"	5/32"	1"	BL-90/1	<b>246-0901</b>	–	–	–	–	<b>9.75</b>
0.1"	5/32"	1/2"	BL-100	<b>246-1000</b>	GL-100C	<b>235-3001</b>	GL-100F	<b>235-3000</b>	<b>8.00</b>
0.1"	5/32"	1"	BL 100/1	<b>246-1001</b>	–	–	–	–	<b>9.75</b>
0.11"	5/32"	1/2"	BL-110	<b>246-1100</b>	–	–	–	–	<b>8.00</b>
0.11"	5/32"	1"	BL-110/1	<b>246-1101</b>	–	–	–	–	<b>9.75</b>
0.125"	5/32"	1/2"	BL-125	<b>246-1250</b>	GL-125C	<b>235-3201</b>	GL-125F	<b>235-3200</b>	<b>8.00</b>
0.125"	5/32"	1"	BL-125/1	<b>246-1251</b>	–	–	–	–	<b>9.75</b>
0.141"	1/4"	–	BL-141	<b>246-1410</b>	GL-141C	<b>235-3301</b>	GL-141F	<b>235-3300</b>	<b>9.75</b>
0.156"	1/4"	–	BL-156	<b>246-1561</b>	GL-156C	<b>235-3351</b>	GL-156F	<b>235-3350</b>	<b>9.75</b>
0.188"	1/4"	–	BL-188	<b>246-1880</b>	GL-188C	<b>235-3401</b>	GL-188F	<b>235-3400</b>	<b>14.00</b>
0.218"	1/4"	–	BL-218	<b>246-2180</b>	GL-218C	<b>235-3451</b>	GL-218F	<b>235-3450</b>	<b>14.50</b>
0.25"	1/8"	–	–	–	GL-250/2C	<b>235-3501</b>	GL-250/2F	<b>235-3500</b>	<b>15.00</b>
0.25"	1/8"	–	BL-250/2	<b>246-2502</b>	–	–	–	–	<b>15.00</b>
0.25"	1/4"	–	BL-250/4	<b>246-2504</b>	GL-250/4C	<b>235-3551</b>	GL-250/4F	<b>235-3550</b>	<b>15.00</b>

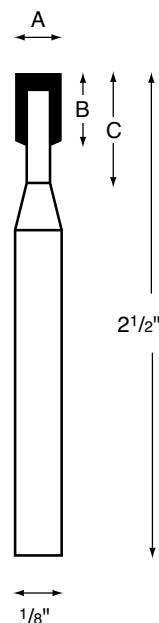

**A Super Dresser**

Used to dress Super Ceramic Stones and Diamond or CBN Wheels. Measures 1/8" x 1" x 1/4" (3 x 25 x 100mm).

Description	Item#	Each
Super Dresser	<b>351-0300</b>	<b>\$13.45</b>



**A**

## Single Point Diamond Tools

For truing and dressing abrasive wheels where precision, close-tolerance, high-finish grinding is required. Straight face, radius and form wheel dressing operations can be performed with accuracy and economy. All natural diamond.

### A Diamond Cone Points

Used for accurate wheel forming.

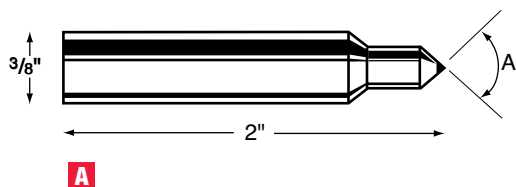

Style	Dia. x L	Carat Size	Angle (A)	Item#	Each
CP1	3/8" x 2"	0.25	60°	<b>220-2160</b>	<b>\$67.60</b>
CP1	3/8" x 2"	0.25	75°	<b>220-2175</b>	<b>59.90</b>
CP1	3/8" x 2"	0.25	90°	<b>220-2190</b>	<b>52.10</b>
CP2	3/8" x 2"	0.3	60°	<b>220-2260</b>	<b>87.45</b>
CP2	3/8" x 2"	0.3	75°	<b>220-2275</b>	<b>77.35</b>
CP2	3/8" x 2"	0.3	90°	<b>220-2290</b>	<b>64.30</b>
CP3	3/8" x 2"	0.5	60°	<b>220-2360</b>	<b>117.85</b>
CP3	3/8" x 2"	0.5	75°	<b>220-2375</b>	<b>101.35</b>
CP3	3/8" x 2"	0.5	90°	<b>220-2390</b>	<b>83.45</b>

### B Diamond Chisel-Edge Points

Used for accurate wheel forming.

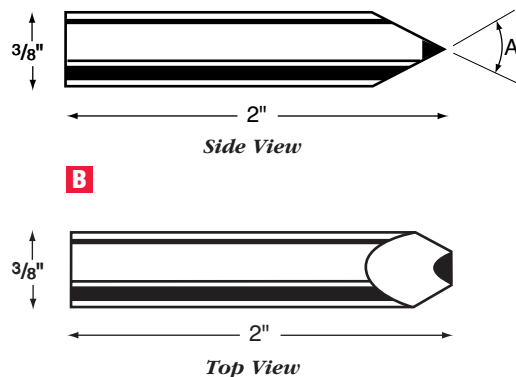

Style	Dia. x L	Carat Size	Angle (A)	Item#	Each
CE1	3/8" x 2"	0.25	60°	<b>220-3160</b>	<b>\$68.50</b>
CE1	3/8" x 2"	0.25	75°	<b>220-3175</b>	<b>65.25</b>
CE1	3/8" x 2"	0.25	90°	<b>220-3190</b>	<b>61.80</b>
CE2	3/8" x 2"	0.3	60°	<b>220-3260</b>	<b>95.85</b>
CE2	3/8" x 2"	0.3	75°	<b>220-3275</b>	<b>87.05</b>
CE2	3/8" x 2"	0.3	90°	<b>220-3290</b>	<b>82.90</b>
CE3	3/8" x 2"	0.5	60°	<b>220-3360</b>	<b>144.95</b>
CE3	3/8" x 2"	0.5	75°	<b>220-3375</b>	<b>127.85</b>
CE3	3/8" x 2"	0.5	90°	<b>220-3390</b>	<b>112.70</b>

### C Regular and Select Point Diamond Dressers

Two qualities of diamonds are offered: the select-style stones have four to six usable points, and the regular-style stones have two to three usable points. Both styles can be reset. REG = regular diamond, SEL = select diamond.

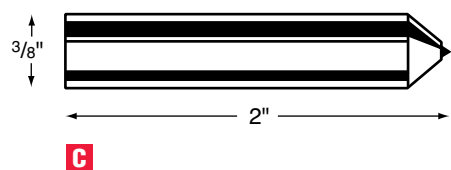

Style	Dia. x L	Carat Size	Item#	Each
1REG	3/8" x 2"	0.25	<b>220-1100</b>	<b>\$27.60</b>
1SEL	3/8" x 2"	0.25	<b>220-1150</b>	<b>40.80</b>
2REG	3/8" x 2"	0.35	<b>220-1200</b>	<b>34.30</b>
2SEL	3/8" x 2"	0.35	<b>220-1250</b>	<b>50.80</b>
3REG	3/8" x 2"	0.5	<b>220-1300</b>	<b>50.40</b>
3SEL	3/8" x 2"	0.5	<b>220-1350</b>	<b>68.80</b>
4REG	3/8" x 2"	0.6	<b>220-1400</b>	<b>66.55</b>
4SEL	3/8" x 2"	0.6	<b>220-1450</b>	<b>90.85</b>

### D Expendable Diamond Dressers

Throwaway economical dressing tools. Each has a natural diamond securely mounted so its sharpest point is exposed.

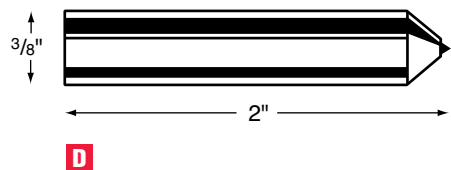

Style	Dia. x L	Carat Size	Item#	EACH Prices	
				1-11	12+
E41	1/4" x 7/8"	0.25	<b>220-0050</b>	<b>\$13.30</b>	<b>\$12.64</b>
E62	3/8" x 1 7/8"	0.25	<b>220-0100</b>	<b>13.30</b>	<b>12.64</b>
66	3/8" x 6"	0.25	<b>220-1860</b>	<b>15.70</b>	<b>14.92</b>
E72	7/16" x 1 7/8"	0.25	<b>220-0150</b>	<b>13.30</b>	<b>12.64</b>
E82	1/2" x 1 7/8"	0.25	<b>220-0200</b>	<b>13.35</b>	<b>12.68</b>



**A Cluster Diamond Dresser CL-18**

A universal cluster tool for small surface and cylindrical grinders. Contains 18 diamonds. Six are exposed for immediate use; others appear as dresser wears down.

Style	Dia. x L	Item#	Each
CL-18	7/16" x 2"	<b>220-4150</b>	<b>\$44.10</b>

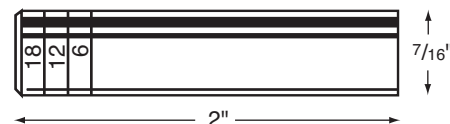

**B Heavy-Duty Cluster Diamond Dresser HD-15**

For roughing out or for commercial finish. Nib is loaded with 15 diamonds. Five are exposed for immediate use; others appear as dresser wears down.

Style	Dia. x L	Item#	Each
HD-15	7/16" x 2"	<b>220-4200</b>	<b>\$59.55</b>



**C Cluster Diamond Dresser CB-24**

A bullet-nose carbide bond impregnated dresser randomly set throughout with 24 small diamonds for rough dressing operations on 36 to 60 grit abrasive wheels.

Style	Dia. x L	Item#	Each
CB-24	7/16" x 2"	<b>220-4100</b>	<b>\$44.10</b>

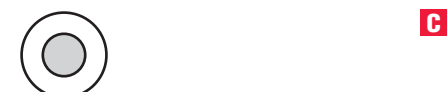
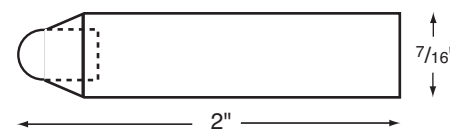

**D Cluster Diamond Dresser PG-4R**

A flat-faced nickel alloy matrix dresser containing many particles of diamond sand spaced precisely for dressing operations on 80 grit or finer abrasive wheels.

Style	Dia. x L	Item#	Each
PG-4R	7/16" x 2"	<b>220-4250</b>	<b>\$44.10</b>

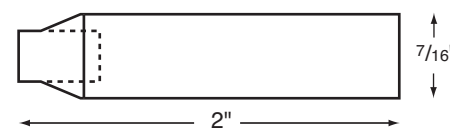

**E Diamond Phono Points**

High-quality miniature points with full-size, long-lasting diamonds for accurate wheel forming and intricate, small radius dressing.

Size	Dia. x L	Angle (A)	Item#	Each
Small	.080" x 1/2"	60°	<b>220-0700</b>	<b>\$6.45</b>
Small	.080" x 1/2"	75°	<b>220-0750</b>	<b>6.20</b>
Small	.080" x 1/2"	90°	<b>220-0800</b>	<b>5.15</b>
Large	1/8" x 1"	60°	<b>220-0550</b>	<b>6.70</b>
Large	1/8" x 1"	75°	<b>220-0600</b>	<b>6.45</b>
Large	1/8" x 1"	90°	<b>220-0650</b>	<b>5.35</b>

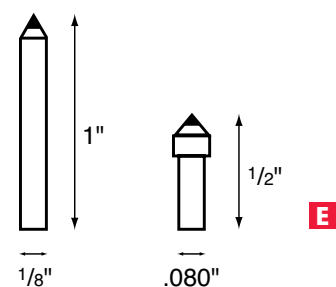

## Diamond Wheels and Points

A wide variety of shapes and sizes of diamond wheels convenient for cutting hard metals, ceramics, stones and more. A single layer of diamond is nickel-electroplated

to each wheel, ensuring long life when used with only slight pressure. The diamonds are in an exposed position for fast cutting action. All are 140/170 grit with  $\frac{3}{32}$ " shanks.

Diameter	Maximum RPM
.020"–.200"	60,000–120,000
.200"–.500"	45,000–60,000
.500"–1.00"	30,000–45,000

**Maximum  $\frac{1}{2}$ " overhang.**

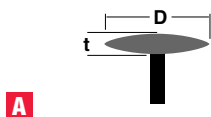

A	Style	Dimensions (inches)		Item#	Each
		D	t		
	DT-112	0.161	0.059	<b>230-2200</b>	<b>\$29.95</b>
	DT-109	0.366	0.051	<b>230-2050</b>	<b>45.25</b>



B	Style	Dimensions (inches)		Item#	Each
		D	t		
	DT-129P	0.248	0.02	<b>230-2850</b>	<b>\$35.50</b>
	DT-105P	0.252	0.035	<b>230-1850</b>	<b>36.75</b>

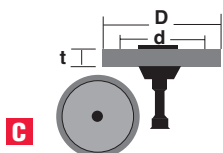

C	Style	Dimensions (inches)			Item#	Each
		D	d	t		
	DT-72P	0.677	0.575	0.094	<b>230-0650</b>	<b>\$62.60</b>

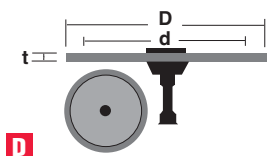

D	Style	Dimensions (inches)			Item#	Each
		D	d	t		
	DT-124P	0.602	0.512	0.018	<b>230-2600</b>	<b>\$47.50</b>
	DT-125P	0.721	0.630	0.018	<b>230-2650</b>	<b>47.95</b>
	DT-127P	0.878	0.787	0.020	<b>230-2750</b>	<b>43.75</b>

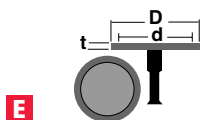

E	Style	Dimensions (inches)			Item#	Each
		D	d	t		
	DT-128P	0.361	0.276	0.02	<b>230-2800</b>	<b>\$39.95</b>
	DT-56P	0.343	0.268	0.051	<b>230-0350</b>	<b>39.95</b>



F	Style	Dimensions (inches)		Item#	Each
		D	t		
	DB-902A	0.051	0.158	<b>230-4050</b>	<b>\$12.85</b>
	DT-95	0.063	0.295	<b>230-1450</b>	<b>15.75</b>
	DT-509	0.063	0.394	<b>230-3050</b>	<b>18.50</b>
	DT-117	0.094	0.295	<b>230-2450</b>	<b>18.45</b>
	DT-510	0.094	0.394	<b>230-3100</b>	<b>18.65</b>



G	Style	Dimensions (inches)			Item#	Each
		D	d	t		
	DB-502	0.051	0.028	0.197	<b>230-3900</b>	<b>\$14.25</b>

A Style	Dimensions (inches)			Item#	Each
	D	Taper	t		
DT-94	0.122	31°	0.189	<b>230-1400</b>	<b>\$28.15</b>
DT-103	0.169	80°	0.106	<b>230-1750</b>	<b>29.35</b>
DT-236	0.287	60°	0.236	<b>230-3000</b>	<b>39.50</b>



**A**

B Style	Dimensions (inches)		Item#	Each
	D			
DB-2/0	0.032		<b>230-3250</b>	<b>\$12.95</b>
DB-102	0.051		<b>230-3300</b>	<b>12.95</b>
DB-104	0.067		<b>230-3350</b>	<b>12.95</b>
DB-105	0.071		<b>230-3400</b>	<b>12.95</b>
DB-108	0.098		<b>230-3450</b>	<b>13.95</b>
DT-101	0.118		<b>230-1650</b>	<b>20.45</b>
DT-119	0.158		<b>230-2550</b>	<b>26.05</b>



**B**

C Style	Dimensions (inches)		Item#	Each
	D	t		
DT-86	0.055	0.276	<b>230-1200</b>	<b>\$13.70</b>
DB-305	0.075	0.196	<b>230-3850</b>	<b>13.95</b>
DT-114	0.087	0.276	<b>230-2300</b>	<b>16.35</b>
DT-100	0.098	0.276	<b>230-1600</b>	<b>16.90</b>

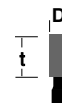

**C**

D Style	Dimensions (inches)		Item#	Each
	D	t		
DT-116	0.232	0.236	<b>230-2400</b>	<b>\$38.95</b>

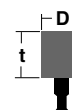

**D**

**E - N Diamond Cutters**

Feature premium-grade, high-impact-strength industrial diamonds electroplated onto ten different shapes. This process provides a super-abrasive grinding and cutting system. The diamonds protrude from the bond so that only the abrasive crystals are in contact with the workpiece. This greatly reduces frictional heat and thermal distortion of the work surface. The use of a coolant (we recommend Gesswein Stoning and Lubricating Oil—see p. 31) will maximize tool life and be a great aid where minimum heat distortion is required. Max. operating speed: 60,000rpm. All are 150 grit with 3/32" shanks.

Style	Style#	Item#	Each
<b>E.</b> Countersink, 60°	101	<b>226-1010</b>	<b>\$18.15</b>
<b>F.</b> Countersink, 90°	102	<b>226-1020</b>	<b>18.15</b>
<b>G.</b> Ball, 3mm	103	<b>226-1030</b>	<b>18.15</b>
<b>H.</b> Wheel, 6mm x 1mm	104	<b>226-1040</b>	<b>18.15</b>
<b>I.</b> Reamer, 2mm x 1mm taper	105	<b>226-1050</b>	<b>18.15</b>
<b>J.</b> Solid, 1.5mm	106	<b>226-1060</b>	<b>18.15</b>
<b>K.</b> Solid, 2mm	107	<b>226-1070</b>	<b>18.15</b>
<b>L.</b> Core Drill, 2mm	108	<b>226-1080</b>	<b>18.15</b>
<b>M.</b> Core Drill, 2.5mm	109	<b>226-1090</b>	<b>18.15</b>
<b>N.</b> Core Drill, 3mm	110	<b>226-1100</b>	<b>18.15</b>

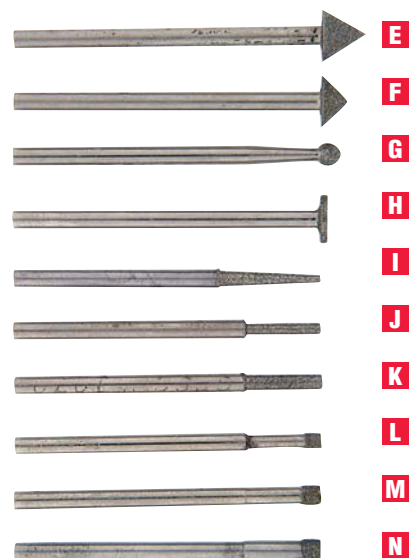



**A High-Speed Mini Diamond Points – 1/16" Shank**

Premium points for use in high-speed, air-driven turbo handpieces with maximum operating speeds up to 80,000rpm. Feature diamond particles electroplated onto surgical-grade steel. Measure an average of 3/4" (20mm) long with 1/16" shanks. Sold individually and in sets of 12 and 24. Always use with water or Lubricant/Thinner (see p. 145). Choose from coarse (120 grit) and fine (260 grit). Mount in collet-type handpieces with one of our reducing collets (see below).



Coarse Item#	<b>226-1602*</b>	<b>226-1603</b>	<b>226-1604*</b>	<b>226-1605*</b>	<b>226-1606*</b>	<b>226-1607</b>
Fine Item#	<b>226-1632*</b>	<b>226-1633</b>	<b>226-1634*</b>	<b>226-1635*</b>	<b>226-1636*</b>	<b>226-1637</b>
Each	<b>\$2.90</b>	<b>\$2.90</b>	<b>\$2.90</b>	<b>\$2.90</b>	<b>\$2.90</b>	<b>\$2.90</b>

*Six-piece minimum; please order in multiples of six.*



Coarse Item#	<b>226-1608*</b>	<b>226-1609</b>	<b>226-1610*</b>	<b>226-1611</b>	<b>226-1612</b>	<b>226-1613</b>
Fine Item#	<b>226-1638*</b>	<b>226-1639</b>	<b>226-1640*</b>	<b>226-1641</b>	<b>226-1642</b>	<b>226-1643</b>
Each	<b>\$2.90</b>	<b>\$2.90</b>	<b>\$2.90</b>	<b>\$2.90</b>	<b>\$2.90</b>	<b>\$2.90</b>

*Six-piece minimum; please order in multiples of six.*

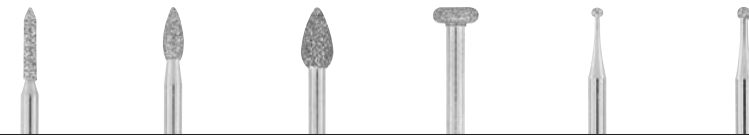

Coarse Item#	<b>226-1614</b>	<b>226-1615</b>	<b>226-1616*</b>	<b>226-1617</b>	<b>226-1618*</b>	<b>226-1619</b>
Fine Item#	<b>226-1644</b>	<b>226-1645</b>	<b>226-1646*</b>	<b>226-1647</b>	<b>226-1648*</b>	<b>226-1649</b>
Each	<b>\$2.90</b>	<b>\$2.90</b>	<b>\$2.90</b>	<b>\$2.90</b>	<b>\$2.90</b>	<b>\$2.90</b>

*Six-piece minimum; please order in multiples of six.*



Coarse Item#	<b>226-1620*</b>	<b>226-1621</b>	<b>226-1622*</b>	<b>226-1623*</b>	<b>226-1624</b>	<b>226-1625*</b>
Fine Item#	<b>226-1650*</b>	<b>226-1651</b>	<b>226-1652*</b>	<b>226-1653*</b>	<b>226-1654</b>	<b>226-1655*</b>
Each	<b>\$2.90</b>	<b>\$2.90</b>	<b>\$2.90</b>	<b>\$2.90</b>	<b>\$2.90</b>	<b>\$2.90</b>

*Six-piece minimum; please order in multiples of six.*

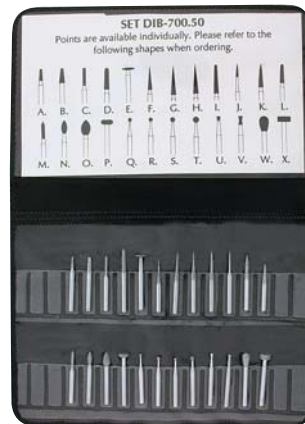

**B, C High-Speed Mini Diamond Point Sets – 1/16" Shank**

Description	Coarse Item#	Fine Item#	Each
<b>B. 12-Piece Set (asterisked above)</b>	<b>226-1601</b>	<b>226-1631</b>	<b>\$32.25</b>
<b>C. 24-Piece Set (one each of above)</b>	<b>226-1600</b>	<b>226-1630</b>	<b>64.50</b>

**D - F Reducing Collets**

Use proper reducing collet to convert your standard 3mm, 1/8" or 3/32" collet to hold 1/16" shank tools. Simply slip reducing collet into your rotary handpiece collet. Make sure both reducing collet and tool shank are fully inserted. Stainless steel.



















Size	Item#	Each
<b>D. 3mm to 1/16"</b>	<b>816-1505</b>	<b>\$12.90</b>
<b>E. 1/8" to 1/16"</b>	<b>816-1502</b>	<b>12.90</b>
<b>F. 3/32" to 1/16"</b>	<b>816-1503</b>	<b>12.90</b>

















**A Diamond Mounted Points – 1/8" Shank**

These inexpensive yet durable cutting tools feature diamond particles nickel-electroplated onto medium carbon steel. Use on carbide, steel, ceramic and wood surfaces. Measure 1 3/4" long with 1/8" shanks. Choose from 30 individual styles and three sets of 10, 20 and 30 pieces. Always use with water or Lubricant/Thinner (see p. 145). All 1–1.5mm diameter points are fine (150 grit), and all 2–5mm diameter points are medium (120 grit). Max. operating speeds: 80,000rpm for 1–3mm dia; 60,000rpm for 3.5–4mm dia; 50,000rpm for 5mm dia.

								
Style	10A	15A	20A	25A	30A	35A	40A	50A
Dia. x L (mm)	1 x 8	1.5 x 8	2 x 8	2.5 x 8	3 x 10	3.5 x 10	4 x 10	5 x 10
Grit	150	150	120	120	120	120	120	120
Max. RPM	80,000	80,000	80,000	80,000	80,000	60,000	60,000	50,000
Item#	<b>226-1250</b>	<b>226-1251</b>	<b>226-1252</b>	<b>226-1253</b>	<b>226-1254</b>	<b>226-1255</b>	<b>226-1256</b>	<b>226-1257</b>
Each	<b>\$3.50</b>	<b>\$3.50</b>	<b>\$3.50</b>	<b>\$3.50</b>	<b>\$3.50</b>	<b>\$3.50</b>	<b>\$3.75</b>	<b>\$3.75</b>

								
Style	20B	30B	50B	15C	20C	25C	30C	35C
Dia. x L (mm)	2	3	5	1.5 x 8	2 x 8	2.5 x 10	3 x 10	3.5 x 10
Grit	120	120	120	150	120	120	120	120
Max. RPM	80,000	80,000	50,000	80,000	80,000	80,000	80,000	60,000
Item#	<b>226-1258</b>	<b>226-1259</b>	<b>226-1260</b>	<b>226-1261</b>	<b>226-1262</b>	<b>226-1263</b>	<b>226-1264</b>	<b>226-1265</b>
Each	<b>\$3.50</b>	<b>\$3.50</b>	<b>\$3.75</b>	<b>\$3.50</b>	<b>\$3.50</b>	<b>\$3.50</b>	<b>\$3.50</b>	<b>\$3.50</b>

							
Style	40C	50C	20F	30F	50F	20P	30P
Dia. x L (mm)	4 x 10	5 x 10	2 x 10	3 x 10	5 x 10	2 x 12	3 x 15
Grit	120	120	120	120	120	120	120
Max. RPM	60,000	50,000	80,000	80,000	50,000	80,000	80,000
Item#	<b>226-1266</b>	<b>226-1267</b>	<b>226-1275</b>	<b>226-1276</b>	<b>226-1277</b>	<b>226-1268</b>	<b>226-1269</b>
Each	<b>\$3.75</b>	<b>\$3.75</b>	<b>\$3.50</b>	<b>\$3.50</b>	<b>\$3.75</b>	<b>\$3.50</b>	<b>\$3.50</b>

							
Style	15R	20R	30R	30S	20T	30T	30V
Dia. x L (mm)	1.5 x 10	2 x 12	3 x 14	3 x 6	2 x 10	3 x 10	3 x 10
Grit	150	120	120	120	120	120	120
Max. RPM	80,000	80,000	80,000	80,000	80,000	80,000	80,000
Item#	<b>226-1270</b>	<b>226-1272</b>	<b>226-1273</b>	<b>226-1274</b>	<b>226-1278</b>	<b>226-1279</b>	<b>226-1280</b>
Each	<b>\$3.50</b>	<b>\$3.50</b>	<b>\$3.50</b>	<b>\$3.50</b>	<b>\$3.50</b>	<b>\$3.50</b>	<b>\$3.50</b>

**B Diamond Mounted Point Sets – 1/8" Shank**

Description	Item#	Each
<b>B. 10-Piece Set</b> (styles 10A, 20A, 30A, 30B, 15C, 25C, 20F, 20P, 30P, 20R)	<b>226-1281</b>	<b>\$31.50</b>
20-Piece Set (styles 10A, 15A, 20A, 25A, 30A, 35A, 20B, 30B, 15C, 20C, 25C, 30C, 20F, 30F, 20P, 30P, 15R, 20R, 30R, 20T)	<b>226-1282</b>	<b>63.00</b>
30-Piece Set (one of each style)	<b>226-1283</b>	<b>94.50</b>



# Diamond

## A Diamond Cutters – 3/32" Shank

Feature diamond particles electroplated onto stainless steel for unsurpassed quality and durability. Excellent for cleanup work on glass, ceramics and metals. Measure 1 3/4" long with 3/32" shanks. Choose from 24 individual sizes, two 12-piece sets and 20-piece master set (includes sizes asterisked below). Always use with water or Lubricant/Thinner (see p. 145). All are medium grit. Max. operating speed: 30,000rpm.

Dia. x L (mm)	2 x 1.5	2.7 x 1.5	4 x 1.5	6 x 2	1.5 x 4	2 x 8	3 x 4	7 x 12
Fine Item#	<b>226-1161*</b>	<b>226-1162*</b>	<b>226-1163*</b>	<b>226-1164*</b>	<b>226-1165</b>	<b>226-1166*</b>	<b>226-1167*</b>	<b>226-1168*</b>
Each	<b>\$3.75</b>	<b>\$3.75</b>	<b>\$4.20</b>	<b>\$5.49</b>	<b>\$3.75</b>	<b>\$3.75</b>	<b>\$4.45</b>	<b>\$10.51</b>

Dia. x L (mm)	6 x 7	1.5 x 10	2 x 12	3 x 12	3.5 x 6	1.5 x 10	0.9 x 4	2 x 5
Fine Item#	<b>226-1169*</b>	<b>226-1170*</b>	<b>226-1171*</b>	<b>226-1172*</b>	<b>226-1181*</b>	<b>226-1182</b>	<b>226-1183*</b>	<b>226-1184*</b>
Each	<b>\$7.87</b>	<b>\$3.75</b>	<b>\$4.08</b>	<b>\$4.45</b>	<b>\$5.49</b>	<b>\$3.75</b>	<b>\$3.75</b>	<b>\$3.75</b>

Dia. x L (mm)	6 x 10	2.5 x 7	2 x 7	1 x 1	2 x 2	3 x 3	4 x 4	4 x 0.8
Fine Item#	<b>226-1185*</b>	<b>226-1186*</b>	<b>226-1187</b>	<b>226-1188*</b>	<b>226-1189*</b>	<b>226-1190*</b>	<b>226-1191</b>	<b>226-1192*</b>
Each	<b>\$7.87</b>	<b>\$4.35</b>	<b>\$4.35</b>	<b>\$3.75</b>	<b>\$3.75</b>	<b>\$4.20</b>	<b>\$4.91</b>	<b>\$4.20</b>

## B



## B Diamond Cutter Sets – 3/32" Shank

Description	Item#	Each
B. 12-Piece Set #1 (#226-1161 thru #226-1172)	<b>226-1160</b>	<b>\$45.50</b>
12-Piece Set #2 (#226-1181 thru #226-1192)	<b>226-1180</b>	<b>43.70</b>

## C



## C Diamond Cutter Master Set – 3/32" Shank

Includes 20 sizes asterisked above and a convenient plastic holder.

Description	Item#	Each
20-Piece Master Set	<b>226-1159</b>	<b>\$79.00</b>

## D - N Ruby Carvers – 3/32" Shank

Long-lasting carvers with ruby crystals firmly bonded to 3/32" metal shanks for fast cutting. Dissipate heat very well and resist clogging. Outlast steel cutters. All fine grit. Max. operating speed: 35,000rpm.

Shape	Dia. x L (mm)	Item#	Each
D. Small Sphere	4.5 x 4.5	<b>128-4570</b>	<b>\$9.00</b>
E. Small Bud	3.5 x 4.5	<b>128-4575</b>	<b>9.00</b>
F. Medium Bud	4.5 x 6.5	<b>128-4565</b>	<b>9.00</b>
G. Cylinder	3.3 x 5.5	<b>128-4560</b>	<b>9.00</b>
H. Small Flame	3.3 x 8.0	<b>128-4580</b>	<b>9.00</b>
I. Medium Flame	4.0 x 10.0	<b>128-4583</b>	<b>9.00</b>
J. Large Sphere	7.5 x 7.5	<b>128-4590</b>	<b>11.00</b>
K. Pear	5.5 x 10.0	<b>128-4600</b>	<b>11.00</b>
L. Large Flame	6.5 x 12.6	<b>128-4605</b>	<b>11.00</b>
M. Inverted	8.5 x 12.0	<b>128-4610</b>	<b>11.00</b>
N. Tapered	8.5 x 16.0	<b>128-4615</b>	<b>11.00</b>

**A - C Polymond Diamond PSA Film**

For precise finishing of carbide steel, hard alloys, ceramic products, optical fiber or glass. Can even be used for finishing radius surfaces on steel molds. Made using revolutionary technology that mixes uniformly sized diamond grains and base material, unlike other polishing films that are only coated with grains. The result is a chemical-resistant, temperature-resistant (-200°C to 400°C) film that has good tensile strength and excellent cutting power. Can be used with any polishing oil. Cuts easily with scissors or a knife. Color-coded for easy grit identification. Available in 100 x 100mm sheets or in 21mm and 31mm diameter discs. (Use discs with appropriate 3mm shank holder listed below. Max. operating speed: 10,000 to 15,000rpm.)

A. Sheet	Color	Grit	Micron	Item#	Each
100 x 100mm	Green	3000	3-8	<b>107-5700</b>	<b>\$120.00</b>
100 x 100mm	Yellow Green	5000	0.5-3	<b>107-5701</b>	<b>120.00</b>
100 x 100mm	Yellow	10000	0-1	<b>107-5702</b>	<b>120.00</b>
B. Disc	Color	Grit	Micron	Item#	Each
21mm	Moss Green	280	65-75	<b>107-5740</b>	<b>\$6.95</b>
	Dark Mustard	400	40-60	<b>107-5741</b>	<b>6.95</b>
	Brown	600	30-40	<b>107-5742</b>	<b>6.95</b>
	Light Green	800	20-30	<b>107-5743</b>	<b>6.95</b>
	Black	1500	8-16	<b>107-5744</b>	<b>6.95</b>
31mm	Moss Green	280	65-75	<b>107-5760</b>	<b>12.95</b>
	Dark Mustard	400	40-60	<b>107-5761</b>	<b>12.95</b>
	Brown	600	30-40	<b>107-5762</b>	<b>12.95</b>
	Light Green	800	20-30	<b>107-5763</b>	<b>12.95</b>
	Black	1500	8-16	<b>107-5764</b>	<b>12.95</b>
C. Holder				Item#	Each
For 21mm discs				<b>510-0265</b>	<b>\$8.75</b>
For 31mm discs				<b>510-0270</b>	<b>8.75</b>



**A**



**B**



**C**

**D, E Diamond PSA Foil**

Consists of diamond abrasive particles electroplated onto very thin and flexible metal foil backed with pressure-sensitive adhesive. Cuts easily with scissors. Can be shaped, punched and bent to almost any configuration. Simply remove the paper backing and stick the foil to flat, curved or edged laps, or roll into a curve and position on a wheel. (Minimum wheel diameter for safe foil application is 5/16". Do not exceed 3,000rpm.) Available in a wide variety of grits for fast cutting of any metal and polishing of steels and carbides. No lubricant necessary.

Size	Grit	Item#	Each
<b>D.</b> 10 x 100mm (3/8" x 4")	100	<b>107-5800</b>	<b>\$24.90</b>
	200	<b>107-5805</b>	<b>24.90</b>
	300	<b>107-5810</b>	<b>24.90</b>
	400	<b>107-5815</b>	<b>24.90</b>
	600	<b>107-5820</b>	<b>24.90</b>
<b>E.</b> 50 x 100mm (2" x 4")	100	<b>107-5850</b>	<b>96.25</b>
	200	<b>107-5855</b>	<b>96.25</b>
	300	<b>107-5860</b>	<b>96.25</b>
	400	<b>107-5870</b>	<b>96.25</b>
	600	<b>107-5875</b>	<b>96.25</b>
	1000	<b>107-5880</b>	<b>96.25</b>



**D**



**E**

**A - C 3M™ Diamond Micro Finishing Film**

Choose from bands, discs, PSA strips and Hookit (Velcro-type) strips. Feature precision micron-graded diamond abrasive bonded onto tough, flexible 5-mil film backing. Can be used wet or dry. Cut faster than aluminum oxide and silicon carbide. Ideal for silver and gold and a great time-saver for harder metals such as stainless steel. Color-coded for easy grit identification. Use bands with drum arbors, discs with mandrel and strips with sticks (see below). Max. operating speeds: 20,000rpm for bands and 22,000rpm for discs.



**A**



**B**



**C**

Bands	Grade	Color	Mesh	Item#	Pkg. of 10
<b>A. 1/4" x 1/2" Bands</b>	E-74	Dk. Aqua	220	<b>101-1376</b>	<b>\$18.85</b>
	E-45	Yellow	320	<b>101-1377</b>	<b>17.50</b>
	E-30	Lt. Green	400	<b>101-1378</b>	<b>14.75</b>
	E-20	Lt. Brown	600	<b>101-1379</b>	<b>13.50</b>
1/2" x 1/2" Bands	E-74	Dk. Aqua	220	<b>101-1370</b>	<b>25.95</b>
	E-45	Yellow	320	<b>101-1371</b>	<b>24.95</b>
	E-30	Lt. Green	400	<b>101-1372</b>	<b>18.50</b>
	E-20	Lt. Brown	600	<b>101-1373</b>	<b>17.50</b>
Discs	Grade	Color	Mesh	Item#	Pkg. of 10
<b>B. 7/8" Discs</b>	E-74	Dk. Aqua	220	<b>101-1382</b>	<b>\$26.40</b>
	E-45	Yellow	320	<b>101-1383</b>	<b>22.35</b>
	E-30	Lt. Green	400	<b>101-1384</b>	<b>17.80</b>
	E-20	Lt. Brown	600	<b>101-1385</b>	<b>13.60</b>
Strips	Grade	Color	Mesh	Item#	Pkg. of 5
<b>C. 1" x 7" PSA Strips</b>	E-74	Dk. Aqua	220	<b>101-1389</b>	<b>\$5.75</b>
	E-45	Yellow	320	<b>101-1390</b>	<b>5.60</b>
	E-30	Lt. Green	400	<b>101-1391</b>	<b>5.70</b>
	E-20	Lt. Brown	600	<b>101-1392</b>	<b>4.45</b>
1" x 7" Hookit Strips	E-74	Dk. Aqua	220	<b>109-8400</b>	<b>7.95</b>
	E-45	Yellow	320	<b>109-8401</b>	<b>7.70</b>
	E-30	Lt. Green	400	<b>109-8402</b>	<b>7.85</b>
	E-20	Lt. Brown	600	<b>109-8403</b>	<b>6.15</b>
Description				Item#	Each
1/4" x 1/2" Drum Arbor, 1/8" shank				<b>840-1050</b>	<b>\$3.35</b>
1/2" x 1/2" Drum Arbor, 1/8" shank				<b>840-1060</b>	<b>3.35</b>
Disk Mandrel, 1/8" shank				<b>840-3150</b>	<b>1.35</b>
PSA Sticks (3)				<b>840-4405</b>	<b>6.00</b>
Hookit Sticks (3)				<b>840-4410</b>	<b>8.25</b>

**D 3M™ Diamond Micro Finishing Film Kits**

Money-saving introductory kits of diamond micro finishing film. Choose from two band kits, one disc kit and two strip kits. Each 21-piece band kit includes five bands of each grade (220, 320, 400 and 600), 1/8" shank drum arbor and plastic box. The 21-piece disc kit includes five discs of each grade (220, 320, 400 and 600), 1/8" shank mandrel and plastic box. The 8-piece PSA strip kit includes one PSA strip of each grade (220, 320, 400 and 600) and four PSA sticks. The 6-piece Hookit strip kit includes one Hookit strip of each grade (220, 320, 400 and 600) and two Hookit sticks.



**D**

Description	Item#	Each
21-Piece 1/4" x 1/2" Band Kit	<b>101-1380</b>	<b>\$34.15</b>
21-Piece 1/2" x 1/2" Band Kit	<b>101-1374</b>	<b>43.95</b>
21-Piece Disc Kit	<b>101-1388</b>	<b>39.65</b>
8-Piece PSA Strip Kit	<b>101-1395</b>	<b>10.65</b>
<b>D. 6-Piece Hookit Strip Kit</b>	<b>109-8405</b>	<b>10.05</b>



**A Diamond Cloth**

Fast-cutting, long-lasting cloth for touching up carbide, tool steels, glass and most other hard materials (not suitable for soft materials). Features precisely graded diamond grit evenly affixed to both sides. Provides maximum cutting action from every angle whether used by hand, on lapping sticks or in reciprocating or rotary power tools. Will not load. Can be cut to size with scissors and shaped to fit almost any configuration due to its excellent flexibility. Measures 60 x 60mm. Sold in several different color-coded grits. For maximum cutting efficiency, use with Gesswein Stoning and Lubricating Oil (see p. 31).

Color	Grit	Item#	Each
Green	140	<b>107-4941</b>	<b>\$25.95</b>
Blue	230	<b>107-4943</b>	<b>25.95</b>
Dk. Green	400	<b>107-4946</b>	<b>25.95</b>
Lt. Blue	600	<b>107-4947</b>	<b>25.95</b>
Red	1000	<b>107-4949</b>	<b>25.95</b>



**A**

**B 3M™ Flex Diamond Bands and Discs**

Incredibly durable, nonloading bands and discs for cleaning, shaping and precision pre-finishing. Coated with micron-graded diamond abrasive in a honeycomb pattern for fast cutting. Can be used wet or dry on both soft and hard metals. Produce optimal finishes with minimal metal removal. Won't gouge or catch. To polish any metal surface to a flawless mirror shine, use Flex Diamond prior to Imperial Film (see p. 66), then finish with rouge. Use bands with Drum Arbors (see p. 68), discs with Mandrels for 1/16" AH (see p. 131). Max. operating speed: 20,000rpm for bands; 22,000rpm for discs.

Description	Grit	Item#	Each
1/4" x 1/2" Band	120	<b>101-1310</b>	<b>\$3.35</b>
	220	<b>101-1315</b>	<b>3.35</b>
	400	<b>101-1320</b>	<b>2.95</b>
	800	<b>101-1325</b>	<b>2.95</b>
1/2" x 1/2" Band	60	<b>101-1330</b>	<b>4.95</b>
	120	<b>101-1335</b>	<b>4.65</b>
	220	<b>101-1340</b>	<b>4.05</b>
	400	<b>101-1345</b>	<b>3.90</b>
	800	<b>101-1350</b>	<b>3.90</b>
Description		Item#	Each
6-Piece 1/2" x 1/2" Band Kit (one band each of grits 60, 120, 220, 400, 800, 3/32" shank drum arbor, plastic case)		<b>101-1355</b>	<b>\$21.95</b>
26-Piece 7/8" Disc Kit (five discs each of grits 60, 120, 220, 400, 800, 3/32" shank mandrel, plastic case)		<b>101-1360</b>	<b>47.50</b>



**B**



**C Diamond-Impregnated Rubber Wheels and Points – 3/32" Shank**

These long-lasting wheels and points provide fast finishes on titanium and stainless steel. Made in three versatile sizes to access the tightest areas. Color-coded for grit identification. Available individually or in a specially priced nine-piece set that includes one of each shape and grit. All 3/32" shanks. Made in Germany. Max. operating speed: 5,000rpm.

Shape	Size	Medium Grit Green Item#	Fine Grit Gray Item#	Extra-Fine Grit Red Item#	Each
Point	4 x 13mm	<b>145-1322</b>	<b>145-1325</b>	<b>145-1328</b>	<b>\$8.85</b>
Wheel	11 x 2mm	<b>145-1321</b>	<b>145-1324</b>	<b>145-1327</b>	<b>8.85</b>
Wheel	11 x 4mm	<b>145-1323</b>	<b>145-1326</b>	<b>145-1329</b>	<b>15.60</b>
Description			Item#		Each
C. Set of all nine			<b>145-1320</b>		<b>\$94.50</b>



**C**

## A 3M™ Diamond QRS Discs

Aggressive, clean-cutting, long-lasting discs ideal for finishing or repair of hard-to-cut materials. Excellent for polishing dies and molds. Velcro-type backing makes changing discs easy: just pull off disc in use and press on another. Mount on QRS Roloc Disc Pads (see below). Discs are color-coded for easy grit identification.

**A**

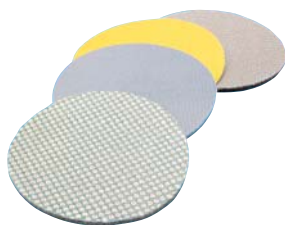

Dia.	Color	Grit	Micron	Item#	Pkg. of 2
1"	Green	60	250	<b>240-5006</b>	<b>\$7.55</b>
	Black	120	125	<b>240-5005</b>	<b>6.60</b>
	Red	200	74	<b>240-5004</b>	<b>5.75</b>
	Yellow	400	40	<b>240-5003</b>	<b>4.75</b>
	White	800	20	<b>240-5002</b>	<b>4.75</b>
	Blue	1800	10	<b>240-5001</b>	<b>4.75</b>
1½"	Green	60	250	<b>240-5012</b>	<b>16.90</b>
	Black	120	125	<b>240-5011</b>	<b>14.75</b>
	Red	200	74	<b>240-5010</b>	<b>12.85</b>
	Yellow	400	40	<b>240-5009</b>	<b>10.45</b>
	White	800	20	<b>240-5008</b>	<b>10.45</b>
	Blue	1800	10	<b>240-5007</b>	<b>10.45</b>

**B**



## B 3M™ Diamond QRS Roloc Disc Pads

Designed to hold 3M Diamond QRS Discs, these pads are made of neoprene foam, which provides a resilient base for the discs. Ideal for use on irregularly shaped and contoured surfaces. Must be used in conjunction with Roloc Disc Holders (see below).

Dia.	Max. RPM	Item#	Each
1"	30,000	<b>240-5013</b>	<b>\$3.65</b>
1½"	30,000	<b>240-5014</b>	<b>5.90</b>

## C 3M™ Roloc™ Disc Holders

Rubber Roloc Disc Holders are available in corresponding diameters and varying degrees of hardness for a variety of grinding and surface finishing applications. Holders are female threaded to receive any standard ¼"-20 thread mandrel or our #105-3110. For use with QRS Discs and Disc Pads (see above).

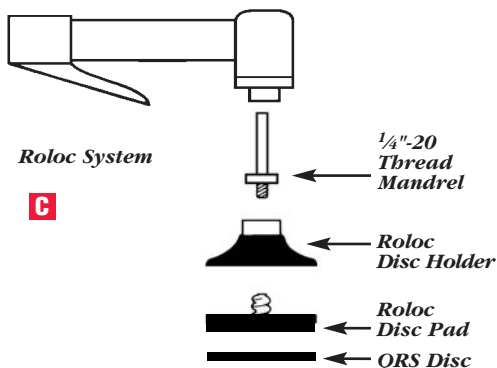

**C**

Dia.	Hardness	Max. RPM	Item#	Each
1"	Medium	30,000	<b>105-3070</b>	<b>\$9.50</b>
1½"	Hard	30,000	<b>105-3085</b>	<b>11.10</b>
	Medium	30,000	<b>105-3080</b>	<b>11.10</b>
	Soft	30,000	<b>105-3075</b>	<b>11.10</b>
Disc Holder Mandrel, ¼" Shank				<b>105-3110</b> <b>1.95</b>

## D 3M™ Diamond Hand Pads

Use for precision sharpening of all your blades and tools. Each pad has one cutting face that contains micron-graded diamonds. Open dot pattern provides aggressive cutting action and reduces loading. Flexible backing conforms to irregular surfaces. Pads are color-coded for easy grit identification. Cutting face measures 3¾"L x 2¼"W. Available individually or in a set of all six grits.



**D**

Color	Grit	Micron	Item#	Each
Green	60	250	<b>240-3060</b>	<b>\$22.99</b>
Black	120	125	<b>240-3061</b>	<b>18.75</b>
Red	200	74	<b>240-3062</b>	<b>15.25</b>
Yellow	400	40	<b>240-3063</b>	<b>12.05</b>
White	800	20	<b>240-3064</b>	<b>12.05</b>
Blue	1800	10	<b>240-3065</b>	<b>12.05</b>
Description			Item#	Each
<b>D. 6-Piece Set</b>				<b>240-3085</b> <b>\$107.90</b>

**A Copper Matrix Diamond Sheets**

Consist of diamond particles thoroughly mixed in a flexible copper alloy matrix for excellent dissipation of heat, allowing cutting with both sides and edges (sides are great for broad areas, edges for narrow slots). Boast uniform thicknesses and excellent diamond retention characteristics for many cutting and polishing applications on steel, carbide, ceramics and more.

Can be cut, punched, bent, soldered, brazed and glued. Use loose or attach to a handle. Shape to make hones and thin cut-off or slotting saws, or cut into a strip and roll into tubular shapes to make inexpensive and highly effective ring tools or core drills (thin-walled core drills provide increased cutting efficiency, longer life and minimal material loss). Measure 3" x 2". Diamond concentration is 50.

Grit	Particle Size (Microns)	Thickness	Item#	Each
Coarse (100/120)	100/120	0.012"	<b>107-5895</b>	<b>\$50.90</b>
Medium (500)	30/40	0.010"	<b>107-5890</b>	<b>46.75</b>
Fine (1200/1500)	8/12	0.008"	<b>107-5885</b>	<b>42.60</b>



**A**

**B, C Sintered Diamond Cut-Off Discs**

These discs easily cut carbon fiber, carbide, steels, acrylics and other hard-to-cut materials. Two smallest discs are sintered diamond throughout; largest disc is sintered diamond on outer edge only (approximately 1/8"). Each has 1/16" arbor hole. Max. operating speed: 20,000rpm.

Dia. x Thickness*	Item#	Each
<b>B. 7/8" x .007"</b>	<b>845-1080</b>	<b>\$29.95</b>
<b>C. 1 1/4" x .032"</b>	<b>845-1085</b>	<b>36.95</b>

\*Thickness of each disc may vary slightly.



**B**



**C**

**D NTMA Mold Finish Gauge**

Includes 29 specimen surfaces of various mold cavity finishes ranging from a #10 (3 micron, 8000 grit fine diamond polish) to a #290 (EDM RMAX 15). Includes four different ground surfaces and four EDM surfaces. Guidelines follow those of the NTMA (National Tooling & Machining Association). Molded black ABS plastic, hinged to protect sample surfaces. Folds to 10 1/2"L x 8"W.

Description	Item#	Each
NTMA Mold Finish Gauge	<b>811-0220</b>	<b>\$30.50</b>



**D**

**E Pocket-Size Mold Finish Gauge**

Includes nine specimen surfaces of finishes ranging from a #240 (silicon carbide) to a #1 (3 micron, 8000 grit fine diamond polish). Metalized plastic with storage case. Measures 4"L x 2"W x 1/8" thick.

Description	Item#	Each
Pocket-Size Mold Finish Gauge	<b>850-6090</b>	<b>\$77.90</b>



**E**

**F Pocket-Size S.P.I.® Mold Finish Gauge**

Take this handy guide anywhere. Flash chrome protectant ensures metal specimen surfaces will retain their exact finishes for years. Easy-to-read cross-reference table of S.P.I. and R.A. finishes makes for quick and accurate comparisons. Measures 5 7/8"L x 3 1/2"W.

Description	Item#	Each
Pocket-Size S.P.I. Mold Finish Gauge	<b>811-0225</b>	<b>\$189.95</b>



**F**



Plain cut



Double cut

## Gesswein® Solid Carbide Burs

Gesswein Solid Carbide Burs are made from laboratory-certified raw material. Most are machine-ground by CNC, producing geometric uniformity in shape and depth of flute. Controlled material selection and CNC manufacturing ensure high product consistency from order to order for dependable cutting action and much longer bur life. All Gesswein Solid Carbide Burs feature one-piece construction (head and shank made of one piece of carbide) unless otherwise indicated. Supplied in two fluting styles: plain cut, which provides aggressive cutting action for fast stock removal, leaving a slightly rough finish; and double cut, which cuts small chips for efficient stock removal, leaving a better finish than plain cut.

### Speed Recommendations (rpm):

Bur Cutting Diameter	1/16"	3/32"	1/8"	3/16"	1/4"
Stainless Steel	75,000	65,000	55,000	40,000	35,000
Other Common Materials	50,000	45,000	35,000	27,500	25,000

*These are suggested speeds only. Faster and slower speeds may be used for different materials.*

### Gesswein® Solid Carbide Burs – 1/4" Shank; 2" Overall

One-piece construction. 1/4" and 3/16" cutting diameters on 1/4" shanks. Can be resharpened. 6mm shanks and double cut available on special order. Quantity discount for orders of one item# only, not assorted.

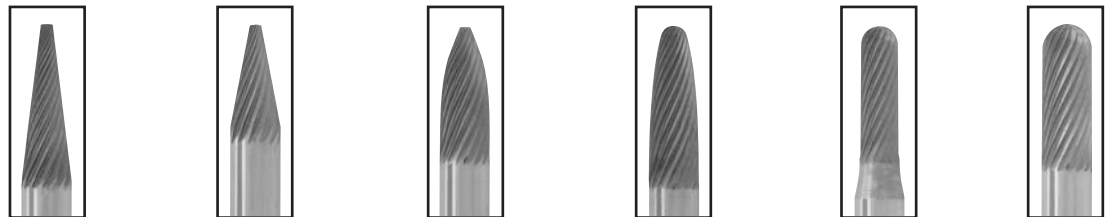

Cutting Diameter	1/4"	1/4"	1/4"	1/4"	3/16"	1/4"
Head Length	3/4"	1/2"	5/8"	5/8"	5/8"	1/8"
Included Angle	14°	22°	—	—	—	—
Plain Cut Item#	<b>129-2840</b>	<b>129-2140</b>	<b>129-2740</b>	<b>129-2640</b>	<b>129-2230</b>	<b>129-2240</b>
1-4 (each)	<b>\$14.15</b>	<b>\$12.80</b>	<b>\$13.25</b>	<b>\$13.25</b>	<b>\$12.65</b>	<b>\$12.65</b>
5+	<b>13.44</b>	<b>12.16</b>	<b>12.59</b>	<b>12.59</b>	<b>12.02</b>	<b>12.02</b>

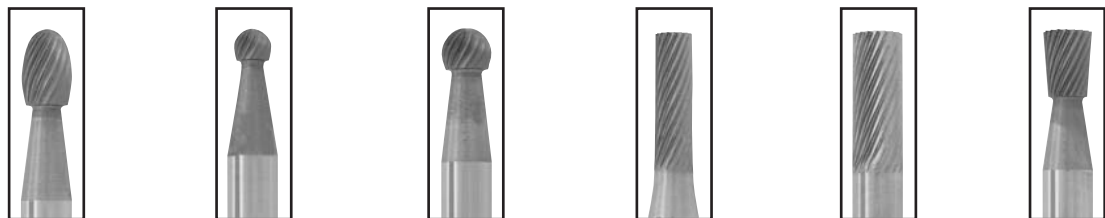

Cutting Diameter	1/4"	3/16"	1/4"	3/16"	1/4"	1/4"
Head Length	3/8"	1/8"	3/16"	5/8"	5/8"	5/16"
Included Angle	—	—	—	—	—	10°
Plain Cut Item#	<b>129-2440</b>	<b>129-2330</b>	<b>129-2340</b>	<b>129-2030</b>	<b>129-2040</b>	<b>129-2940</b>
1-4 (each)	<b>\$14.25</b>	<b>\$11.60</b>	<b>\$11.60</b>	<b>\$11.25</b>	<b>\$11.25</b>	<b>\$13.55</b>
5+	<b>13.54</b>	<b>11.02</b>	<b>11.02</b>	<b>10.69</b>	<b>10.69</b>	<b>12.87</b>



### A Gesswein® Solid Carbide Bur Set – 1/4" Shank; 2" Overall

Includes one each of the twelve burs listed above. Packaged in a sturdy hardwood box.

Description	Item#	Each
Plain Cut Set	<b>129-2000</b>	<b>\$150.40</b>

A



**Gesswein® Solid Carbide Burs – 3/16" Shank; 1 1/4" Overall**

One-piece construction. 3/16" cutting diameter on 3/16" shanks. Available in plain and double cut. Can be resharpened. Quantity discount for orders of one item# only, not assorted.

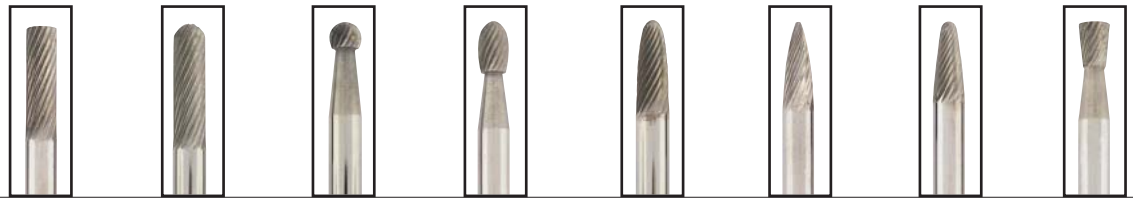

Cutting Diameter	3/16"	3/16"	3/16"	3/16"	3/16"	3/16"	3/16"	3/16"
Head Length	1/2"	1/2"	5/32"	9/32"	1/2"	1/2"	7/16"	1/4"
Plain Cut Item#	<b>129-1500</b>	<b>129-1510</b>	<b>129-1520</b>	<b>129-1530</b>	<b>129-1540</b>	<b>129-1550</b>	<b>129-1560</b>	<b>129-1570</b>
1-4 (each)	<b>\$11.50</b>	<b>\$11.50</b>	<b>\$11.50</b>	<b>\$11.50</b>	<b>\$11.50</b>	<b>\$11.50</b>	<b>\$11.50</b>	<b>\$11.50</b>
5+	<b>10.93</b>	<b>10.93</b>	<b>10.93</b>	<b>10.93</b>	<b>10.93</b>	<b>10.93</b>	<b>10.93</b>	<b>10.93</b>
Double Cut Item#	<b>129-1505</b>	<b>129-1515</b>	<b>129-1525</b>	<b>129-1535</b>	<b>129-1545</b>	<b>129-1555</b>	<b>129-1565</b>	<b>129-1575</b>
1-4 (each)	<b>\$12.50</b>	<b>\$12.50</b>	<b>\$12.50</b>	<b>\$12.50</b>	<b>\$12.50</b>	<b>\$12.50</b>	<b>\$12.50</b>	<b>\$12.50</b>
5+	<b>11.88</b>	<b>11.88</b>	<b>11.88</b>	<b>11.88</b>	<b>11.88</b>	<b>11.88</b>	<b>11.88</b>	<b>11.88</b>

**A Gesswein® Solid Carbide Bur Sets – 3/16" Shank; 2" Overall**

Each set includes one each of the eight respective burs listed above. Packaged in a sturdy hardwood box.

Description	Item#	Each
Plain Cut Set	<b>129-0950</b>	<b>\$98.95</b>
Double Cut Set	<b>129-0955</b>	<b>99.95</b>



**A**

**Gesswein® Solid Carbide Burs – 1/8" Shank; 3" Overall**

One-piece construction. 1/8" cutting diameter on 1/8" shanks. Available in plain and double cut. Can be resharpened.



Cutting Diameter	1/8"	1/8"	1/8"	1/8"	1/8"
Head Length	9/16"	1/8"	1/2"	1/2"	7/16"
Plain Cut Item#	<b>129-1210</b>	<b>129-1220</b>	<b>129-1230</b>	<b>129-1240</b>	<b>129-1250</b>
1-4 (each)	<b>\$8.50</b>	<b>\$8.50</b>	<b>\$8.50</b>	<b>\$8.50</b>	<b>\$8.50</b>
5+	<b>8.08</b>	<b>8.08</b>	<b>8.08</b>	<b>8.08</b>	<b>8.08</b>
Double Cut Item#	<b>129-1215</b>	<b>129-1225</b>	<b>129-1235</b>	<b>129-1245</b>	<b>129-1255</b>
1-4 (each)	<b>\$9.30</b>	<b>\$9.30</b>	<b>\$9.30</b>	<b>\$9.30</b>	<b>\$9.30</b>
5+	<b>8.84</b>	<b>8.84</b>	<b>8.84</b>	<b>8.84</b>	<b>8.84</b>

# Cutting Tools

## Gesswein® Solid Carbide Burs – 1/8" Shank; 1 1/2" Overall

One-piece construction. 3/16" and 5/32" cutting diameters on 1/8" shanks. Available in plain and double cut. Can be resharpened. 3mm shanks available on special order. Quantity discount for orders of one item# only, not assorted.

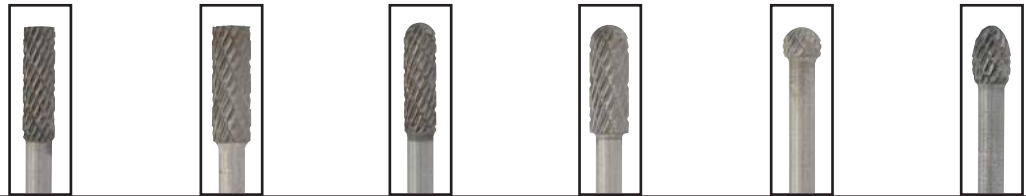

Cutting Diameter	5/32"	3/16"	5/32"	3/16"	3/16"	3/16"
Head Length	1/2"	1/2"	1/2"	1/2"	5/32"	9/32"
Plain Cut Item#	<b>129-1630</b>	<b>129-1640</b>	<b>129-1650</b>	<b>129-1660</b>	<b>129-1670</b>	<b>129-1680</b>
1-4 (each)	<b>\$15.30</b>	<b>\$15.30</b>	<b>\$15.30</b>	<b>\$15.30</b>	<b>\$15.30</b>	<b>\$15.30</b>
5+	<b>14.54</b>	<b>14.54</b>	<b>14.54</b>	<b>14.54</b>	<b>14.54</b>	<b>14.54</b>
Double Cut Item#	<b>129-1635</b>	<b>129-1645</b>	<b>129-1655</b>	<b>129-1665</b>	<b>129-1675</b>	<b>129-1685</b>
1-4 (each)	<b>\$16.95</b>	<b>\$16.95</b>	<b>\$16.95</b>	<b>\$16.95</b>	<b>\$16.95</b>	<b>\$16.95</b>
5+	<b>16.10</b>	<b>16.10</b>	<b>16.10</b>	<b>16.10</b>	<b>16.10</b>	<b>16.10</b>

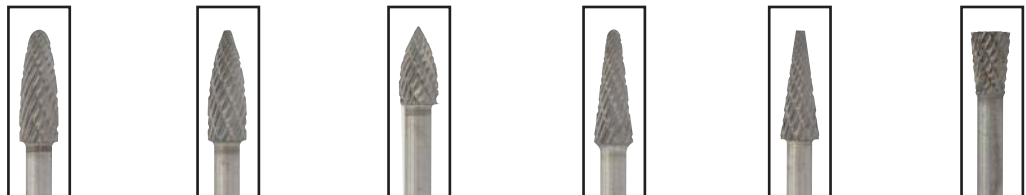

Cutting Diameter	3/16"	3/16"	3/16"	3/16"	3/16"	3/16"
Head Length	1/2"	1/2"	3/8"	1/2"	1/2"	1/4"
Included Angle	—	—	—	14°	16°	10°
Plain Cut Item#	<b>129-1690</b>	<b>129-1706</b>	<b>129-1710</b>	<b>129-1720</b>	<b>129-1730</b>	<b>129-1740</b>
1-4 (each)	<b>\$15.30</b>	<b>\$15.30</b>	<b>\$15.30</b>	<b>\$15.30</b>	<b>\$15.30</b>	<b>\$15.30</b>
5+	<b>14.54</b>	<b>14.54</b>	<b>14.54</b>	<b>14.54</b>	<b>14.54</b>	<b>14.54</b>
Double Cut Item#	<b>129-1695</b>	<b>129-1707</b>	<b>129-1715</b>	<b>129-1725</b>	<b>129-1735</b>	<b>129-1745</b>
1-4 (each)	<b>\$16.95</b>	<b>\$16.95</b>	<b>\$16.95</b>	<b>\$16.95</b>	<b>\$16.95</b>	<b>\$16.95</b>
5+	<b>16.10</b>	<b>16.10</b>	<b>16.10</b>	<b>16.10</b>	<b>16.10</b>	<b>16.10</b>



**A**

### **A** Gesswein® Solid Carbide Bur Sets – 1/8" Shank; 1 1/2" Overall

Each set includes one each of the 12 respective burs listed above. Packaged in a sturdy hardwood box.

Description	Item#	Each
Plain Cut Set	<b>129-0960</b>	<b>\$187.35</b>
Double Cut Set	<b>129-0965</b>	<b>202.95</b>



**B**

### **B** Gesswein® Lube-Stik

Use on any grinding, cutting, drilling, piercing or similar tool to speed up production and increase tool life. Lube-Stik reduces friction and heat buildup so that tools stay sharper, work faster and cut smoother. Easy to use—just run your tool in the soft lubricant. Supplied in a handy push-up dispenser tube.

Description	Item#	EACH Prices	
		1-9	10+
Lube-Stik	<b>816-2460</b>	<b>\$3.95</b>	<b>\$3.56</b>

## Gesswein® Solid Carbide Burs – 1/8" Shank; 1 1/2" Overall

One-piece construction. 1/16", 3/32" and 1/8" cutting diameters on 1/8" shanks. Can be resharpened. 3mm shanks available on special order. Quantity discount for orders of one item# only, not assorted.



Cutting Diameter	1/16"	3/32"	1/8"	3/32"	1/8"	3/32"	1/8"
Head Length	1/4"	7/16"	9/16"	7/16"	9/16"	3/32"	1/8"
Plain Cut Item#	<b>129-1010</b>	<b>129-1020*</b>	<b>129-1030*</b>	<b>129-1040</b>	<b>129-1050*</b>	<b>129-1060</b>	<b>129-1070*</b>
1-4 (each)	<b>\$5.30</b>	<b>\$5.30</b>	<b>\$5.30</b>	<b>\$5.30</b>	<b>\$5.30</b>	<b>\$5.30</b>	<b>\$5.30</b>
5+	<b>5.04</b>	<b>5.04</b>	<b>5.04</b>	<b>5.04</b>	<b>5.04</b>	<b>5.04</b>	<b>5.04</b>
Double Cut Item#	<b>129-1015</b>	<b>129-1025*</b>	<b>129-1035*</b>	<b>129-1045</b>	<b>129-1055*</b>	<b>129-1065</b>	<b>129-1075*</b>
1-4 (each)	<b>\$5.80</b>	<b>\$5.80</b>	<b>\$5.80</b>	<b>\$5.80</b>	<b>\$5.80</b>	<b>\$5.80</b>	<b>\$5.80</b>
5+	<b>5.51</b>	<b>5.51</b>	<b>5.51</b>	<b>5.51</b>	<b>5.51</b>	<b>5.51</b>	<b>5.51</b>



Cutting Diameter	1/8"	1/8"	1/8"	1/8"	1/8"	1/8"	1/8"
Head Length	7/32"	1/2"	1/4"	1/4"	1/4"	5/16"	3/8"
Plain Cut Item#	<b>129-1080*</b>	<b>129-1090*</b>	<b>129-1100*</b>	<b>129-1110*</b>	<b>129-1120*</b>	<b>129-1130</b>	<b>129-1140</b>
1-4 (each)	<b>\$5.30</b>	<b>\$5.30</b>	<b>\$5.30</b>	<b>\$5.30</b>	<b>\$5.30</b>	<b>\$5.30</b>	<b>\$5.30</b>
5+	<b>5.04</b>	<b>5.04</b>	<b>5.04</b>	<b>5.04</b>	<b>5.04</b>	<b>5.04</b>	<b>5.04</b>
Double Cut Item#	<b>129-1085*</b>	<b>129-1095*</b>	<b>129-1105*</b>	<b>129-1115*</b>	<b>129-1125*</b>	<b>129-1135</b>	<b>129-1145</b>
1-4 (each)	<b>\$5.80</b>	<b>\$5.80</b>	<b>\$5.80</b>	<b>\$5.80</b>	<b>\$5.80</b>	<b>\$5.80</b>	<b>\$5.80</b>
5+	<b>5.51</b>	<b>5.51</b>	<b>5.51</b>	<b>5.51</b>	<b>5.51</b>	<b>5.51</b>	<b>5.51</b>



Cutting Diameter	1/8"	1/8"	1/8"	1/8"	3/32"	1/8"
Head Length	7/16"	1 1/32"	5/8"	1/2"	1/8"	3/16"
Included Angle	14°	12°	7°	8°	10°	10°
Plain Cut Item#	<b>129-1150</b>	<b>129-1160</b>	<b>129-1170*</b>	<b>129-1180*</b>	<b>129-1190</b>	<b>129-1200*</b>
1-4 (each)	<b>\$5.30</b>	<b>\$5.30</b>	<b>\$5.30</b>	<b>\$5.30</b>	<b>\$5.30</b>	<b>\$5.30</b>
5+	<b>5.04</b>	<b>5.04</b>	<b>5.04</b>	<b>5.04</b>	<b>5.04</b>	<b>5.04</b>
Double Cut Item#	<b>129-1155</b>	<b>129-1165</b>	<b>129-1175*</b>	<b>129-1185*</b>	<b>129-1195</b>	<b>129-1205*</b>
1-4 (each)	<b>\$5.80</b>	<b>\$5.80</b>	<b>\$5.80</b>	<b>\$5.80</b>	<b>\$5.80</b>	<b>\$5.80</b>
5+	<b>5.51</b>	<b>5.51</b>	<b>5.51</b>	<b>5.51</b>	<b>5.51</b>	<b>5.51</b>

## A, B Gesswein® Solid Carbide Bur Sets – 1/8" Shank; 1 1/2" Overall

Each set includes one each of the 12 respective burs marked with asterisks above. Packaged in a sturdy hardwood box.

Description	Item#	Each
<b>A. Plain Cut Set</b>	<b>129-1000</b>	<b>\$65.10</b>
<b>B. Double Cut Set</b>	<b>129-1005</b>	<b>65.10</b>



# Cutting Tools

## Gesswein® Solid Carbide Burs – 3/32" Shank; 1 1/4" Overall

One-piece construction available in plain or double cut. 1/16" and 3/32" cutting diameters on 3/32" shanks. Can be resharpened. Quantity discount for orders of one item# only, not assorted.



Cutting Diameter	1/16"	3/32"	3/32"	3/32"	3/32"
Head Length	1/4"	3/8"	3/8"	3/32"	1/8"
Plain Cut Item#	<b>129-1400</b>	<b>129-1410</b>	<b>129-1420</b>	<b>129-1430</b>	<b>129-1440</b>
1-5 (each)	<b>\$7.95</b>	<b>\$7.95</b>	<b>\$7.95</b>	<b>\$7.95</b>	<b>\$7.95</b>
6+	<b>7.55</b>	<b>7.55</b>	<b>7.55</b>	<b>7.55</b>	<b>7.55</b>
Double Cut Item#	<b>129-1405</b>	<b>129-1415</b>	<b>129-1425</b>	<b>129-1435</b>	<b>129-1445</b>
1-5 (each)	<b>\$8.80</b>	<b>\$8.80</b>	<b>\$8.80</b>	<b>\$8.80</b>	<b>\$8.80</b>
6+	<b>8.36</b>	<b>8.36</b>	<b>8.36</b>	<b>8.36</b>	<b>8.36</b>



Cutting Diameter	3/32"	3/32"	3/32"	3/32"
Head Length	1/4"	1/4"	1/4"	1/8"
Plain Cut Item#	<b>129-1450</b>	<b>129-1460</b>	<b>129-1470</b>	<b>129-1480</b>
1-5 (each)	<b>\$7.95</b>	<b>\$7.95</b>	<b>\$7.95</b>	<b>\$7.95</b>
6+	<b>7.55</b>	<b>7.55</b>	<b>7.55</b>	<b>7.55</b>
Double Cut Item#	<b>129-1455</b>	<b>129-1465</b>	<b>129-1475</b>	<b>129-1485</b>
1-5 (each)	<b>\$8.80</b>	<b>\$8.80</b>	<b>\$8.80</b>	<b>\$8.80</b>
6+	<b>8.36</b>	<b>8.36</b>	<b>8.36</b>	<b>8.36</b>



### A Gesswein® Solid Carbide Bur Sets – 3/32" Shank; 1 1/4" Overall

Each set includes one each of the nine respective burs above. Packaged in a sturdy hardwood box.

Description	Item#	Each
Plain Cut Set	<b>129-0940</b>	<b>\$75.70</b>
Double Cut Set	<b>129-0945</b>	<b>75.70</b>

**A**

### B Carbide Cylinder Bur – 3/32" Shank

A very handy bur for deburring. Leaves behind a very smooth finish. Made of long-lasting carbide with an extra-fine cross cut. Head measures 1/4" dia. x 5/8"L. 3/32" shank.

Description	Item#	Each
Carbide Cylinder Bur	<b>129-0105</b>	<b>\$10.75</b>



**B**

### C Reducing Collets

Instantly converts your 1/8" or 3mm collet to hold a 3/32" tool shank. Simply slip reducing collet into collet on your rotary handpiece to use 3/32" shanked tools. Make sure both the reducing collet and the tool shank are fully inserted into the handpiece collet. Stainless steel.

Size	Item#	Each
1/8" to 3/32"	<b>816-1501</b>	<b>\$12.90</b>
3mm to 3/32"	<b>816-1504</b>	<b>12.90</b>



**C**



**Gesswein® Carbide Burs – 1/8" Shank; 1 1/2" Overall**

Carbide heads with 1/4" cutting diameter securely brazed on heat-treated 1/8" steel shanks. Can be resharpened. 3mm shanks available on special order. Quantity discount for orders of one item# only, not assorted.



Cutting Diameter	1/4"	1/4"	1/4"	1/4"	1/4"
Head Length	1/2"	3/16"	1/2"	1/2"	3/8"
Included angle	22°	—	—	—	—
Plain Cut Item#	<b>129-1820</b>	<b>129-1810</b>	<b>129-1800</b>	<b>129-1770</b>	<b>129-1790</b>
1-4 (each)	<b>\$9.50</b>	<b>\$9.50</b>	<b>\$9.50</b>	<b>\$9.50</b>	<b>\$9.50</b>
5+	<b>9.03</b>	<b>9.03</b>	<b>9.03</b>	<b>9.03</b>	<b>9.03</b>
Double Cut Item#	<b>129-1825</b>	<b>129-1815</b>	<b>129-1805</b>	<b>129-1775</b>	<b>129-1795</b>
1-4 (each)	<b>\$10.50</b>	<b>\$10.50</b>	<b>\$10.50</b>	<b>\$10.50</b>	<b>\$10.50</b>
5+	<b>9.98</b>	<b>9.98</b>	<b>9.98</b>	<b>9.98</b>	<b>9.98</b>



Cutting Diameter	1/4"	1/4"	1/4"	1/4"
Head Length	1/4"	3/16"	5/8"	1/4"
Included Angle	—	—	—	10°
Plain Cut Item#	<b>129-1780</b>	<b>129-1750</b>	<b>129-1760</b>	<b>129-1830</b>
1-4 (each)	<b>\$9.50</b>	<b>\$9.50</b>	<b>\$9.50</b>	<b>\$9.50</b>
5+	<b>9.03</b>	<b>9.03</b>	<b>9.03</b>	<b>9.03</b>
Double Cut Item#	<b>129-1785</b>	<b>129-1755</b>	<b>129-1765</b>	<b>129-1835</b>
1-4 (each)	<b>\$10.50</b>	<b>\$10.50</b>	<b>\$10.50</b>	<b>\$10.50</b>
5+	<b>9.98</b>	<b>9.98</b>	<b>9.98</b>	<b>9.98</b>



**A Gesswein® Carbide Bur Sets – 1/8" Shank; 1 1/2" Overall**

Each set includes one each of the nine respective burs listed above. Packaged in a sturdy hardwood box.

Description	Item#	Each
Plain Cut Set	<b>129-1700</b>	<b>\$94.20</b>
Double Cut Set	<b>129-1705</b>	<b>103.50</b>



## A - H Long-Shank Carbide Burs – 1/4" Shank, 6" Overall

Double-cut carbide burs with extra-long shanks for deburring hard-to-reach areas. Available in eight shapes in several sizes. Measure 6" long with 1/4" steel shanks. Can be easily reduced in length with a hacksaw.

	Head Size (Dia. x L)	Item#	Each
A. Cylinder	1/4" x 1/2"	129-1300	\$18.95
	3/8" x 3/4"	129-1301	26.80
	1/2" x 1"	129-1302	41.75
B. RE Cyl.	1/4" x 1/2"	129-1303	22.15
	3/8" x 3/4"	129-1304	29.80
	1/2" x 1"	129-1305	46.85
C. Ball	1/4" x 7/32"	129-1306	20.40
	3/8" x 5/16"	129-1307	24.50
	1/2" x 7/16"	129-1308	32.95
D. Oval	1/4" x 3/8"	129-1309	24.60
	3/8" x 5/8"	129-1310	29.80
	1/2" x 7/8"	129-1311	43.65

	Head Size (Dia. x L)	Item#	Each
E. RE Tree	1/4" x 1/2"	129-1312	\$23.10
	3/8" x 3/4"	129-1313	29.20
	1/2" x 1"	129-1314	42.95
F. PE Tree	1/4" x 1/2"	129-1315	23.10
	3/8" x 3/4"	129-1316	30.95
	1/2" x 1"	129-1317	42.40
G. Flame	5/16" x 3/4"	129-1318	30.65
	1/2" x 1 1/4"	129-1319	62.40
H. Taper	1/4" x 5/8"	129-1320	23.60
	3/8" x 1 1/16"	129-1321	37.25
	1/2" x 1 1/8"	129-1322	45.55

## I - N Nonferrous Carbide Burs – 1/4" Shank

Sometimes referred to as Aluma burs, nonferrous carbide burs feature an open, coarse cut ideal for use on soft, stringy materials such as aluminum. Also effective on hard woods, hard rubbers and plastics. Available in six shapes in several sizes. Have 1/4" shanks.

	Head Size (Dia. x L)	Overall Length	Item#	Each
I. Cylinder	1/4" x 3/4"	2"	129-1350	\$18.50
	3/8" x 3/4"	2 1/2"	129-1351	27.70
	1/2" x 1/2"	2 3/4"	129-1352	40.50
	5/8" x 1/2"	2 3/4"	129-1353	49.80
	3/4" x 1/2"	2 3/4"	129-1354	68.30
J. RE Cylinder	1/4" x 3/4"	2"	129-1355	20.65
	3/8" x 3/4"	2 1/2"	129-1356	27.70
	1/2" x 1"	2 3/4"	129-1357	40.50
	5/8" x 1"	2 3/4"	129-1358	61.80
K. Ball	3/4" x 1"	2 3/4"	129-1359	84.90
	1/4" x 7/32"	2"	129-1360	20.40
	3/8" x 5/16"	2 1/16"	129-1361	22.80
	1/2" x 7/16"	2 3/16"	129-1362	32.65
L. Oval	5/8" x 9/16"	2 5/16"	129-1363	58.95
	3/4" x 1 1/16"	2 7/16"	129-1364	99.75
	3/8" x 5/8"	2 3/8"	129-1365	29.95
	1/2" x 7/8"	2 5/8"	129-1366	36.90
	5/8" x 1"	2 3/4"	129-1367	66.50
M. Tree	3/4" x 1"	2 3/4"	129-1368	88.60
	1/4" x 3/4"	2 1/2"	129-1370	20.65
	3/8" x 3/4"	2 3/4"	129-1371	29.30
	1/2" x 1"	2 3/4"	129-1372	39.95
N. RE Taper	5/8" x 1"	3"	129-1373	58.95
	3/4" x 1"	3"	129-1374	80.95
	3/8" x 1 1/16"	3"	129-1375	37.55
	1/2" x 1 1/8"	3"	129-1376	51.75
	5/8" x 1 3/16"	3"	129-1377	82.95
	3/4" x 1 1/2"	3 3/8"	129-1378	109.95

**A - G S.S. White® Carbide Burs – 3/32" Shank**

High quality tungsten carbide burs securely brazed on heat-treated 3/32" steel shanks. Bur teeth are reinforced with extra carbide to eliminate premature chipping. Superior fluting improves cutting edges for pinpoint accuracy. All are end cut. Rigid inspection standards assure consistent quality. Cannot be resharpened. Made in USA. Five-piece minimum; please order in multiples of five. Quantity discount for orders of one item# only, not assorted.

**A Round**

Style	Diameter		Item#	EACH Prices	
	(mm)	(inches)		1-5	10+
W1	0.79	.031	<b>128-0010</b>	<b>\$2.15</b>	<b>\$1.83</b>
W2	0.99	.039	<b>128-0020</b>	<b>2.15</b>	<b>1.83</b>
W3	1.19	.047	<b>128-0030</b>	<b>2.15</b>	<b>1.83</b>
W4	1.40	.055	<b>128-0040</b>	<b>2.15</b>	<b>1.83</b>
W5	1.60	.063	<b>128-0050</b>	<b>2.15</b>	<b>1.83</b>
W6	1.80	.071	<b>128-0060</b>	<b>2.15</b>	<b>1.83</b>
W7	2.10	.083	<b>128-0070</b>	<b>2.15</b>	<b>1.83</b>
W8	2.31	.091	<b>128-0080</b>	<b>2.15</b>	<b>1.83</b>



**B Cylinder Square Cross Cut**

Style	Diameter		Item#	EACH Prices	
	(mm)	(inches)		1-5	10+
W557	0.99	.039	<b>128-5570</b>	<b>\$2.15</b>	<b>\$1.83</b>
W558	1.19	.047	<b>128-5580</b>	<b>2.15</b>	<b>1.83</b>
W559	1.40	.055	<b>128-5590</b>	<b>2.15</b>	<b>1.83</b>
W560	1.60	.063	<b>128-5600</b>	<b>2.15</b>	<b>1.83</b>



**C Wheel**

Style	Diameter		Item#	EACH Prices	
	(mm)	(inches)		1-5	10+
W14	1.19	.047	<b>128-0140</b>	<b>\$2.15</b>	<b>\$1.83</b>



**D Cone Square Cross Cut**

Style	Diameter		Item#	EACH Prices	
	(mm)	(inches)		1-5	10+
W700	0.56	.022	<b>128-7000</b>	<b>\$2.15</b>	<b>\$1.83</b>
W701	0.76	.030	<b>128-7010</b>	<b>2.15</b>	<b>1.83</b>
W702	1.11	.044	<b>128-7020</b>	<b>2.15</b>	<b>1.83</b>
W703	1.55	.061	<b>128-7030</b>	<b>2.15</b>	<b>1.83</b>

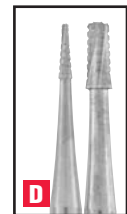

**E Inverted Cone**

Style	Diameter		Item#	EACH Prices	
	(mm)	(inches)		1-5	10+
W34	0.79	.031	<b>128-0340</b>	<b>\$2.15</b>	<b>\$1.83</b>
W35	0.99	.039	<b>128-0350</b>	<b>2.15</b>	<b>1.83</b>
W36	1.19	.047	<b>128-0360</b>	<b>2.15</b>	<b>1.83</b>
W37	1.40	.055	<b>128-0370</b>	<b>2.15</b>	<b>1.83</b>
W38	1.60	.063	<b>128-0380</b>	<b>2.15</b>	<b>1.83</b>



**F End**

Style	Diameter		Item#	EACH Prices	
	(mm)	(inches)		1-5	10+
W957	0.99	.039	<b>128-9570</b>	<b>\$2.15</b>	<b>\$1.83</b>

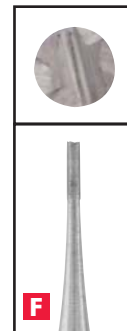

**G Cylinder Square**

Style	Diameter		Item#	EACH Prices	
	(mm)	(inches)		1-5	10+
W57	0.99	.039	<b>128-0570</b>	<b>\$2.15</b>	<b>\$1.83</b>
W59	1.40	.055	<b>128-0590</b>	<b>2.15</b>	<b>1.83</b>

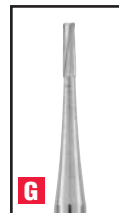

**H Wood Bur Boxes – For 3/32" Shanks**

Attractive sturdy hardwood boxes for bur or tools with 3/32" shanks.

Description	Item#	Each
200-Hole Box	<b>814-1200</b>	<b>\$25.75</b>
100-Hole Box	<b>814-1205</b>	<b>13.50</b>
36-Hole Box	<b>814-1210</b>	<b>7.95</b>



## A - K Super Carbide Burs – 3/32" Shank

Made of the finest grade carbide, accurately fluted and honed to sharp cutting edges. Bur heads are brazed onto 3/32" steel shanks. Super Carbide Burs have coarse tooth structure, are end cut and are designed to operate at very high speeds. Made in Germany. Quantity discount for orders of one item# only, not assorted.

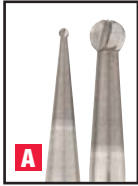

**A Round Fig 1**

Diameter		Item#	EACH Prices	
(mm)	(inches)		1-9	10+
0.70	.028	<b>126-0005</b>	<b>\$2.30</b>	<b>\$2.07</b>
0.80	.031	<b>126-0010</b>	<b>2.30</b>	<b>2.07</b>
1.00	.039	<b>126-0020</b>	<b>2.30</b>	<b>2.07</b>
1.20	.047	<b>126-0030</b>	<b>2.30</b>	<b>2.07</b>
1.40	.055	<b>126-0040</b>	<b>2.30</b>	<b>2.07</b>
1.60	.063	<b>126-0050</b>	<b>2.30</b>	<b>2.07</b>
1.80	.071	<b>126-0060</b>	<b>2.30</b>	<b>2.07</b>
2.30	.091	<b>126-0080</b>	<b>2.30</b>	<b>2.07</b>



**B Inverted Cone Fig 3**

Diameter		Item#	EACH Prices	
(mm)	(inches)		1-9	10+
0.80	.031	<b>126-0340</b>	<b>\$2.30</b>	<b>\$2.07</b>
1.00	.039	<b>126-0350</b>	<b>2.30</b>	<b>2.07</b>
1.20	.047	<b>126-0360</b>	<b>2.30</b>	<b>2.07</b>
1.40	.055	<b>126-0370</b>	<b>2.30</b>	<b>2.07</b>
1.60	.063	<b>126-0380</b>	<b>2.30</b>	<b>2.07</b>
1.80	.071	<b>126-0390</b>	<b>2.30</b>	<b>2.07</b>



**C Wheel Fig 2**

Diameter		Item#	EACH Prices	
(mm)	(inches)		1-9	10+
1.20	.047	<b>126-0140</b>	<b>\$2.30</b>	<b>\$2.07</b>



**D Cone Square Fig 17**

Diameter		Item#	EACH Prices	
(mm)	(inches)		1-9	10+
1.00	.039	<b>126-1700</b>	<b>\$2.30</b>	<b>\$2.07</b>
1.40	.055	<b>126-1710</b>	<b>2.30</b>	<b>2.07</b>



**E Cylinder Square Fig 15**

Diameter		Item#	EACH Prices	
(mm)	(inches)		1-9	10+
1.00	.039	<b>126-0570</b>	<b>\$2.30</b>	<b>\$2.07</b>
1.20	.047	<b>126-0580</b>	<b>2.30</b>	<b>2.07</b>



**F Cone Square Cross Cut Fig 23**

Diameter		Item#	EACH Prices	
(mm)	(inches)		1-9	10+
1.00	.039	<b>126-7000</b>	<b>\$2.30</b>	<b>\$2.07</b>
1.40	.055	<b>126-7010</b>	<b>2.30</b>	<b>2.07</b>
1.60	.063	<b>126-7020</b>	<b>2.30</b>	<b>2.07</b>
1.80	.071	<b>126-7030</b>	<b>2.30</b>	<b>2.07</b>



**G Cylinder Square Cross Cut Fig 21**

Diameter		Item#	EACH Prices	
(mm)	(inches)		1-9	10+
1.00	.039	<b>126-5570</b>	<b>\$2.30</b>	<b>\$2.07</b>
1.20	.047	<b>126-5580</b>	<b>2.30</b>	<b>2.07</b>
1.40	.055	<b>126-5590</b>	<b>2.30</b>	<b>2.07</b>
1.60	.063	<b>126-5600</b>	<b>2.30</b>	<b>2.07</b>
1.80	.071	<b>126-5610</b>	<b>2.30</b>	<b>2.07</b>



**F Cone Square Cross Cut Fig 23**

Diameter		Item#	EACH Prices	
(mm)	(inches)		1-9	10+
1.00	.039	<b>126-7000</b>	<b>\$2.30</b>	<b>\$2.07</b>
1.40	.055	<b>126-7010</b>	<b>2.30</b>	<b>2.07</b>
1.60	.063	<b>126-7020</b>	<b>2.30</b>	<b>2.07</b>
1.80	.071	<b>126-7030</b>	<b>2.30</b>	<b>2.07</b>



**I Cylinder Square Universal Fig 15U**

Diameter		Item#	EACH Prices	
(mm)	(inches)		1-9	10+
1.00	.039	<b>126-0575</b>	<b>\$2.30</b>	<b>\$2.07</b>
1.20	.047	<b>126-0585</b>	<b>2.30</b>	<b>2.07</b>



**H Cone Square Universal Fig 17U**

Diameter		Item#	EACH Prices	
(mm)	(inches)		1-9	10+
1.00	.039	<b>126-1705</b>	<b>\$2.30</b>	<b>\$2.07</b>
1.40	.055	<b>126-1715</b>	<b>2.30</b>	<b>2.07</b>



**K Cylinder Square Universal Cross Cut Fig 21U**

Diameter		Item#	EACH Prices	
(mm)	(inches)		1-9	10+
1.00	.039	<b>126-5575</b>	<b>\$2.30</b>	<b>\$2.07</b>
1.20	.047	<b>126-5585</b>	<b>2.30</b>	<b>2.07</b>
1.40	.055	<b>126-5595</b>	<b>2.30</b>	<b>2.07</b>
1.60	.063	<b>126-5605</b>	<b>2.30</b>	<b>2.07</b>
1.80	.071	<b>126-5615</b>	<b>2.30</b>	<b>2.07</b>



**J Cone Square Universal Cross Cut Fig 23U**

Diameter		Item#	EACH Prices	
(mm)	(inches)		1-9	10+
1.00	.039	<b>126-7005</b>	<b>\$2.30</b>	<b>\$2.07</b>
1.40	.055	<b>126-7015</b>	<b>2.30</b>	<b>2.07</b>
1.60	.063	<b>126-7025</b>	<b>2.30</b>	<b>2.07</b>
1.80	.071	<b>126-7035</b>	<b>2.30</b>	<b>2.07</b>



**A - F Diamond-Cut Carbide Burs – 3/32" Shank**

Individually hand cut with diamond wheels. Sizes 4-8 feature one-piece construction; sizes 9 and larger are securely brazed onto 3/32" steel shanks. All have fine teeth. Made in USA.



**A Round**

Size	Diameter		Item#	Each
	(mm)	(inches)		
4	1.50	.059	<b>125-5040</b>	<b>\$15.85</b>
5	1.70	.067	<b>125-5050</b>	<b>15.85</b>
6	1.90	.075	<b>125-5060</b>	<b>15.85</b>
7	2.10	.083	<b>125-5070</b>	<b>15.85</b>
8	2.30	.091	<b>125-5080</b>	<b>15.85</b>
9	2.50	.098	<b>125-5090</b>	<b>16.80</b>
10	2.70	.106	<b>125-5100</b>	<b>16.80</b>
11	2.90	.114	<b>125-5110</b>	<b>16.80</b>
12	3.10	.122	<b>125-5120</b>	<b>16.80</b>
13	3.30	.130	<b>125-5130</b>	<b>17.80</b>
14	3.50	.138	<b>125-5140</b>	<b>17.80</b>
16	4.00	.157	<b>125-5160</b>	<b>17.80</b>
18	4.50	.177	<b>125-5180</b>	<b>17.80</b>
20	5.00	.197	<b>125-5200</b>	<b>17.80</b>
24	5.60	.220	<b>125-5240</b>	<b>17.80</b>
26	6.30	.248	<b>125-5260</b>	<b>17.80</b>
28	7.20	.283	<b>125-5280</b>	<b>27.70</b>
30	8.00	.315	<b>125-5300</b>	<b>27.70</b>



**B 45° Hart**

Size	Diameter		Item#	Each
	(mm)	(inches)		
4	1.50	.059	<b>125-4040</b>	<b>\$15.85</b>
5	1.70	.067	<b>125-4050</b>	<b>15.85</b>
6	1.90	.075	<b>125-4060</b>	<b>15.85</b>
7	2.10	.083	<b>125-4070</b>	<b>15.85</b>
8	2.30	.091	<b>125-4080</b>	<b>15.85</b>
9	2.50	.098	<b>125-4090</b>	<b>16.80</b>
10	2.70	.106	<b>125-4100</b>	<b>16.80</b>
11	2.90	.114	<b>125-4110</b>	<b>16.80</b>
12	3.10	.122	<b>125-4120</b>	<b>16.80</b>
13	3.30	.130	<b>125-4130</b>	<b>17.80</b>
14	3.50	.138	<b>125-4140</b>	<b>17.80</b>
15	3.80	.150	<b>125-4150</b>	<b>17.80</b>
16	4.00	.157	<b>125-4160</b>	<b>17.80</b>
18	4.50	.177	<b>125-4180</b>	<b>17.80</b>
20	5.00	.197	<b>125-4200</b>	<b>17.80</b>
22	5.20	.205	<b>125-4220</b>	<b>17.80</b>
24	5.60	.220	<b>125-4240</b>	<b>17.80</b>
26	6.30	.248	<b>125-4260</b>	<b>17.80</b>
28	7.20	.283	<b>125-4280</b>	<b>27.70</b>
30	8.00	.315	<b>125-4300</b>	<b>27.70</b>



**C Bud**

Size	Diameter		Item#	Each
	(mm)	(inches)		
4	1.50	.059	<b>125-1040</b>	<b>\$15.85</b>
6	1.90	.075	<b>125-1060</b>	<b>15.85</b>
8	2.30	.091	<b>125-1080</b>	<b>15.85</b>
10	2.70	.106	<b>125-1100</b>	<b>16.80</b>
12	3.10	.122	<b>125-1120</b>	<b>16.80</b>
14	3.50	.138	<b>125-1140</b>	<b>17.80</b>
16	4.00	.157	<b>125-1160</b>	<b>17.80</b>
18	4.50	.177	<b>125-1180</b>	<b>17.80</b>
20	5.00	.197	<b>125-1200</b>	<b>17.80</b>
24	5.60	.220	<b>125-1240</b>	<b>17.80</b>
26	6.30	.248	<b>125-1260</b>	<b>17.80</b>
28	7.20	.283	<b>125-1280</b>	<b>27.70</b>
30	8.00	.315	<b>125-1300</b>	<b>27.70</b>



**D Cone**

Size	Diameter		Item#	Each
	(mm)	(inches)		
4	1.50	1.50	<b>125-2040</b>	<b>\$15.85</b>
6	1.90	.075	<b>125-2060</b>	<b>15.85</b>
8	2.30	.091	<b>125-2080</b>	<b>15.85</b>
10	2.70	.106	<b>125-2100</b>	<b>16.80</b>
12	3.10	.122	<b>125-2120</b>	<b>16.80</b>
14	3.50	.138	<b>125-2140</b>	<b>16.80</b>
16	4.00	.157	<b>125-2160</b>	<b>16.80</b>
18	4.50	.177	<b>125-2180</b>	<b>16.80</b>
20	5.00	.197	<b>125-2200</b>	<b>16.80</b>
24	5.60	.220	<b>125-2240</b>	<b>16.80</b>
26	6.30	.248	<b>125-2260</b>	<b>16.80</b>
28	7.20	.283	<b>125-2280</b>	<b>27.70</b>
30	8.00	.315	<b>125-2300</b>	<b>27.70</b>



**E Cylinder**

Size	Diameter		Item#	Each
	(mm)	(inches)		
26	6.30	.248	<b>125-3260</b>	<b>\$17.80</b>
30	8.00	.315	<b>125-3300</b>	<b>27.80</b>



**F Wheel**

Size	Diameter		Item#	Each
	(mm)	(inches)		
26	6.30	.248	<b>125-7260</b>	<b>\$17.80</b>
30	8.00	.315	<b>125-7300</b>	<b>27.70</b>



## A - H Friction Grip Carbide Burs – 1/16" Shank

Made from super-hard carbide securely brazed onto 1/16" steel shanks. They withstand extremely high speeds up to 350,000rpm. Designed to get into small spaces. All fit our NSK Presto Air Turbine (p. 112). See below for reducing collets from 1/8", 3mm or 3/32" to 1/16". Quantity discount for orders of one item# only, not assorted.



### A Round

Diameter (mm) (inches)	Item#	EACH Prices	
		1-4	5+
0.51 .020	<b>128-9700</b>	<b>\$2.40</b>	<b>\$2.28</b>
0.61 .024	<b>128-9705</b>	<b>2.40</b>	<b>2.28</b>
0.79 .031	<b>128-9710</b>	<b>2.40</b>	<b>2.28</b>
0.99 .039	<b>128-9715</b>	<b>2.40</b>	<b>2.28</b>
1.19 .047	<b>128-9720</b>	<b>2.40</b>	<b>2.28</b>
1.40 .055	<b>128-9725</b>	<b>2.40</b>	<b>2.28</b>
1.60 .063	<b>128-9730</b>	<b>2.40</b>	<b>2.28</b>
1.80 .071	<b>128-9735</b>	<b>2.40</b>	<b>2.28</b>
2.11 .083	<b>128-9740</b>	<b>2.40</b>	<b>2.28</b>
2.31 .091	<b>128-9745</b>	<b>2.40</b>	<b>2.28</b>



### B Cylinder Square

Diameter (mm) (inches)	Item#	EACH Prices	
		1-4	5+
0.79 .031	<b>128-9810</b>	<b>\$2.40</b>	<b>\$2.28</b>
0.99 .039	<b>128-9815</b>	<b>2.40</b>	<b>2.28</b>
1.19 .047	<b>128-9820</b>	<b>2.40</b>	<b>2.28</b>



### C Inverted Cone

Diameter (mm) (inches)	Item#	EACH Prices	
		1-4	5+
0.79 .031	<b>128-9755</b>	<b>\$2.40</b>	<b>\$2.28</b>
0.99 .039	<b>128-9760</b>	<b>2.40</b>	<b>2.28</b>
1.19 .047	<b>128-9765</b>	<b>2.40</b>	<b>2.28</b>
1.40 .055	<b>128-9770</b>	<b>2.40</b>	<b>2.28</b>
1.60 .063	<b>128-9775</b>	<b>2.40</b>	<b>2.28</b>
1.80 .071	<b>128-9780</b>	<b>2.40</b>	<b>2.28</b>



### D Cylinder Square Cross Cut

Diameter (mm) (inches)	Item#	EACH Prices	
		1-4	5+
0.79 .031	<b>128-9825</b>	<b>\$2.40</b>	<b>\$2.28</b>
0.99 .039	<b>128-9830</b>	<b>2.40</b>	<b>2.28</b>
1.19 .047	<b>128-9835</b>	<b>2.40</b>	<b>2.28</b>



### E Cone Square

Diameter (mm) (inches)	Item#	EACH Prices	
		1-4	5+
0.46 .018	<b>128-9840</b>	<b>\$2.40</b>	<b>\$2.28</b>
0.56 .022	<b>128-9845</b>	<b>2.40</b>	<b>2.28</b>
0.76 .030	<b>128-9850</b>	<b>2.40</b>	<b>2.28</b>



### F Cylinder Dome Cross Cut

Diameter (mm) (inches)	Item#	EACH Prices	
		1-4	5+
0.79 .031	<b>128-9870</b>	<b>\$2.40</b>	<b>\$2.28</b>
0.99 .039	<b>128-9875</b>	<b>2.40</b>	<b>2.28</b>
1.19 .047	<b>128-9880</b>	<b>2.40</b>	<b>2.28</b>



### G Cone Square Cross Cut

Diameter (mm) (inches)	Item#	EACH Prices	
		1-4	5+
0.46 .018	<b>128-9785</b>	<b>\$2.40</b>	<b>\$2.28</b>
0.56 .022	<b>128-9790</b>	<b>2.40</b>	<b>2.28</b>
0.76 .030	<b>128-9795</b>	<b>2.40</b>	<b>2.28</b>
1.12 .044	<b>128-9800</b>	<b>2.40</b>	<b>2.28</b>
1.55 .061	<b>128-9805</b>	<b>2.40</b>	<b>2.28</b>



### H Pear

Diameter (mm) (inches)	Item#	EACH Prices	
		1-4	5+
0.79 .031	<b>128-9855</b>	<b>\$2.40</b>	<b>\$2.28</b>
0.99 .039	<b>128-9860</b>	<b>2.40</b>	<b>2.28</b>
1.19 .047	<b>128-9865</b>	<b>2.40</b>	<b>2.28</b>



### I Reducing Collets

Instantly converts your 1/8", 3mm or 3/32" collet to hold a 1/16" tool shank. Simply slip reducing collet into collet on your rotary handpiece to use 1/16" shanked tools. Make sure both the reducing collet and the tool shank are fully inserted into the handpiece collet. Stainless steel.

Size	Item#	Each
1/8" to 1/16"	<b>816-1502</b>	<b>\$12.90</b>
3mm to 1/16"	<b>816-1505</b>	<b>12.90</b>
3/32" to 1/16"	<b>816-1503</b>	<b>12.90</b>

### High Speed Steel Burs – 3/32" Shank

Made of extremely rugged high-speed steel (HSS) to withstand heat buildup under the most extreme conditions. Perform faster and last longer than vanadium steel. Can be resharpened. All have 3/32" shanks. Made in USA. Quantity discount for orders of one item# only, not assorted.

#### A Round

Sizes	Diameter (mm)	Item#	EACH Prices	
			1-5	6+
1	0.90	123-8010	\$2.50	\$2.10
2	1.10	123-8020	2.50	2.10
3	1.30	123-8030	2.50	2.10
4	1.50	123-8040	2.50	2.10
5	1.70	123-8050	2.50	2.10
6	1.90	123-8060	2.50	2.10
7	2.10	123-8070	2.50	2.10
8	2.30	123-8080	2.50	2.10
9	2.50	123-8090	3.12	2.62
10	2.70	123-8100	3.12	2.62
11	2.90	123-8110	3.12	2.62
12	3.10	123-8120	3.12	2.62
13	3.30	123-8130	3.70	3.11
14	3.50	123-8140	3.70	3.11
15	3.80	123-8150	3.70	3.11
16	4.00	123-8160	3.70	3.11
17	4.30	123-8170	3.70	3.11
18	4.50	123-8180	3.70	3.11
19	4.70	123-8190	4.50	3.78
20	5.00	123-8200	4.50	3.78
22	5.20	123-8220	4.50	3.78
23	5.40	123-8230	4.50	3.78
24	5.60	123-8240	4.50	3.78
25	5.90	123-8250	4.50	3.78
26	6.30	123-8260	5.50	4.62
27	6.70	123-8270	5.50	4.62
28	7.20	123-8280	5.50	4.62
29	7.60	123-8290	5.50	4.62
30	8.00	123-8300	5.50	4.62
31	8.90	123-8310	6.70	5.63
32	9.60	123-8320	6.70	5.63
33	10.40	123-8330	7.30	6.13
34	11.10	123-8340	7.30	6.13



#### B Hart (45°)

Sizes	Diameter (mm)	Item#	EACH Prices	
			1-5	6+
2	1.10	123-5020	\$2.60	\$2.18
3	1.30	123-5030	2.60	2.18
4	1.50	123-5040	2.60	2.18
5	1.70	123-5050	2.60	2.18
6	1.90	123-5060	2.60	2.18
7	2.10	123-5070	2.60	2.18
8	2.30	123-5080	2.60	2.18
9	2.50	123-5090	3.65	3.07
10	2.70	123-5100	3.65	3.07
11	2.90	123-5110	3.65	3.07
12	3.10	123-5120	3.65	3.07
13	3.30	123-5130	4.40	3.70
14	3.50	123-5140	4.40	3.70
15	3.80	123-5150	4.40	3.70
16	4.00	123-5160	4.40	3.70
17	4.30	123-5170	4.40	3.70
18	4.50	123-5180	4.40	3.70
19	4.70	123-5190	4.99	4.19
20	5.00	123-5200	4.99	4.19
22	5.20	123-5220	4.99	4.19
24	5.60	123-5240	4.99	4.19
26	6.30	123-5260	5.50	4.62
28	7.20	123-5280	5.50	4.62
30	8.00	123-5300	5.50	4.62
34	11.10	123-5340	6.75	5.67



#### C Round HSS Bur Sets

The set of 18 burs contains sizes #1-18; the set of 25 burs contains sizes #1-26; the set of 29 burs contains sizes #1-30; the set of 33 burs contains sizes #1-34; the set of 36 burs contains sizes #1-12 (3 each). Each set includes an attractive wooden box.

Qty.	Item#	Set
18 burs	124-4111	\$55.25
25 burs	124-4112	78.55
29 burs	124-4113	96.25
33 burs	124-4114	108.12
36 burs	124-4115	93.39

#### D Hart (45°) HSS Bur Sets

The set of 17 burs contains sizes #2-18; the set of 14 burs contains sizes #2-28 (even only); the set of 24 burs contains sizes #2-30; the set of 33 burs contains sizes #2-12, (3 each). Each set includes an attractive wooden box.

Qty.	Item#	Set
17 burs	124-4551	\$58.35
14 burs	124-4552	57.28
24 burs	124-4553	87.40
33 burs	124-4554	96.60



# Cutting Tools

## High Speed Steel Burs, continued – 3/32" Shank



### A Bud

Sizes	Diameter (mm)	Item#	EACH Prices	
			1-5	6+
2	1.10	<b>123-1020</b>	<b>\$2.50</b>	<b>\$2.10</b>
3	1.30	<b>123-1030</b>	<b>2.50</b>	<b>2.10</b>
4	1.50	<b>123-1040</b>	<b>2.50</b>	<b>2.10</b>
5	1.70	<b>123-1050</b>	<b>2.50</b>	<b>2.10</b>
6	1.90	<b>123-1060</b>	<b>2.50</b>	<b>2.10</b>
7	2.10	<b>123-1070</b>	<b>2.50</b>	<b>2.10</b>
8	2.30	<b>123-1080</b>	<b>2.50</b>	<b>2.10</b>
9	2.50	<b>123-1090</b>	<b>3.12</b>	<b>2.62</b>
10	2.70	<b>123-1100</b>	<b>3.12</b>	<b>2.62</b>
11	2.90	<b>123-1110</b>	<b>3.12</b>	<b>2.62</b>
12	3.10	<b>123-1120</b>	<b>3.12</b>	<b>2.62</b>
13	3.30	<b>123-1130</b>	<b>3.70</b>	<b>3.11</b>
14	3.50	<b>123-1140</b>	<b>3.70</b>	<b>3.11</b>
16	4.00	<b>123-1160</b>	<b>3.70</b>	<b>3.11</b>
18	4.50	<b>123-1180</b>	<b>3.70</b>	<b>3.11</b>
20	5.00	<b>123-1200</b>	<b>5.80</b>	<b>4.87</b>
22	5.20	<b>123-1220</b>	<b>5.80</b>	<b>4.87</b>
24	5.60	<b>123-1240</b>	<b>5.80</b>	<b>4.87</b>
26	6.30	<b>123-1260</b>	<b>5.50</b>	<b>4.62</b>
28	7.20	<b>123-1280</b>	<b>5.50</b>	<b>4.62</b>
30	8.00	<b>123-1300</b>	<b>5.50</b>	<b>4.62</b>
32	9.60	<b>123-1320</b>	<b>6.70</b>	<b>5.63</b>
34	11.10	<b>123-1340</b>	<b>7.30</b>	<b>6.13</b>

### C Bud HSS Bur Sets

The set of 19 burs contains sizes #2-26; the set of 23 burs contains sizes #2-34. Each set includes an attractive wooden box.

Qty.	Item#	Set
19 burs	<b>124-4221</b>	<b>\$69.12</b>
23 burs	<b>124-4222</b>	<b>80.99</b>



### B Flame

Sizes	Diameter (mm)	Item#	EACH Prices	
			1-5	6+
2	1.1	<b>123-4020</b>	<b>\$2.88</b>	<b>\$2.42</b>
4	1.5	<b>123-4040</b>	<b>2.88</b>	<b>2.42</b>
6	1.9	<b>123-4060</b>	<b>2.88</b>	<b>2.42</b>
8	2.3	<b>123-4080</b>	<b>2.88</b>	<b>2.42</b>
10	2.7	<b>123-4100</b>	<b>3.65</b>	<b>3.07</b>
12	3.1	<b>123-4120</b>	<b>3.65</b>	<b>3.07</b>
14	3.5	<b>123-4140</b>	<b>4.40</b>	<b>3.70</b>
16	4.0	<b>123-4160</b>	<b>4.40</b>	<b>3.70</b>
18	4.5	<b>123-4180</b>	<b>4.40</b>	<b>3.70</b>
20	5.0	<b>123-4200</b>	<b>4.99</b>	<b>4.19</b>
22	5.2	<b>123-4220</b>	<b>4.99</b>	<b>4.19</b>
24	5.6	<b>123-4240</b>	<b>4.99</b>	<b>4.19</b>
26	6.3	<b>123-4260</b>	<b>4.99</b>	<b>4.19</b>
30	8.0	<b>123-4300</b>	<b>4.99</b>	<b>4.19</b>



### D Tree

Sizes	Diameter (mm)	Item#	EACH Prices	
			1-5	6+
5	1.7	<b>124-2050</b>	<b>\$2.88</b>	<b>\$2.42</b>
8	2.3	<b>124-2080</b>	<b>2.88</b>	<b>2.42</b>
13	3.3	<b>124-2130</b>	<b>4.40</b>	<b>3.70</b>
19	4.7	<b>124-2190</b>	<b>4.99</b>	<b>4.19</b>
26	6.3	<b>124-2260</b>	<b>5.50</b>	<b>4.62</b>
30	8.0	<b>124-2300</b>	<b>5.50</b>	<b>4.62</b>

### E Gesswein® Lube-Stik

Use on any grinding, cutting, drilling, piercing or similar tool to speed up production and increase tool life. Lube-Stik reduces friction and heat buildup so that tools stay sharper, work faster and cut smoother. Easy to use—just run your tool in the soft lubricant. Supplied in a handy push-up dispenser tube.

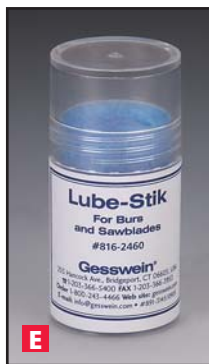

Description	Item#	EACH Prices	
		1-9	10+
Lube-Stik	<b>816-2460</b>	<b>\$3.95</b>	<b>\$3.56</b>



**A Reamer**

Sizes	Diameter (mm)	Item#	EACH Prices	
			1-5	6+
26	6.3	<b>123-7260</b>	<b>\$5.50</b>	<b>\$4.62</b>
30	8.0	<b>123-7300</b>	<b>5.50</b>	<b>4.62</b>
34	11.1	<b>123-7340</b>	<b>7.30</b>	<b>6.13</b>

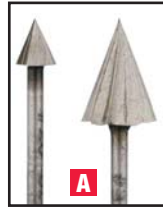

**B Inverted Cone**

Sizes	Diameter (mm)	Item#	EACH Prices	
			1-5	6+
5	1.7	<b>123-6050</b>	<b>\$2.88</b>	<b>\$2.42</b>
8	2.3	<b>123-6080</b>	<b>2.88</b>	<b>2.42</b>
13	3.3	<b>123-6130</b>	<b>4.40</b>	<b>3.70</b>
19	4.7	<b>123-6190</b>	<b>4.99</b>	<b>4.19</b>
26	6.3	<b>123-6260</b>	<b>5.50</b>	<b>4.62</b>
30	8.0	<b>123-6300</b>	<b>5.50</b>	<b>4.62</b>



**C Slim Reamer**

Sizes	Diameter (mm)	Item#	EACH Prices	
			1-5	6+
9	2.5	<b>124-1090</b>	<b>\$3.65</b>	<b>\$3.07</b>
13	3.3	<b>124-1130</b>	<b>4.40</b>	<b>3.70</b>
19	4.7	<b>124-1190</b>	<b>4.99</b>	<b>4.19</b>



**D Round Edge**

Sizes	Diameter (mm)	Item#	EACH Prices	
			1-5	6+
5	1.7	<b>123-9050</b>	<b>\$2.88</b>	<b>\$2.42</b>
8	2.3	<b>123-9080</b>	<b>2.88</b>	<b>2.42</b>
13	3.3	<b>123-9130</b>	<b>4.40</b>	<b>3.70</b>
16	4.0	<b>123-9160</b>	<b>4.40</b>	<b>3.70</b>
19	4.7	<b>123-9190</b>	<b>4.99</b>	<b>4.19</b>
26	6.3	<b>123-9260</b>	<b>5.50</b>	<b>4.62</b>
30	8.0	<b>123-9300</b>	<b>5.50</b>	<b>4.62</b>
34	11.1	<b>123-9340</b>	<b>7.30</b>	<b>6.13</b>

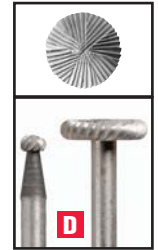

**E Cone**

Sizes	Diameter (mm)	Item#	EACH Prices	
			1-5	6+
2	1.10	<b>123-2020</b>	<b>\$2.50</b>	<b>\$2.10</b>
3	1.30	<b>123-2030</b>	<b>2.50</b>	<b>2.10</b>
4	1.50	<b>123-2040</b>	<b>2.50</b>	<b>2.10</b>
5	1.70	<b>123-2050</b>	<b>2.50</b>	<b>2.10</b>
6	1.90	<b>123-2060</b>	<b>2.50</b>	<b>2.10</b>
7	2.10	<b>123-2070</b>	<b>2.50</b>	<b>2.10</b>
8	2.30	<b>123-2080</b>	<b>2.50</b>	<b>2.10</b>
9	2.50	<b>123-2090</b>	<b>3.12</b>	<b>2.62</b>
10	2.70	<b>123-2100</b>	<b>3.12</b>	<b>2.62</b>
11	2.90	<b>123-2110</b>	<b>2.50</b>	<b>2.10</b>
12	3.10	<b>123-2120</b>	<b>2.50</b>	<b>2.10</b>
13	3.30	<b>123-2130</b>	<b>3.70</b>	<b>3.11</b>
14	3.50	<b>123-2140</b>	<b>3.70</b>	<b>3.11</b>
16	4.00	<b>123-2160</b>	<b>3.70</b>	<b>3.11</b>
18	4.50	<b>123-2180</b>	<b>3.70</b>	<b>3.11</b>
20	5.00	<b>123-2200</b>	<b>4.50</b>	<b>3.78</b>
22	5.20	<b>123-2220</b>	<b>4.50</b>	<b>3.78</b>
24	5.60	<b>123-2240</b>	<b>4.50</b>	<b>3.78</b>
26	6.30	<b>123-2260</b>	<b>5.50</b>	<b>4.62</b>
28	7.20	<b>123-2280</b>	<b>5.50</b>	<b>4.62</b>
30	8.00	<b>123-2300</b>	<b>5.50</b>	<b>4.62</b>
32	9.60	<b>123-2320</b>	<b>6.70</b>	<b>5.63</b>
34	11.10	<b>123-2340</b>	<b>7.30</b>	<b>6.13</b>



**F Cylinder**

Sizes	Diameter (mm)	Item#	EACH Prices	
			1-5	6+
5	1.7	<b>123-3050</b>	<b>\$2.88</b>	<b>\$2.42</b>
8	2.3	<b>123-3080</b>	<b>2.88</b>	<b>2.42</b>
13	3.3	<b>123-3130</b>	<b>4.40</b>	<b>3.70</b>
16	4.0	<b>123-3160</b>	<b>4.40</b>	<b>3.70</b>
19	4.7	<b>123-3190</b>	<b>4.99</b>	<b>4.19</b>
26	6.3	<b>123-3260</b>	<b>5.00</b>	<b>4.20</b>
30	8.0	<b>123-3300</b>	<b>5.00</b>	<b>4.20</b>
34	11.1	<b>123-3340</b>	<b>7.30</b>	<b>6.13</b>



**G Wheel**

Sizes	Diameter (mm)	Item#	EACH Prices	
			1-5	6+
5	1.7	<b>124-3050</b>	<b>\$2.88</b>	<b>\$2.42</b>
8	2.3	<b>124-3080</b>	<b>2.88</b>	<b>2.42</b>
13	3.3	<b>124-3130</b>	<b>4.40</b>	<b>3.70</b>
16	4.0	<b>124-3160</b>	<b>4.40</b>	<b>3.70</b>
19	4.7	<b>124-3190</b>	<b>4.99</b>	<b>4.19</b>
26	6.3	<b>124-3260</b>	<b>5.50</b>	<b>4.62</b>
30	8.0	<b>124-3300</b>	<b>5.50</b>	<b>4.62</b>
34	11.1	<b>124-3340</b>	<b>7.30</b>	<b>6.13</b>



**H Cone HSS Bur Sets**

The set of 19 burs contains sizes #2-26; the set of 23 burs contains sizes #2-34. Each set includes an attractive wooden box.

Qty.	Item#	Set
19 burs	<b>124-4331</b>	<b>\$69.12</b>
23 burs	<b>124-4332</b>	<b>80.99</b>



## Busch® Burs – 3/32" Shank

Made of tungsten vanadium steel for strength and durability. Teeth are precision-machined and uniformly spaced so cutting is accurate and smooth. Use a good lubricant (such as Gesswein Lube Stick, p. 178) to facilitate cutting and prolong tool life. The 3/32" shanks are approximately 1 3/4" long. Six-piece minimum unless otherwise indicated; please order in multiples of six. Quantity discount for orders of one item# only, not assorted. Made in Germany.



### A Busch® Round Fig 1

ISO#	Diameter (inches)	Item#	EACH Prices		
			6-66	72-138	144+
003	.0118	<b>122-2008</b>	<b>\$2.36</b>	<b>\$2.01</b>	<b>\$1.89</b>
–	.0138	<b>122-2007</b>	<b>1.18</b>	<b>1.00</b>	<b>.94</b>
004	.0157	<b>122-2006</b>	<b>1.18</b>	<b>1.00</b>	<b>.94</b>
005	.0197	<b>122-2005</b>	<b>.79</b>	<b>.67</b>	<b>.63</b>
006	.0236	<b>122-2004</b>	<b>.79</b>	<b>.67</b>	<b>.63</b>
007	.0276	<b>122-2003</b>	<b>.79</b>	<b>.67</b>	<b>.63</b>
008	.0315	<b>122-2002</b>	<b>.79</b>	<b>.67</b>	<b>.63</b>
009	.0354	<b>122-2001</b>	<b>.79</b>	<b>.67</b>	<b>.63</b>
–	.0382	<b>122-3005</b>	<b>.79</b>	<b>.67</b>	<b>.63</b>
010	.0393	<b>122-2010</b>	<b>.79</b>	<b>.67</b>	<b>.63</b>
011	.0433	<b>122-3015</b>	<b>.79</b>	<b>.67</b>	<b>.63</b>
012	.0472	<b>122-2020</b>	<b>.79</b>	<b>.67</b>	<b>.63</b>
013	.0512	<b>122-3025</b>	<b>.79</b>	<b>.67</b>	<b>.63</b>
014	.0551	<b>122-2030</b>	<b>.79</b>	<b>.67</b>	<b>.63</b>
–	.0559	<b>122-3035</b>	<b>.79</b>	<b>.67</b>	<b>.63</b>
015	.0591	<b>122-2040</b>	<b>.79</b>	<b>.67</b>	<b>.63</b>
–	.0622	<b>122-3045</b>	<b>.79</b>	<b>.67</b>	<b>.63</b>
016	.0630	<b>122-2050</b>	<b>.79</b>	<b>.67</b>	<b>.63</b>
017	.0669	<b>122-3055</b>	<b>.79</b>	<b>.67</b>	<b>.63</b>
018	.0709	<b>122-2060</b>	<b>.79</b>	<b>.67</b>	<b>.63</b>
019	.0748	<b>122-3065</b>	<b>.79</b>	<b>.67</b>	<b>.63</b>
020	.0787	<b>122-3066</b>	<b>.79</b>	<b>.67</b>	<b>.63</b>
021	.0827	<b>122-2070</b>	<b>.79</b>	<b>.67</b>	<b>.63</b>

ISO#	Diameter (inches)	Item#	EACH Prices		
			6-66	72-138	144+
022	.0866	<b>122-3075</b>	<b>\$7.79</b>	<b>\$6.67</b>	<b>\$6.63</b>
023	.0906	<b>122-2080</b>	<b>.79</b>	<b>.67</b>	<b>.63</b>
024	.0945	<b>122-3085</b>	<b>1.68</b>	<b>1.43</b>	<b>1.34</b>
025	.0984	<b>122-2090</b>	<b>1.68</b>	<b>1.43</b>	<b>1.34</b>
026	.1024	<b>122-3095</b>	<b>1.68</b>	<b>1.43</b>	<b>1.34</b>
027	.1063	<b>122-2100</b>	<b>1.68</b>	<b>1.43</b>	<b>1.34</b>
029	.1141	<b>122-2110</b>	<b>1.68</b>	<b>1.43</b>	<b>1.34</b>
031	.1220	<b>122-2120</b>	<b>2.46</b>	<b>2.09</b>	<b>1.97</b>
033	.1299	<b>122-2130</b>	<b>2.46</b>	<b>2.09</b>	<b>1.97</b>
035	.1378	<b>122-2140</b>	<b>2.46</b>	<b>2.09</b>	<b>1.97</b>
037	.1457	<b>122-2150</b>	<b>2.46</b>	<b>2.09</b>	<b>1.97</b>
040	.1575	<b>122-2160</b>	<b>3.08</b>	<b>2.62</b>	<b>2.46</b>
042	.1654	<b>122-2170</b>	<b>3.08</b>	<b>2.62</b>	<b>2.46</b>
045	.1772	<b>122-2180</b>	<b>3.08</b>	<b>2.62</b>	<b>2.46</b>
047	.1850	<b>122-2190</b>	<b>3.08</b>	<b>2.62</b>	<b>2.46</b>
050	.1968	<b>122-2200</b>	<b>3.08</b>	<b>2.62</b>	<b>2.46</b>
055	.2165	<b>122-2220</b>	<b>4.81</b>	<b>4.09</b>	<b>3.85</b>
060	.2362	<b>122-2240</b>	<b>4.81</b>	<b>4.09</b>	<b>3.85</b>
065	.2559	<b>122-2260</b>	<b>4.81</b>	<b>4.09</b>	<b>3.85</b>
070	.2756	<b>122-2280</b>	<b>4.81</b>	<b>4.09</b>	<b>3.85</b>
075	.2953	<b>122-2300</b>	<b>6.26</b>	<b>5.32</b>	<b>5.01</b>
080	.3149	<b>122-2320</b>	<b>6.26</b>	<b>5.32</b>	<b>5.01</b>
085	.3346	<b>122-2340</b>	<b>6.26</b>	<b>5.32</b>	<b>5.01</b>



### B Busch® Wax and Plastic Bur Fig 260a

Very coarse cut for carving wax or plastics.

ISO#	Diameter (inches)	Item#	EACH Prices		
			6-66	72-138	144+
018	.0709	<b>121-8170</b>	<b>\$3.20</b>	<b>\$2.72</b>	<b>\$2.56</b>
023	.0906	<b>121-8180</b>	<b>3.20</b>	<b>2.72</b>	<b>2.56</b>
031	.1220	<b>121-8190</b>	<b>6.02</b>	<b>5.12</b>	<b>4.82</b>
050	.1968	<b>121-8200</b>	<b>6.35</b>	<b>5.40</b>	<b>5.08</b>



### C Reducing Collets

Instantly converts your 1/8" or 3mm collet to hold a 3/32" tool shank. Simply slip reducing collet into collet on your rotary handpiece to use 3/32" shanked tools. Make sure both the reducing collet and the tool shank are fully inserted into the handpiece collet. Stainless steel.

Size	Item#	Each
1/8" to 3/32"	<b>816-1501</b>	<b>\$12.90</b>
3mm to 3/32"	<b>816-1504</b>	<b>12.90</b>

**A Busch® Wheel Fig 2**

ISO#	Diameter (inches)	Item#	EACH Prices		
			6-66	72-138	144+
007	.0276	<b>122-4003</b>	<b>\$.79</b>	<b>\$.67</b>	<b>\$.63</b>
008	.0315	<b>122-4002</b>	<b>.79</b>	<b>.67</b>	<b>.63</b>
009	.0354	<b>122-4001</b>	<b>.79</b>	<b>.67</b>	<b>.63</b>
010	.0393	<b>122-4010</b>	<b>.79</b>	<b>.67</b>	<b>.63</b>
012	.0472	<b>122-4020</b>	<b>.79</b>	<b>.67</b>	<b>.63</b>
014	.0551	<b>122-4030</b>	<b>.79</b>	<b>.67</b>	<b>.63</b>
016	.0630	<b>122-4050</b>	<b>.79</b>	<b>.67</b>	<b>.63</b>
018	.0709	<b>122-4060</b>	<b>.79</b>	<b>.67</b>	<b>.63</b>
021	.0827	<b>122-4070</b>	<b>.79</b>	<b>.67</b>	<b>.63</b>
023	.0906	<b>122-4080</b>	<b>.79</b>	<b>.67</b>	<b>.63</b>
025	.0984	<b>122-4090</b>	<b>1.68</b>	<b>1.43</b>	<b>1.34</b>
027	.1063	<b>122-4100</b>	<b>1.68</b>	<b>1.43</b>	<b>1.34</b>
029	.1141	<b>122-4110</b>	<b>1.68</b>	<b>1.43</b>	<b>1.34</b>
035	.1378	<b>122-4140</b>	<b>2.46</b>	<b>2.09</b>	<b>1.97</b>
040	.1575	<b>122-4160</b>	<b>3.08</b>	<b>2.62</b>	<b>2.46</b>
045	.1772	<b>122-4180</b>	<b>3.08</b>	<b>2.62</b>	<b>2.46</b>
050	.1968	<b>122-4200</b>	<b>3.08</b>	<b>2.62</b>	<b>2.46</b>

**C Busch® Pointed Fig 5**

ISO#	Diameter (inches)	Item#	EACH Prices		
			6-66	72-138	144+
009	.0354	<b>122-1001</b>	<b>\$.89</b>	<b>\$.76</b>	<b>\$.71</b>
010	.0393	<b>122-1010</b>	<b>.89</b>	<b>.76</b>	<b>.71</b>
012	.0472	<b>122-1020</b>	<b>.89</b>	<b>.76</b>	<b>.71</b>
014	.0551	<b>122-1030</b>	<b>.89</b>	<b>.76</b>	<b>.71</b>
016	.0630	<b>122-1050</b>	<b>.89</b>	<b>.76</b>	<b>.71</b>
018	.0709	<b>122-1060</b>	<b>.89</b>	<b>.76</b>	<b>.71</b>
021	.0827	<b>122-1070</b>	<b>.89</b>	<b>.76</b>	<b>.71</b>
023	.0906	<b>122-1080</b>	<b>.89</b>	<b>.76</b>	<b>.71</b>
025	.0984	<b>122-1090</b>	<b>1.85</b>	<b>1.57</b>	<b>1.48</b>
027	.1063	<b>122-1100</b>	<b>1.85</b>	<b>1.57</b>	<b>1.48</b>
029	.1141	<b>122-1110</b>	<b>1.85</b>	<b>1.57</b>	<b>1.48</b>
031	.1220	<b>122-1120</b>	<b>2.80</b>	<b>2.38</b>	<b>2.24</b>
033	.1299	<b>122-1130</b>	<b>2.80</b>	<b>2.38</b>	<b>2.24</b>
035	.1378	<b>122-1140</b>	<b>2.80</b>	<b>2.38</b>	<b>2.24</b>
037	.1457	<b>122-1150</b>	<b>2.80</b>	<b>2.38</b>	<b>2.24</b>
040	.1575	<b>122-1160</b>	<b>3.57</b>	<b>3.03</b>	<b>2.86</b>
045	.1772	<b>122-1180</b>	<b>3.57</b>	<b>3.03</b>	<b>2.86</b>
047	.1850	<b>122-1190</b>	<b>3.57</b>	<b>3.03</b>	<b>2.86</b>
050	.1968	<b>122-1200</b>	<b>3.57</b>	<b>3.03</b>	<b>2.86</b>

**B Busch® Bud Fig 6**

ISO#	Diameter (inches)	Item#	EACH Prices		
			6-66	72-138	144+
006	.0236	<b>121-0004</b>	<b>\$.89</b>	<b>\$.76</b>	<b>\$.71</b>
007	.0276	<b>121-0003</b>	<b>.89</b>	<b>.76</b>	<b>.71</b>
008	.0315	<b>121-0002</b>	<b>.89</b>	<b>.76</b>	<b>.71</b>
009	.0354	<b>121-0001</b>	<b>.89</b>	<b>.76</b>	<b>.71</b>
010	.0393	<b>121-0010</b>	<b>.89</b>	<b>.76</b>	<b>.71</b>
012	.0472	<b>121-0020</b>	<b>.89</b>	<b>.76</b>	<b>.71</b>
014	.0551	<b>121-0030</b>	<b>.89</b>	<b>.76</b>	<b>.71</b>
015	.0591	<b>121-0040</b>	<b>.89</b>	<b>.76</b>	<b>.71</b>
016	.0630	<b>121-0050</b>	<b>.89</b>	<b>.76</b>	<b>.71</b>
018	.0709	<b>121-0060</b>	<b>.89</b>	<b>.76</b>	<b>.71</b>
021	.0827	<b>121-0070</b>	<b>.89</b>	<b>.76</b>	<b>.71</b>
023	.0906	<b>121-0080</b>	<b>.89</b>	<b>.76</b>	<b>.71</b>
025	.0984	<b>121-0090</b>	<b>1.85</b>	<b>1.57</b>	<b>1.48</b>
027	.1063	<b>121-0100</b>	<b>1.85</b>	<b>1.57</b>	<b>1.48</b>
029	.1141	<b>121-0110</b>	<b>1.85</b>	<b>1.57</b>	<b>1.48</b>
031	.1220	<b>121-0120</b>	<b>2.80</b>	<b>2.38</b>	<b>2.24</b>
033	.1299	<b>121-0130</b>	<b>2.80</b>	<b>2.38</b>	<b>2.24</b>
035	.1378	<b>121-0140</b>	<b>2.80</b>	<b>2.38</b>	<b>2.24</b>
037	.1457	<b>121-0150</b>	<b>2.80</b>	<b>2.38</b>	<b>2.24</b>
040	.1575	<b>121-0160</b>	<b>3.57</b>	<b>3.03</b>	<b>2.86</b>
042	.1654	<b>121-0170</b>	<b>3.57</b>	<b>3.03</b>	<b>2.86</b>
045	.1772	<b>121-0180</b>	<b>3.57</b>	<b>3.03</b>	<b>2.86</b>
050	.1968	<b>121-0200</b>	<b>3.57</b>	<b>3.03</b>	<b>2.86</b>
ISO#	Diameter (inches)	Item#	EACH Prices		
			1-71	72-143	144+
080	.3149	<b>121-0320</b>	<b>\$5.42</b>	<b>\$4.61</b>	<b>\$4.34</b>
085	.3346	<b>121-0340</b>	<b>5.42</b>	<b>4.61</b>	<b>4.34</b>

**D Busch® Krause Fig 256**

ISO#	Diameter (inches)	Item#	EACH Prices		
			6-66	72-138	144+
010	.0393	<b>122-6010</b>	<b>\$2.75</b>	<b>\$2.34</b>	<b>\$2.20</b>
012	.0472	<b>122-6020</b>	<b>2.75</b>	<b>2.34</b>	<b>2.20</b>

**E Busch® Reamer Fig 115A**

ISO#	Diameter (inches)	Item#	EACH Prices		
			1-71	72-143	144+
018	.0709	<b>122-7130</b>	<b>\$6.11</b>	<b>\$5.19</b>	<b>\$4.89</b>
021	.0827	<b>122-7131</b>	<b>6.11</b>	<b>5.19</b>	<b>4.89</b>
023	.0906	<b>122-7132</b>	<b>6.11</b>	<b>5.19</b>	<b>4.89</b>



## Busch® Burs, continued – 3/32" Shank

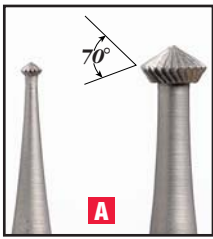

### A Busch® Hart (90°) Fig 156c

ISO#	Diameter (inches)	Item#	EACH Prices		
			6-66	72-138	144+
009	.0354	<b>121-9001</b>	<b>\$2.12</b>	<b>\$1.80</b>	<b>\$1.70</b>
–	.0382	<b>121-9305</b>	<b>2.12</b>	<b>1.80</b>	<b>1.70</b>
010	.0393	<b>121-9010</b>	<b>2.12</b>	<b>1.80</b>	<b>1.70</b>
011	.0433	<b>121-9315</b>	<b>2.12</b>	<b>1.80</b>	<b>1.70</b>
012	.0472	<b>121-9020</b>	<b>2.12</b>	<b>1.80</b>	<b>1.70</b>
013	.0512	<b>121-9325</b>	<b>2.12</b>	<b>1.80</b>	<b>1.70</b>
014	.0551	<b>121-9030</b>	<b>2.12</b>	<b>1.80</b>	<b>1.70</b>
–	.0559	<b>121-9335</b>	<b>2.12</b>	<b>1.80</b>	<b>1.70</b>
015	.0591	<b>121-9040</b>	<b>2.12</b>	<b>1.80</b>	<b>1.70</b>
–	.0622	<b>121-9345</b>	<b>2.12</b>	<b>1.80</b>	<b>1.70</b>
016	.0630	<b>121-9050</b>	<b>2.12</b>	<b>1.80</b>	<b>1.70</b>
017	.0669	<b>121-9355</b>	<b>2.12</b>	<b>1.80</b>	<b>1.70</b>
018	.0709	<b>121-9060</b>	<b>2.12</b>	<b>1.80</b>	<b>1.70</b>
020	.0787	<b>121-9365</b>	<b>2.12</b>	<b>1.80</b>	<b>1.70</b>
021	.0827	<b>121-9070</b>	<b>2.12</b>	<b>1.80</b>	<b>1.70</b>
022	.0866	<b>121-9375</b>	<b>2.12</b>	<b>1.80</b>	<b>1.70</b>
023	.0906	<b>121-9080</b>	<b>2.12</b>	<b>1.80</b>	<b>1.70</b>
025	.0984	<b>121-9090</b>	<b>3.08</b>	<b>2.62</b>	<b>2.46</b>
027	.1063	<b>121-9100</b>	<b>3.08</b>	<b>2.62</b>	<b>2.46</b>
029	.1141	<b>121-9110</b>	<b>3.08</b>	<b>2.62</b>	<b>2.46</b>
031	.1220	<b>121-9120</b>	<b>3.95</b>	<b>3.36</b>	<b>3.16</b>
033	.1299	<b>121-9130</b>	<b>3.95</b>	<b>3.36</b>	<b>3.16</b>
035	.1378	<b>121-9140</b>	<b>3.95</b>	<b>3.36</b>	<b>3.16</b>
037	.1457	<b>121-9150</b>	<b>3.95</b>	<b>3.36</b>	<b>3.16</b>
040	.1575	<b>121-9160</b>	<b>4.92</b>	<b>4.18</b>	<b>3.94</b>
042	.1654	<b>121-9170</b>	<b>4.92</b>	<b>4.18</b>	<b>3.94</b>
045	.1772	<b>121-9180</b>	<b>4.92</b>	<b>4.18</b>	<b>3.94</b>
047	.1850	<b>121-9190</b>	<b>4.92</b>	<b>4.18</b>	<b>3.94</b>
050	.1968	<b>121-9200</b>	<b>4.92</b>	<b>4.18</b>	<b>3.94</b>



### B Busch® Cylinder Square Fig 15

ISO#	Diameter (inches)	Item#	EACH Prices		
			6-66	72-138	144+
007	.0276	<b>121-2003</b>	<b>\$1.13</b>	<b>\$.96</b>	<b>\$.90</b>
008	.0315	<b>121-2002</b>	<b>1.13</b>	<b>.96</b>	<b>.90</b>
009	.0354	<b>121-2001</b>	<b>1.13</b>	<b>.96</b>	<b>.90</b>
010	.0393	<b>121-2010</b>	<b>1.13</b>	<b>.96</b>	<b>.90</b>
012	.0472	<b>121-2020</b>	<b>1.13</b>	<b>.96</b>	<b>.90</b>
014	.0551	<b>121-2030</b>	<b>1.13</b>	<b>.96</b>	<b>.90</b>
016	.0630	<b>121-2050</b>	<b>1.13</b>	<b>.96</b>	<b>.90</b>
018	.0709	<b>121-2060</b>	<b>1.13</b>	<b>.96</b>	<b>.90</b>
021	.0827	<b>121-2070</b>	<b>1.13</b>	<b>.96</b>	<b>.90</b>
023	.0906	<b>121-2080</b>	<b>1.13</b>	<b>.96</b>	<b>.90</b>
027	.1063	<b>121-2090</b>	<b>1.32</b>	<b>1.12</b>	<b>1.06</b>
031	.1220	<b>121-2120</b>	<b>2.81</b>	<b>2.39</b>	<b>2.25</b>



### C Busch® Cylinder Square Cross Cut Fig 21

ISO#	Diameter (inches)	Item#	EACH Prices		
			6-66	72-138	144+
008	.0315	<b>121-4002</b>	<b>\$1.13</b>	<b>\$.96</b>	<b>\$.90</b>
009	.0354	<b>121-4001</b>	<b>1.13</b>	<b>.96</b>	<b>.90</b>
010	.0393	<b>121-4010</b>	<b>1.13</b>	<b>.96</b>	<b>.90</b>
012	.0472	<b>121-4020</b>	<b>1.13</b>	<b>.96</b>	<b>.90</b>
014	.0551	<b>121-4030</b>	<b>1.13</b>	<b>.96</b>	<b>.90</b>
016	.0630	<b>121-4050</b>	<b>1.13</b>	<b>.96</b>	<b>.90</b>
018	.0709	<b>121-4060</b>	<b>1.13</b>	<b>.96</b>	<b>.90</b>
021	.0827	<b>121-4070</b>	<b>1.13</b>	<b>.96</b>	<b>.90</b>
023	.0906	<b>121-4080</b>	<b>1.13</b>	<b>.96</b>	<b>.90</b>
027	.1063	<b>121-4100</b>	<b>2.28</b>	<b>1.94</b>	<b>1.82</b>
031	.1220	<b>121-4120</b>	<b>2.81</b>	<b>2.39</b>	<b>2.25</b>



### D Busch® Hart (90°) Fig 156c, 12-Piece Bur Set

Includes one each of the following sizes: .0393, .0472, .0551, .0591, .0630, .0709, .0827, .0906, .0984, .1063, .1141 and .1220".

Description	Item#	Each
12-Piece Set	<b>121-9500</b>	<b>\$30.00</b>



### E Busch® Hart (90°) Fig 156c, 6-Piece Bur Set

Includes one each of the following sizes: .1299, .1378, .1457, .1575, .1654 and .1772".

Description	Item#	Each
6-Piece Set	<b>121-9550</b>	<b>\$26.55</b>



### F Reducing Collets

Instantly converts your 1/8" or 3mm collet to hold a 3/32" tool shank. Simply slip reducing collet into collet on your rotary handpiece to use 3/32" shanked tools. Make sure both the reducing collet and the tool shank are fully inserted into the handpiece collet. Stainless steel.

Size	Item#	Each
1/8" to 3/32"	<b>816-1501</b>	<b>\$12.90</b>
3mm to 3/32"	<b>816-1504</b>	<b>12.90</b>



**A Busch® Cone Square Fig 17**

ISO#	Diameter (inches)	Item#	EACH Prices		
			6-66	72-138	144+
007	.0276	<b>121-3003</b>	<b>\$1.13</b>	<b>\$.96</b>	<b>\$.90</b>
008	.0315	<b>121-3002</b>	<b>1.13</b>	<b>.96</b>	<b>.90</b>
009	.0354	<b>121-3001</b>	<b>1.13</b>	<b>.96</b>	<b>.90</b>
010	.0393	<b>121-3010</b>	<b>1.13</b>	<b>.96</b>	<b>.90</b>
012	.0472	<b>121-3020</b>	<b>1.13</b>	<b>.96</b>	<b>.90</b>
014	.0551	<b>121-3030</b>	<b>1.13</b>	<b>.96</b>	<b>.90</b>
016	.0630	<b>121-3050</b>	<b>1.13</b>	<b>.96</b>	<b>.90</b>
018	.0709	<b>121-3060</b>	<b>1.13</b>	<b>.96</b>	<b>.90</b>
021	.0827	<b>121-3070</b>	<b>1.13</b>	<b>.96</b>	<b>.90</b>

**B Busch® Cone Square Cross Cut Fig 23**

ISO#	Diameter (inches)	Item#	EACH Prices		
			6-66	72-138	144+
007	.0276	<b>121-5003</b>	<b>\$1.13</b>	<b>\$.96</b>	<b>\$.90</b>
008	.0315	<b>121-5002</b>	<b>1.13</b>	<b>.96</b>	<b>.90</b>
009	.0354	<b>121-5001</b>	<b>1.13</b>	<b>.96</b>	<b>.90</b>
010	.0393	<b>121-5010</b>	<b>1.13</b>	<b>.96</b>	<b>.90</b>
012	.0472	<b>121-5020</b>	<b>1.13</b>	<b>.96</b>	<b>.90</b>
014	.0551	<b>121-5030</b>	<b>1.13</b>	<b>.96</b>	<b>.90</b>
016	.0630	<b>121-5050</b>	<b>1.13</b>	<b>.96</b>	<b>.90</b>
018	.0709	<b>121-5060</b>	<b>1.13</b>	<b>.96</b>	<b>.90</b>
021	.0827	<b>121-5070</b>	<b>1.13</b>	<b>.96</b>	<b>.90</b>
023	.0906	<b>121-5080</b>	<b>1.13</b>	<b>.96</b>	<b>.90</b>
027	.1063	<b>121-5100</b>	<b>2.39</b>	<b>2.03</b>	<b>1.91</b>
031	.1220	<b>121-5120</b>	<b>2.81</b>	<b>2.39</b>	<b>2.25</b>



**C Busch® Inverted Cone Fig 3**

ISO#	Diameter (inches)	Item#	EACH Prices		
			6-66	72-138	144+
007	.0276	<b>122-0003</b>	<b>\$.79</b>	<b>\$.67</b>	<b>\$.63</b>
008	.0315	<b>122-0002</b>	<b>.79</b>	<b>.67</b>	<b>.63</b>
009	.0354	<b>122-0001</b>	<b>.79</b>	<b>.67</b>	<b>.63</b>
010	.0393	<b>122-0010</b>	<b>.79</b>	<b>.67</b>	<b>.63</b>
012	.0472	<b>122-0020</b>	<b>.79</b>	<b>.67</b>	<b>.63</b>
014	.0551	<b>122-0030</b>	<b>.79</b>	<b>.67</b>	<b>.63</b>
016	.0630	<b>122-0050</b>	<b>.79</b>	<b>.67</b>	<b>.63</b>
018	.0709	<b>122-0060</b>	<b>.79</b>	<b>.67</b>	<b>.63</b>
021	.0827	<b>122-0070</b>	<b>.79</b>	<b>.67</b>	<b>.63</b>
023	.0906	<b>122-0080</b>	<b>.79</b>	<b>.67</b>	<b>.63</b>
025	.0984	<b>122-0090</b>	<b>1.68</b>	<b>1.43</b>	<b>1.34</b>
027	.1063	<b>122-0100</b>	<b>1.68</b>	<b>1.43</b>	<b>1.34</b>
029	.1141	<b>122-0110</b>	<b>1.68</b>	<b>1.43</b>	<b>1.34</b>
031	.1220	<b>122-0120</b>	<b>2.46</b>	<b>2.09</b>	<b>1.97</b>
033	.1229	<b>122-0130</b>	<b>2.46</b>	<b>2.09</b>	<b>1.97</b>
037	.1457	<b>122-0150</b>	<b>2.46</b>	<b>2.09</b>	<b>1.97</b>
042	.1654	<b>122-0170</b>	<b>3.08</b>	<b>2.62</b>	<b>2.46</b>
045	.1772	<b>122-0180</b>	<b>3.08</b>	<b>2.62</b>	<b>2.46</b>

**D Busch® Mounted Saw Fig 231S**

ISO#	Diameter (inches)	Thickness (inches)	Item#	Each
123	.0906	.015	<b>121-8025</b>	<b>\$1.85</b>
050	.1968	.020	<b>121-8050</b>	<b>4.65</b>
100	.3937	.025	<b>121-8100</b>	<b>10.25</b>



**E Busch® Knife-Edge Router Fig 161**

ISO#	Diameter (inches)	Item#	Each
070	.2756	<b>121-7070</b>	<b>\$13.60</b>
100	.3937	<b>121-7100</b>	<b>19.15</b>
120	.4724	<b>121-7120</b>	<b>19.15</b>
140	.5512	<b>121-7140</b>	<b>22.15</b>

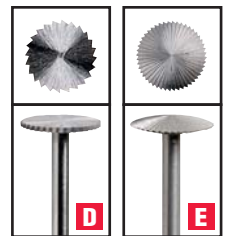

**F - P Typhoon® Carbide Burs – 1/8" Shank**

Unique burs with structurally aligned tungsten carbide teeth. Cut faster, leave a smoother finish than other types of tungsten carbide burs. Use on acrylic, hard rubber, fiberglass and wood. Available in two color-coded grits: red (coarse) and blue (fine). Have 1/8" shanks. Max. operating speed: 35,000rpm.

Shape	Dia. x L	Grit	Item#	Each
<b>F.</b> Small Sphere	5/16" x 5/16"	Coarse	<b>128-4500</b>	<b>\$15.00</b>
<b>G.</b> Long Tapered	3/16" x 3/4"	Coarse	<b>128-4515</b>	<b>15.00</b>
<b>H.</b> Ball Nose	5/16" x 1/2"	Coarse	<b>128-4530</b>	<b>15.00</b>
<b>I.</b> Dove Tail	7/16" x 1/2"	Coarse	<b>128-4545</b>	<b>16.00</b>
<b>J.</b> Small Sphere	5/16" x 5/16"	Fine	<b>128-4505</b>	<b>15.00</b>
<b>K.</b> Large Sphere	7/16" x 7/16"	Fine	<b>128-4510</b>	<b>15.00</b>
<b>L.</b> Long Tapered	3/16" x 3/4"	Fine	<b>128-4520</b>	<b>15.00</b>
<b>M.</b> Tapered	5/16" x 1/2"	Fine	<b>128-4525</b>	<b>15.00</b>
<b>N.</b> Ball Nose	5/16" x 1/2"	Fine	<b>128-4535</b>	<b>15.00</b>
<b>O.</b> Rotor Saw	7/16" x 3/16"	Fine	<b>128-4540</b>	<b>15.00</b>
<b>P.</b> Dove Tail	7/16" x 1/2"	Fine	<b>128-4550</b>	<b>16.00</b>

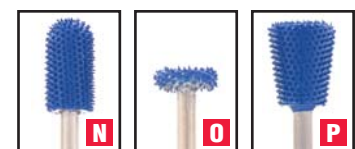



**A**

## **A Wooden Bur Boxes – For 3/32" Shanks**

Attractive, sturdy hardwood boxes for burs or tools with 3/32" shanks.

Description	Item#	Each
200-Hole Box	<b>814-1200</b>	<b>\$25.75</b>
100-Hole Box	<b>814-1205</b>	<b>13.50</b>
<b>A. 36-Hole Box</b>	<b>814-1210</b>	<b>7.95</b>



**B**

## **B Handy Block – For 3/32" or 1/8" Shanks**

A cured hardwood block with 88 holes for burs or tools with 3/32" or 1/8" shanks. Slanted design lets you see all tools at a glance. Stay-put rubber pads prevent sliding. Measures 6" x 4 1/2".

Description	Item#	Each
Handy Block	<b>814-1215</b>	<b>\$14.95</b>



**C**

## **C Rotating Bur Holders – For Burs and More**

Model 126 has 45 holes for burs with 1/16" shanks, 69 two-step holes for burs with 3/32" or 1/8" shanks and 12 holes for burs with 1/4" shanks. Model 114 has 114 holes for burs with 3/32" shanks and 2 3/4" dia. x 3"H center cup for hand tools. Model 112 has 92 holes for burs with 3/32" or 1/8" shanks, 13 holes for burs with 1/4" shanks, 7 holes for 1/16" to 5/32" drills and 2 3/4" dia. x 3"H center cup for hand tools. Rotate on ball bearings for smooth action. Measure 7" dia. x 4"H.

Description	Item#	Each
Model 126	<b>850-0004</b>	<b>\$14.95</b>
Model 114	<b>850-0005</b>	<b>14.95</b>
<b>C. Model 112</b>	<b>850-0006</b>	<b>14.95</b>



**D**

## **D Econo Rotating Bur Holder – For 3/32" Shanks**

Accepts up to 150 burs or tools with 3/32" shanks. Rotates to keep tools within easy reach. Measures 6" dia. x 4"H.

Description	Item#	Each
Econo Rotating Bur Holder	<b>124-4720</b>	<b>\$11.90</b>



**E**

## **E Bur Stand – For 1/8" Shanks**

Compact stand with 36 holes for burs or tools with 1/8" shanks. Fits in small areas. Made of clear hard plastic. Measures 2 3/4" x 2".

Description	Item#	Each
Bur Stand	<b>124-4705</b>	<b>\$9.00</b>

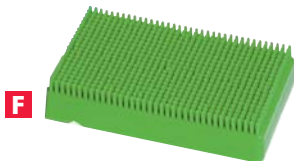

**F**

## **F Plastic Bur Holder – For 3/32" Shanks**

Accepts up to 100 burs or tools with 3/32" shanks. Supplied with tilt stand. Measures 5" x 3".

Description	Item#	EACH Prices	
		1-2	3+
Plastic Bur Holder	<b>840-0007</b>	<b>\$5.45</b>	<b>\$4.36</b>



**G**

## **G Interlocking Bur Block – For 3/32" Shanks**

Each accepts up to 40 burs or tools with 3/32" shanks. Features interlocking design for limitless storage capacity. Measures 4 1/4" x 3 1/8".

Description	Item#	EACH Prices	
		1-2	3+
Interlocking Bur Block	<b>124-4710</b>	<b>\$2.65</b>	<b>\$2.39</b>

## A Steel Reamers

Made of tempered steel, these five-sided cutting reamers are used for cleaning and reaming holes. Sizes are for diameters measured slightly below largest part of cutting edges.

Stubs	Diameter		Item#	EACH Prices	
	(mm)	(inches)		1-11	12+
30	3.226	0.127	<b>821-0300</b>	<b>\$5.60</b>	<b>\$4.76</b>
40	2.464	0.097	<b>821-0400</b>	<b>2.70</b>	<b>2.30</b>

Stubs	Diameter		Item#	EACH Prices	
	(mm)	(inches)		3-9	12+
50	1.753	0.069	<b>821-0500*</b>	<b>\$2.10</b>	<b>\$1.79</b>
60	0.990	0.039	<b>821-0600*</b>	<b>1.55</b>	<b>1.32</b>
70	0.685	0.027	<b>821-0700*</b>	<b>1.55</b>	<b>1.32</b>

Description	Item#	Each
Set of 12 (sizes 15, 25, 30, 35, 40, 45, 48, 51, 54, 56, 65 and 70)	<b>821-1157</b>	<b>\$29.40</b>
Set of 12 (sizes 30, 35, 40, 45, 48, 52, 54, 55, 58, 62, 65 and 70)	<b>821-1307</b>	<b>29.40</b>

\*Three-piece minimum; please order in multiples of three.

## C Busch® Twist Drill Fig 77 – 3/32" Shank

Made of tungsten vanadium steel. Individual sizes packaged six to a box.

ISO#	Diameter		Item#	EACH Prices		
	(mm)	(inches)		6-66	72-138	144+
005	0.50	.0197	<b>122-7005</b>	<b>\$2.09</b>	<b>\$1.78</b>	<b>\$1.67</b>
006*	0.60	.0236	<b>122-7006</b>	<b>2.09</b>	<b>1.78</b>	<b>1.67</b>
007*	0.70	.0276	<b>122-7007</b>	<b>2.09</b>	<b>1.78</b>	<b>1.67</b>
008*	0.80	.0315	<b>122-7008</b>	<b>2.09</b>	<b>1.78</b>	<b>1.67</b>
009*	0.90	.0354	<b>122-7009</b>	<b>2.09</b>	<b>1.78</b>	<b>1.67</b>
010*	1.00	.0393	<b>122-7010</b>	<b>2.09</b>	<b>1.78</b>	<b>1.67</b>
011	1.10	.0433	<b>122-7011</b>	<b>2.09</b>	<b>1.78</b>	<b>1.67</b>
012*	1.20	.0472	<b>122-7012</b>	<b>2.09</b>	<b>1.78</b>	<b>1.67</b>
014*	1.40	.0551	<b>122-7014</b>	<b>2.09</b>	<b>1.78</b>	<b>1.67</b>
015*	1.50	.0591	<b>122-7015</b>	<b>2.09</b>	<b>1.78</b>	<b>1.67</b>
016*	1.60	.0630	<b>122-7016</b>	<b>2.09</b>	<b>1.78</b>	<b>1.67</b>
017	1.70	.0669	<b>122-7017</b>	<b>2.09</b>	<b>1.78</b>	<b>1.67</b>
018*	1.80	.0709	<b>122-7018</b>	<b>2.09</b>	<b>1.78</b>	<b>1.67</b>
019*	1.90	.0748	<b>122-7019</b>	<b>2.09</b>	<b>1.78</b>	<b>1.67</b>
021*	2.10	.0827	<b>122-7021</b>	<b>2.09</b>	<b>1.78</b>	<b>1.67</b>
023	2.30	.0906	<b>122-7023</b>	<b>2.09</b>	<b>1.78</b>	<b>1.67</b>

Six-piece minimum; please order in multiples of six.

## E Busch® Twist Drill Fig 77 Set

Includes one each of the asterisked tungsten vanadium steel drills above.

Description	Item#	Each
12-Piece Set	<b>122-7030</b>	<b>\$25.05</b>

## F SUPRA® Twist Drill Set

Includes one each of the asterisked tungsten vanadium steel drills above.

Description	Item#	Each
12-Piece Set	<b>155-2319</b>	<b>\$21.00</b>

## B Busch® High-Speed Twist Drill – 3/32" Shank

These high-speed steel drills last longer than tungsten vanadium steel drills.

ISO#	Diameter		Item#	EACH Prices		
	(mm)	(inches)		1-71	72-143	144+
005	0.50	.0197	<b>122-6992</b>	<b>\$5.20</b>	<b>\$4.42</b>	<b>\$4.16</b>
006	0.60	.0236	<b>122-6993</b>	<b>5.20</b>	<b>4.42</b>	<b>4.16</b>
007	0.70	.0276	<b>122-6994</b>	<b>5.20</b>	<b>4.42</b>	<b>4.16</b>
008	0.80	.0315	<b>122-6995</b>	<b>5.20</b>	<b>4.42</b>	<b>4.16</b>
009	0.90	.0354	<b>122-6996</b>	<b>5.20</b>	<b>4.42</b>	<b>4.16</b>
010	1.00	.0393	<b>122-6997</b>	<b>5.20</b>	<b>4.42</b>	<b>4.16</b>
011	1.10	.0433	<b>122-6998</b>	<b>5.20</b>	<b>4.42</b>	<b>4.16</b>
012	1.20	.0472	<b>122-6999</b>	<b>5.20</b>	<b>4.42</b>	<b>4.16</b>
013	1.30	.0511	<b>122-7000</b>	<b>5.20</b>	<b>4.42</b>	<b>4.16</b>
014	1.40	.0551	<b>122-7001</b>	<b>5.20</b>	<b>4.42</b>	<b>4.16</b>
015	1.50	.0591	<b>122-7002</b>	<b>5.20</b>	<b>4.42</b>	<b>4.16</b>
016	1.60	.0630	<b>122-7003</b>	<b>5.20</b>	<b>4.42</b>	<b>4.16</b>

## D SUPRA® Twist Drill – 3/32" Shank

Made of tungsten vanadium steel. Individual sizes packaged six to a box.

ISO#	Diameter		Item#	EACH Prices		
	(mm)	(inches)		6-66	72-138	144+
005	0.50	.0197	<b>155-2300</b>	<b>\$1.95</b>	<b>\$1.66</b>	<b>\$1.56</b>
006*	0.60	.0236	<b>155-2301</b>	<b>1.95</b>	<b>1.66</b>	<b>1.56</b>
007*	0.70	.0276	<b>155-2302</b>	<b>1.95</b>	<b>1.66</b>	<b>1.56</b>
008*	0.80	.0315	<b>155-2303</b>	<b>1.95</b>	<b>1.66</b>	<b>1.56</b>
009*	0.90	.0354	<b>155-2304</b>	<b>1.95</b>	<b>1.66</b>	<b>1.56</b>
010*	1.00	.0393	<b>155-2305</b>	<b>1.95</b>	<b>1.66</b>	<b>1.56</b>
011	1.10	.0433	<b>155-2306</b>	<b>1.95</b>	<b>1.66</b>	<b>1.56</b>
012*	1.20	.0472	<b>155-2307</b>	<b>1.95</b>	<b>1.66</b>	<b>1.56</b>
014*	1.40	.0551	<b>155-2309</b>	<b>1.95</b>	<b>1.66</b>	<b>1.56</b>
015*	1.50	.0591	<b>155-2310</b>	<b>1.95</b>	<b>1.66</b>	<b>1.56</b>
016*	1.60	.0630	<b>155-2311</b>	<b>1.95</b>	<b>1.66</b>	<b>1.56</b>
017	1.70	.0669	<b>155-2312</b>	<b>1.95</b>	<b>1.66</b>	<b>1.56</b>
018*	1.80	.0709	<b>155-2313</b>	<b>1.95</b>	<b>1.66</b>	<b>1.56</b>
019	1.90	.0748	<b>155-2314</b>	<b>1.95</b>	<b>1.66</b>	<b>1.56</b>
021*	2.10	.0827	<b>155-2316</b>	<b>1.95</b>	<b>1.66</b>	<b>1.56</b>
023*	2.30	.0906	<b>155-2318</b>	<b>1.95</b>	<b>1.66</b>	<b>1.56</b>

Six-piece minimum; please order in multiples of six.

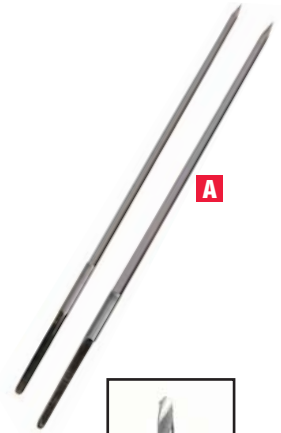

**A**



**B**



**C**



**D**



**E**



**F**



Drills sold by the dozen



**A**

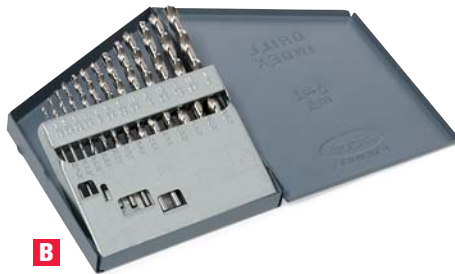

**B**



**C**



**D**



**E**



**F**

## **A, B** Blue Ribbon™ HS Twist Drills – Jobbers Length

Made in USA of the finest high-speed steel. Heat-treated to a hardness of 63–65 HRC. Precision-ground to a tolerance of +.0000–.0003". Inspected under a 20X stereomicroscope before shipping. Can be used in adapter chucks (see below).

### Wire Gauge Sizes

Diameter Size (inches)	Item#	DOZEN	
		1-11	12+
50 .070	<b>155-0500</b>	<b>\$14.75</b>	<b>\$13.28</b>
51 .067	<b>155-0510</b>	<b>14.75</b>	<b>13.28</b>
52 .0635	<b>155-0520</b>	<b>14.75</b>	<b>13.28</b>
53 .0595	<b>155-0530</b>	<b>14.75</b>	<b>13.28</b>
54 .055	<b>155-0540</b>	<b>14.75</b>	<b>13.28</b>
55 .052	<b>155-0550</b>	<b>14.75</b>	<b>13.28</b>
56 .0465	<b>155-0560</b>	<b>14.75</b>	<b>13.28</b>
57 .043	<b>155-0570</b>	<b>14.75</b>	<b>13.28</b>
58 .042	<b>155-0580</b>	<b>14.75</b>	<b>13.28</b>
59 .041	<b>155-0590</b>	<b>14.75</b>	<b>13.28</b>
60 .040	<b>155-0600</b>	<b>14.75</b>	<b>13.28</b>
61 .039	<b>155-0610</b>	<b>14.75</b>	<b>13.28</b>
62 .038	<b>155-0620</b>	<b>14.75</b>	<b>13.28</b>
63 .037	<b>155-0630</b>	<b>14.75</b>	<b>13.28</b>
64 .036	<b>155-0640</b>	<b>14.75</b>	<b>13.28</b>
65 .035	<b>155-0650</b>	<b>14.75</b>	<b>13.28</b>
66 .033	<b>155-0660</b>	<b>14.75</b>	<b>13.28</b>
67 .032	<b>155-0670</b>	<b>14.75</b>	<b>13.28</b>
68 .031	<b>155-0680</b>	<b>14.75</b>	<b>13.28</b>
69 .0292	<b>155-0690</b>	<b>16.60</b>	<b>14.94</b>
70 .028	<b>155-0700</b>	<b>16.60</b>	<b>14.94</b>
71 .026	<b>155-0710</b>	<b>20.20</b>	<b>18.18</b>
72 .025	<b>155-0720</b>	<b>20.20</b>	<b>18.18</b>
73 .024	<b>155-0730</b>	<b>20.20</b>	<b>18.18</b>
74 .0225	<b>155-0740</b>	<b>20.20</b>	<b>18.18</b>

Description	Item#	Each
<b>A.</b> Wire Gauge Drill Set, sizes 61 to 80, with Metal Index Case	<b>155-2030</b>	<b>\$39.30</b>
12 Wire Gauge Drills in tube: sizes 55, 57, 60, 62, 64, 65, 66, 68, 70, 72, 73, 75	<b>155-2010</b>	<b>16.25</b>
20 Wire Gauge Drills in tube: sizes 61 to 80	<b>155-2020</b>	<b>34.50</b>
Metal Drill Index Case for drills 61 to 80	<b>155-2000</b>	<b>6.50</b>
<b>B.</b> Fractional Inch Drill Set, 1/16" to 1/4", with Metal Index Case	<b>155-2038</b>	<b>26.98</b>
13 Fractional Inch Drills in tube: 1/16" to 1/4"	<b>155-2035</b>	<b>23.30</b>
Metal Drill Index Case for drills 1/16" to 1/4"	<b>155-2036</b>	<b>5.10</b>

## **C** Automatic Center Punch

An extremely accurate tool for centering drill hole points. Obtain variable depth impressions by adjusting the knurled head. Simply depress head for a sharp blow to the work surface. Hammering not required. Measures 4<sup>3/4</sup>" long.

Description	Item#	Each
<b>C.</b> Automatic Center Punch	<b>814-1100</b>	<b>\$24.50</b>
Replacement Tip	814-1102	3.95

## **D, E, F** Adapter Chucks – 3/32" Shank

For holding small diameter drills. Right-hand threads. Max. operating speed: 10,000rpm.

Collet Capacity	Item#	Each
<b>D.</b> 2.77mm (.109")	<b>840-3230</b>	<b>\$10.35</b>
<b>E.</b> 2.62mm (.103")	<b>840-3220</b>	<b>10.35</b>
<b>F.</b> 1.00mm (.039")	<b>840-3210</b>	<b>10.35</b>



**A Gesswein® Solid Carbide Drills**

**Jobbers Length, Fractional Inch Sizes**

Standard spiral, two-flute long-life drills with 118° drill points. Use on tool steels, cast steel, aluminum, bronze and nonmetallic materials. All drills are machine-ground (many by CNC). Gesswein Carbide Drills have consistent, uniform flute depths, so they produce dependable results order-to-order.

**Tolerances:**

Drill diameter +.0000/-.0005"  
Shank diameter +.000/-0.001"

Size	Diameter (inches)	Head Length	Overall Length	Item#	Each
1/32"	.0312	1/2"	1 1/4"	<b>155-2135</b>	<b>\$6.50</b>
3/64"	.0468	3/4"	1 1/2"	<b>155-2140</b>	<b>7.60</b>
1/16"	.0625	3/4"	1 1/2"	<b>155-2145</b>	<b>7.70</b>
5/64"	.0781	7/8"	1 3/4"	<b>155-2150</b>	<b>8.15</b>
3/32"	.0937	1"	2"	<b>155-2155</b>	<b>9.20</b>
7/64"	.1094	1 1/4"	2 1/4"	<b>155-2160</b>	<b>9.95</b>
1/8"	.1250	1 1/4"	2 1/4"	<b>155-2165</b>	<b>9.95</b>
9/64"	.1406	1 3/8"	2 1/2"	<b>155-2170</b>	<b>12.35</b>
5/32"	.1562	1 3/8"	2 1/2"	<b>155-2175</b>	<b>12.95</b>
11/64"	.1719	1 5/8"	2 3/4"	<b>155-2180</b>	<b>15.25</b>
3/16"	.1875	1 5/8"	2 3/4"	<b>155-2185</b>	<b>15.50</b>
13/64"	.2031	1 3/4"	3"	<b>155-2190</b>	<b>18.95</b>
7/32"	.2187	1 3/4"	3"	<b>155-2195</b>	<b>19.20</b>
15/64"	.2344	2"	3 1/4"	<b>155-2200</b>	<b>22.75</b>
1/4"	.2500	2"	3 1/4"	<b>155-2205</b>	<b>22.75</b>

**A. 6-Piece Set (one each of following popular sizes: 1/16", 1/8", 3/16", 1/4", 5/16", 3/8")** **155-2207 141.15**



**A**

**B Gesswein® Solid Carbide Combined Drills and Countersinks**

**Double-Ended with 60° Included Angle**

**Tolerances:**

Drill Diameter +.003/-0.000"  
Body Diameter -.0001/-0.0005"

Size	Diameter Body	Diameter Drill	Approx. Overall Length	Item#	Each
00	1/8"	.025"	1 1/2"	<b>155-2275</b>	<b>\$13.85</b>
0	1/8"	1/32"	1 1/2"	<b>155-2276</b>	<b>12.90</b>
1	1/8"	3/64"	1 1/2"	<b>155-2278</b>	<b>12.20</b>
2	3/16"	5/64"	1 7/8"	<b>155-2279</b>	<b>18.50</b>
3	1/4"	7/64"	2"	<b>155-2280</b>	<b>21.10</b>
4	5/16"	1/8"	2 1/8"	<b>155-2281</b>	<b>28.80</b>
5	7/16"	3/16"	2 3/4"	<b>155-2282</b>	<b>40.95</b>
6	1/2"	7/32"	3"	<b>155-2283</b>	<b>52.80</b>

**B. 8-Piece Set (one of each)** **155-2290 214.50**



**B**



## **A, B** Solid Carbide Square-Nose End Mills

Made of premium micro-grain carbide for superior performance and greater wear resistance. Stay sharp longer than regular carbide end mills, with less chipping and breaking. Available in two-flute and four-flute styles. Right-hand, center cutting, 30° spiral.

### Tolerances:

Cutting Diameter +.0000/-.0020"  
Shank Diameter -.0001/-.0004"

Cutting Diameter	Shank Diameter	Head Length	Overall Length	Two-Flute Item#	Four-Flute Item#	Each
1/16"	1/8"	3/16"	1 1/2"	<b>156-0070</b>	<b>156-0060</b>	<b>\$9.05</b>
5/64"	1/8"	1/4"	1 1/2"	<b>156-0110</b>	<b>156-0100</b>	<b>9.05</b>
3/32"	1/8"	3/8"	1 1/2"	<b>156-0150</b>	<b>156-0140</b>	<b>9.05</b>
1/8"	1/8"	1/2"	1 1/2"	<b>156-0220</b>	<b>156-0210</b>	<b>9.10</b>
5/32"	3/16"	9/16"	2"	<b>156-0300</b>	<b>156-0290</b>	<b>11.85</b>
3/16"	3/16"	5/8"	2"	<b>156-0380</b>	<b>156-0370</b>	<b>12.15</b>
7/32"	1/4"	5/8"	2 1/2"	<b>156-0460</b>	<b>156-0450</b>	<b>14.90</b>
1/4"	1/4"	3/4"	2 1/2"	<b>156-0540</b>	<b>156-0530</b>	<b>15.60</b>
9/32"	5/16"	3/4"	2 1/2"	<b>156-0620</b>	-	<b>16.90</b>
9/32"	5/16"	3/4"	2 1/2"	-	<b>156-0610</b>	<b>16.85</b>
5/16"	5/16"	13/16"	2 1/2"	<b>156-0700</b>	-	<b>17.60</b>
5/16"	5/16"	13/16"	2 1/2"	-	<b>156-0690</b>	<b>19.25</b>
11/32"	3/8"	1"	2 1/2"	<b>156-0780</b>	<b>156-0770</b>	<b>22.25</b>
3/8"	3/8"	1"	2 1/2"	<b>156-0860</b>	<b>156-0850</b>	<b>22.25</b>
7/16"	7/16"	1"	2 3/4"	<b>156-1020</b>	<b>156-1010</b>	<b>32.70</b>
1/2"	1/2"	1"	3"	<b>156-1180</b>	<b>156-1170</b>	<b>37.95</b>
5/8"	5/8"	1 1/4"	3 1/2"	<b>156-1260</b>	<b>156-1250</b>	<b>71.95</b>
3/4"	3/4"	1 1/2"	4"	<b>156-1340</b>	<b>156-1330</b>	<b>106.25</b>

### **B.** 6-Piece Set (one each

of following popular sizes:

1/8", 3/16", 1/4", 5/16", 3/8", 1/2" diameters) **156-1500** **156-1510** **125.50**



## **C, D** Solid Carbide Ball-Nose End Mills

Made of premium micro-grain carbide for superior performance and greater wear resistance. Stay sharp longer than regular carbide end mills, with less chipping and breaking. Available in two-flute and four-flute styles. Right-hand, center cutting, 30° spiral. May be up to 1/8" shorter than square-nose mills in head length and overall length.

### Tolerances:

Cutting Diameter +.0000/-.0020"  
Shank Diameter -.0001/-.0004"

Cutting Diameter	Shank Diameter	Head Length	Overall Length	Two-Flute Item#	Four-Flute Item#	Each
3/32"	1/8"	9/32"	1 1/2"	-	<b>156-0160</b>	<b>\$11.95</b>
1/8"	1/8"	1/2"	1 1/2"	<b>156-0240</b>	<b>156-0230</b>	<b>10.32</b>
3/16"	3/16"	5/8"	2"	<b>156-0400</b>	<b>156-0390</b>	<b>14.65</b>
1/4"	1/4"	3/4"	2 1/2"	<b>156-0560</b>	<b>156-0550</b>	<b>18.85</b>
3/8"	3/8"	1"	2 1/2"	<b>156-0880</b>	<b>156-0870</b>	<b>26.65</b>
1/2"	1/2"	1"	3"	-	<b>156-1190</b>	<b>45.50</b>

### **D.** 6-Piece Set (one each

of Two-Flute in following sizes:

5/16", 1/8", 3/16", 1/4", 3/8", 1/2" diameters) **156-1505** **145.25**

**A - I Solid Carbide Three-Flute End Mills for Aluminum**

Square-nose end mills for effective chip removal at high feed rates on aluminum alloys, copper alloys, brass/bronze and plastics. Produce lower cutting forces than comparable tools. Feature unique symmetrical end gashing that provides improved balance at high speeds for a better finish and more effective plunging than conventional designs. Cutting and shank diameter tolerances: +.0000/-.0020 and -.0001"/-.0004".

Cutting Diameter	Shank Diameter	Head Length	Overall Length	Three-Flute Item#	Each
<b>A.</b> 1/8"	1/8"	3/8"	1 1/2"	<b>156-4155</b>	<b>\$16.95</b>
<b>B.</b> 3/16"	3/16"	9/16"	2"	<b>156-4160</b>	<b>25.75</b>
<b>C.</b> 1/4"	1/4"	3/8"	2"	<b>156-4165</b>	<b>29.85</b>
		3/4"	2 1/2"	<b>156-4170</b>	<b>33.25</b>
<b>D.</b> 5/16"	5/16"	1 1/4"	3 1/2"	<b>156-4175</b>	<b>37.65</b>
		7/16"	2"	<b>156-4180</b>	<b>33.45</b>
		5/8"	2 1/2"	<b>156-4185</b>	<b>38.50</b>
<b>E.</b> 3/8"	3/8"	1 1/4"	4"	<b>156-4190</b>	<b>50.50</b>
		1/2"	2"	<b>156-4195</b>	<b>47.50</b>
		1"	2 1/2"	<b>156-4200</b>	<b>48.45</b>
<b>F.</b> 1/2"	1/2"	1 1/2"	3 1/2"	<b>156-4205</b>	<b>56.50</b>
		1 1/4"	3 1/4"	<b>156-4220</b>	<b>72.40</b>
		2"	4"	<b>156-4225</b>	<b>110.50</b>
		3 1/8"	6"	<b>156-4230</b>	<b>139.25</b>
<b>G.</b> 5/8"	5/8"	3/4"	3"	<b>156-4235</b>	<b>129.95</b>
		1 5/8"	3 3/4"	<b>156-4240</b>	<b>157.40</b>
		2 1/2"	5"	<b>156-4250</b>	<b>210.00</b>
		3 3/4"	6"	<b>156-4255</b>	<b>240.35</b>
<b>H.</b> 3/4"	3/4"	1"	3"	<b>156-4260</b>	<b>212.75</b>
		1 5/8"	4"	<b>156-4265</b>	<b>220.00</b>
		2 1/4"	5"	<b>156-4270</b>	<b>265.00</b>
		3 1/4"	6"	<b>156-4275</b>	<b>298.00</b>
<b>I.</b> 1"	1"	1 1/4"	4"	<b>156-4280</b>	<b>325.45</b>
		2"	4 1/2"	<b>156-4285</b>	<b>376.00</b>
		2 5/8"	6"	<b>156-4290</b>	<b>398.00</b>
		3 1/4"	6"	<b>156-4295</b>	<b>415.60</b>



**J ESP Anti-Rust Spray**

Protects all metal surfaces from rust and corrosion after cleaning. Neutralizes fingerprints and displaces water. Contains no CFCs.

Description	Item#	EACH Prices	
		1-11	12+
ESP Anti-Rust Spray, 16 fl. oz.	<b>825-1450</b>	<b>\$13.95</b>	<b>\$12.56</b>



**Speed/Feed Recommendations for End Mills for Aluminum (see above and p. 190)**

Cutting Diameter	Feed Rate Per Tooth			
	Aluminum Alloys 1,600–2,000 sfm 490–610 m/min	Copper Alloys 800–1,200 sfm 245–365 m/min	Brass/Bronze 800–1,500 sfm 245–455 m/min	Plastics 1,200–1,600 sfm 365–490 m/min
1/8"	0.0015	0.0015	0.0015	0.0030
3/16"	0.0025	0.0025	0.0025	0.0050
1/4"	0.0030	0.0030	0.0030	0.0060
5/16"	0.0040	0.0040	0.0040	0.0080
3/8"	0.0050	0.0050	0.0050	0.0100
1/2"	0.0060	0.0060	0.0060	0.0120
5/8"	0.0070	0.0070	0.0070	0.0140
3/4"	0.0080	0.0080	0.0080	0.0160
1"	0.0100	0.0100	0.0100	0.0180

## A, B Solid Carbide Two-Flute End Mills for Aluminum

Square- and ball-nose end mills for effective chip removal at high feed rates on aluminum alloys, copper alloys, brass/bronze and plastics. Produce lower cutting forces than comparable tools. Feature unique symmetrical end gashing that provides improved balance at high speeds for a better finish and more effective plunging than conventional designs. Cutting and shank diameter tolerances: +.0000/-.0020 and -.0001"/-.0004".



**A**

A. Square-Nose Diameter	Shank Diameter	Head Length	Overall Length	Two-Flute Item#	Each
1/8"	1/8"	3/8"	1 1/2"	<b>156-4310</b>	<b>\$11.95</b>
3/16"	3/16"	9/16"	2"	<b>156-4315</b>	<b>16.95</b>
1/4"	1/4"	3/4"	2 1/2"	<b>156-4320</b>	<b>21.95</b>
5/16"	5/16"	13/16"	2 1/2"	<b>156-4325</b>	<b>27.95</b>
3/8"	3/8"	1"	2 1/2"	<b>156-4330</b>	<b>32.35</b>
1/2"	1/2"	1 1/4"	3 1/4"	<b>156-4335</b>	<b>47.85</b>
5/8"	5/8"	1 5/8"	3 3/4"	<b>156-4340</b>	<b>103.85</b>
3/4"	3/4"	1 5/8"	4"	<b>156-4345</b>	<b>145.65</b>
1"	1"	2"	4 1/2"	<b>156-4350</b>	<b>248.35</b>



**B**

B. Ball-Nose Diameter	Shank Diameter	Head Length	Overall Length	Two-Flute Item#	Each
1/8"	1/8"	3/8"	1 1/2"	<b>156-4355</b>	<b>\$12.50</b>
3/16"	3/16"	9/16"	2"	<b>156-4360</b>	<b>18.70</b>
1/4"	1/4"	3/4"	2 1/2"	<b>156-4365</b>	<b>24.15</b>
5/16"	5/16"	13/16"	2 1/2"	<b>156-4370</b>	<b>30.70</b>
3/8"	3/8"	1"	2 1/2"	<b>156-4375</b>	<b>35.60</b>
1/2"	1/2"	1 1/4"	3 1/4"	<b>156-4380</b>	<b>52.60</b>
5/8"	5/8"	1 5/8"	3 3/4"	<b>156-4385</b>	<b>114.25</b>
3/4"	3/4"	1 5/8"	4"	<b>156-4390</b>	<b>159.95</b>
1"	1"	2"	4 1/2"	<b>156-4395</b>	<b>273.45</b>

## C Power-Carb® Solid Carbide Six-Flute End Mills

Square-nose end mills for wet or dry milling of mold and die steels up to 65 HRC. Ideal for slot and finish milling. Coated with AlTiN for maximum heat and wear resistance. Feature eccentric relief and extreme negative radial intake for increased edge strength, high helix and multiple edges for better rigidity and feed rate capabilities and long shanks for extended reach. Cutting and shank diameter tolerances: +.0000/-.0020 and -.0001"/-.0004".



**C**

Cutting Diameter	Shank Diameter	Head Length	Overall Length	Six-Flute Item#	Each
1/4"	1/4"	17/32"	3 1/2"	<b>156-4321</b>	<b>\$81.85</b>
5/16"	5/16"	11/16"	4"	<b>156-4322</b>	<b>107.95</b>
3/8"	3/8"	13/16"	4"	<b>156-4323</b>	<b>117.95</b>
1/2"	1/2"	1 3/32"	4 1/2"	<b>156-4324</b>	<b>165.00</b>

## D Turbo-Carb® Solid Carbide Two-Flute End Mills

Ball-nose end mills for dry milling of mold and die steels up to 60 HRC. Ideal for use on complex, contoured shapes. Coated with AlTiN for maximum heat and wear resistance. Feature durable construction, helical ball gashing for improved shearing action and long shanks for extended reach. Cutting and shank diameter tolerances: +.0000/-.0020 and -.0001"/-.0004".



**D**

Cutting Diameter	Shank Diameter	Head Length	Overall Length	Two-Flute Item#	Each
1/32"	1/4"	1/32"	3"	<b>156-4300</b>	<b>\$75.95</b>
1/16"	1/4"	1/16"	3"	<b>156-4301</b>	<b>75.95</b>
3/32"	1/4"	3/32"	3"	<b>156-4302</b>	<b>75.95</b>
1/8"	1/4"	1/8"	3"	<b>156-4303</b>	<b>85.95</b>
3/16"	1/4"	3/16"	3"	<b>156-4304</b>	<b>87.50</b>
1/4"	1/4"	1/4"	3 1/2"	<b>156-4305</b>	<b>90.95</b>
5/16"	5/16"	5/16"	4"	<b>156-4306</b>	<b>103.95</b>
3/8"	3/8"	3/8"	4"	<b>156-4307</b>	<b>114.75</b>
1/2"	1/2"	1/2"	4 1/2"	<b>156-4308</b>	<b>169.00</b>



**A - D Gesswein® Super Carbide Blanks and Cutters**

Stay sharper and last up to five times longer than standard carbide due to high cobalt content. Ideal for use on tool steel, stainless steel, Inconel and other high-temperature metals. Centerless ground. Overall tolerance: +.0000/-0.0005". Split tolerance: +.000/-0.001". Hardness: 91.8 HRC. Density: 14.74g/cc. Transverse rupture strength: 400,000 PSI. Use with pantograph or duplicating machines. Sharpen with Accu-Finish II (see p. 192).

Description	Dia. x L	Item#	EACH Prices	
			1-5	6+
<b>A. Round Blank</b>	1/8" x 1 1/2"	<b>150-4000</b>	<b>\$3.45</b>	<b>\$2.93</b>
	1/8" x 3"	<b>150-4010</b>	<b>5.45</b>	<b>4.63</b>
	1/8" x 6"	<b>150-4016</b>	<b>11.25</b>	<b>9.56</b>
	3/16" x 2"	<b>150-4020</b>	<b>5.70</b>	<b>4.85</b>
	3/16" x 6"	<b>150-4026</b>	<b>19.25</b>	<b>16.36</b>
	1/4" x 2"	<b>150-4030</b>	<b>9.05</b>	<b>7.69</b>
	1/4" x 6"	<b>150-4036</b>	<b>33.10</b>	<b>28.14</b>
<b>B. Half-Round Blank</b>	1/8" x 1 1/2"	<b>150-5000</b>	<b>10.65</b>	<b>9.05</b>
	3/16" x 2"	<b>150-5005</b>	<b>23.40</b>	<b>19.89</b>
	1/4" x 2"	<b>150-5010</b>	<b>33.45</b>	<b>28.43</b>
	3/8" x 2"	<b>150-5015</b>	<b>59.15</b>	<b>50.28</b>
<b>C. Single-Split Cutter</b>	1/8" x 1 1/2"	<b>150-3000</b>	<b>5.25</b>	<b>4.46</b>
	3/16" x 1 1/2"	<b>150-3010</b>	<b>7.35</b>	<b>6.25</b>
	1/4" x 2"	<b>150-3020</b>	<b>12.90</b>	<b>10.97</b>
	3/8" x 2"	<b>150-3030</b>	<b>24.80</b>	<b>21.08</b>
<b>D. Double-Split Cutter</b>	1/8" x 1 1/2"	<b>150-5100</b>	<b>7.35</b>	<b>6.25</b>
	3/16" x 2"	<b>150-5105</b>	<b>12.75</b>	<b>10.84</b>
	1/4" x 2"	<b>150-5110</b>	<b>17.40</b>	<b>14.79</b>
	3/8" x 2"	<b>150-5115</b>	<b>24.15</b>	<b>20.53</b>



**E - G Gesswein® High-Speed Steel Blanks and Cutters**

Use with CNC, pantograph or duplicating machines. Made of premium high-speed steel and heat-treated to a hardness of 62-65 HRC in a process that retains toughness. Not as durable as carbide cutters but effective for tasks that require greater tip resiliency, such as making deep, fine cuts. We suggest they be ground by plunge-cut or cross-feed method with a soft grinding wheel. Centerless ground to a tolerance of +.0000"/-0.0002", with flats that are within .001" above center. All single-split and double-split sizes have flat length of 0.565" except #151-9630 and #151-9660, which have flat length of 0.400".

Description	Dia. x L	Item#	EACH Prices	
			1-5	6+
<b>E. Round Blank</b>	1/8" x 1 1/2"	<b>151-9600</b>	<b>\$4.95</b>	<b>\$4.21</b>
	3/16" x 2"	<b>151-9605</b>	<b>6.50</b>	<b>5.53</b>
	1/4" x 2 1/4"	<b>151-9610</b>	<b>7.50</b>	<b>6.38</b>
	5/16" x 2 3/8"	<b>151-9615</b>	<b>10.65</b>	<b>9.05</b>
	3/8" x 2 1/2"	<b>151-9620</b>	<b>14.25</b>	<b>12.11</b>
<b>F. Single-Split Cutter</b>	1/2" x 2 1/2"	<b>151-9625</b>	<b>22.35</b>	<b>19.00</b>
	1/8" x 1 1/2"	<b>151-9630</b>	<b>7.50</b>	<b>6.38</b>
	3/16" x 2"	<b>151-9635</b>	<b>10.65</b>	<b>9.05</b>
	1/4" x 2 1/4"	<b>151-9640</b>	<b>13.95</b>	<b>11.86</b>
	5/16" x 2 3/8"	<b>151-9645</b>	<b>21.50</b>	<b>18.28</b>
<b>G. Double-Split Cutter</b>	3/8" x 2 1/2"	<b>151-9650</b>	<b>26.85</b>	<b>22.82</b>
	1/2" x 2 1/2"	<b>151-9655</b>	<b>42.95</b>	<b>36.51</b>
	1/8" x 1 1/2"	<b>151-9660</b>	<b>10.25</b>	<b>8.71</b>
	3/16" x 2"	<b>151-9665</b>	<b>15.25</b>	<b>12.96</b>
	1/4" x 2 1/4"	<b>151-9670</b>	<b>20.75</b>	<b>17.64</b>
	5/16" x 2 3/8"	<b>151-9675</b>	<b>32.50</b>	<b>27.63</b>
	3/8" x 2 1/2"	<b>151-9680</b>	<b>39.50</b>	<b>33.58</b>
	1/2" x 2 1/2"	<b>151-9685</b>	<b>63.80</b>	<b>54.23</b>





**A**

## **A** Accu-Finish II Precision Tool Sharpener

Accu-Finish II works with diamond and ceramic wheels for sharpening carbides, ceramics, high-speed steels and most other tool materials. Runs at 300rpm to keep heat and vibration from ruining your tools. Maintains optimal tool condition for longer life and better finishes on workpieces. Switches between horizontal and vertical modes of operation without tools. Features precision table assembly with sealed ball bearings preloaded on hardened ways and carriage that can be locked securely in position, adjustable table elevation scale for repeated accuracy and tool guide with built-in protractor marks for setting exact angles.

Includes machine with continuous-duty reversible motor, wheel wetting agent, spray bottle, wheel cleaning stick, wheel wrench and instructions. Accommodates 6" wheels (see below). Can be mounted on a bench-height cabinet (see below). UL listed.

### Specifications:

Operating Speed	300rpm (reversible)
Electrical	115V, 60Hz (230V, 50Hz available)
Dimensions	13"W x 14"D x 10"H
Ship. Wt.	50 lbs. (approx.)



**B**



**C**

**D**

## **B - D** Diamond Wheels, Ceramic Wheel and Diamond Spray Compound

Use diamond wheels for roughing and sharpening carbides, high-speed steels and other tough tool materials, ceramic lap for applying final mirror finish and diamond spray for periodically charging ceramic lap (sold in a 2 fl. oz. bottle that contains 1 ct. diamond).

Description	Grit	Application	Item#	Each
<b>B.</b> 6" Diamond Wheel	260	Roughing	<b>856-0024</b>	<b>\$148.00</b>
	360	Faster roughing (grooved)	<b>856-0026</b>	<b>144.00</b>
	600	Roughing and sharpening	<b>856-0030</b>	<b>129.00</b>
	1200	Fine sharpening	<b>856-0034</b>	<b>135.00</b>
<b>C.</b> 6" Ceramic Lap	–	Mirror finishing	<b>856-0258</b>	<b>188.60</b>
<b>D.</b> Diamond Spray	–	Charging ceramic lap	<b>856-0260</b>	<b>23.90</b>



**E**

## **E** Foot Switch

An on/off foot switch highly recommended for hands-free operation.

Description	Item#	Each
Foot Switch for Accu-Finish II and Power Hone	<b>856-0036</b>	<b>\$34.00</b>



**F**

## **F** Insert Holders

Each holder grips insert by top and bottom edge. Ideal for working on sides, noses and edges of carbide inserts. Measures 4"L x 3/8"W x 1/2"H.

Description	Item#	Each
Holder for 1/8"–3/16" thick inserts	<b>856-0038</b>	<b>\$38.00</b>
<b>F.</b> Holder for 3/16"–1/4" thick inserts	<b>856-0040</b>	<b>38.00</b>



**G**

*Cabinet shown with Accu-Finish II and accessories not included.*

## **G** Accu-Finish II Cabinet

This heavy-duty steel cabinet turns your Accu-Finish II into an organized sharpening center. Features slots for wheels and accessories in the tabletop and base with door that conceals two built-in shelves for additional storage space. Includes bolts for mounting on floor and kit for mounting Accu-Finish II to the tabletop.

### Specifications:

Dimensions	28 1/2"W x 14 1/2"D x 35"H
Footprint	13 1/2"W x 12"D
Ship. Wt.	69 lbs. (approx.)

Description	Item#	Each
Accu-Finish II Cabinet	<b>856-0005</b>	<b>\$448.00</b>

**A EDtapper**

**The revolutionary EDM tapping accessory!**

The EDtapper adds CNC capabilities to your sinker EDM machine, allowing you to tap a wide variety of holes. Just attach to machine as you would an electrode with magnet or shank, affix electrode to electrode holder, position appropriately, extend and fix base foot, adjust horizontal movement scale, set the depth of sinking to 42mm and operate. Complete setup takes just 5 minutes!

**Features:**

- Adds CNC capabilities to your sinker EDM machine.
- Takes just 5 minutes to set up and operate.
- Converts vertical movement to orbital movement.
- Forms the whole depth of the thread in a single orbital cycle.
- Eliminates need for interfering with machine's circuits—attach as an electrode holder, and it's ready to operate.
- Maintains machine features of sinking and withdrawal.
- Controlled via the control panel of the machine.
- Designed so electrode withdrawal is made towards hole center, not in direction from which it came (improves flushing).
- Flexible hose for spraying fluid right through the electrode when making blind threads.
- Two positions for electrode attachment: orbital fixed angular for threads, circlip slots, inverted cones and more, or orbital and rotational about its axis for circular symmetrical shapes.
- Special attachment for easy electrode removal and replacement without losing presets for threads (prevents cross-threading).

**Specifications:**

	English	Metric
Unit Weight	4.4 lbs.	2kg
Head Resistance	17.6 lbs.	8kg
Max. Electrode Wt.	10.6 oz.	300g
Work Stroke	1.65"	42mm
Radial Feed Movement	0.125"	3.2mm
Max. Formable Pitch	0.2"	5mm
Feed Scale Division	0.001"	0.02mm
Foot Stroke	2.15"	55mm
Electrode Rod Dia.	0.125"–0.785"	3mm–20mm
Max. Unit Width	6"	150mm
Tapping Accuracy with Respect to Hole	±0.005" (true position 0.01")	±0.125mm (true position 0.25mm)

**EDtapper Performances\*:**

M5 thread to depth of 8mm takes 12 minutes (roughness 5.2 Ra)

M10 thread to depth of 16mm takes 18 minutes (roughness 6 Ra)

M12 thread to depth of 20mm made in 2 steps:

Step 1 Coarse: 25 minutes (roughness 6.8 Ra)

Step 2 Fine: 6 minutes (roughness 4.8 Ra)

Similar results in accordance for:

NF10-32 to depth of 0.3"

NC<sup>3</sup>/<sub>8</sub> to depth of 0.625"

NC<sup>1</sup>/<sub>2</sub> to depth of 0.75"

*\*Values may vary from one machine type to another.*

Description	Item#	Each
EDtapper, English	<b>511-2000</b>	<b>\$1,799.00</b>
<b>A.</b> EDtapper, Metric	<b>511-2005</b>	<b>1,799.00</b>





## Gesswein® Diamond Files

Premium diamond files for use on steels, carbides, ceramics, plastics and more. Features 100% synthetic diamonds—more consistent in shape than natural diamonds—plated onto high-strength steel blanks for consistent cutting and long life.

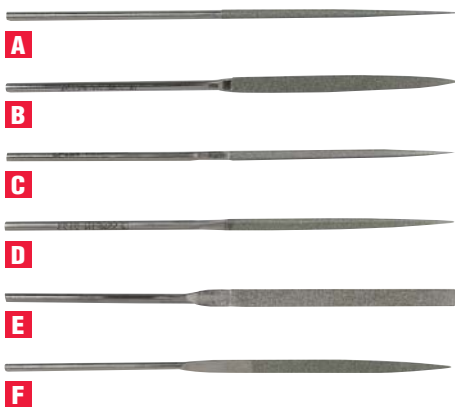

### A - F Gesswein® Diamond Needle Files

Diamond needle files with 3mm round handles. Measure 5½" long. Plated ends measure 2¾" long. Can be used alone or with needle file handles (see p. 211).

Style	Shape	Grit	Item#	EACH Prices		
				1-4	5-9	10+
A. Round		150	<b>240-2162</b>	<b>\$22.00</b>	<b>\$20.90</b>	<b>\$19.80</b>
B. Half-Round		150	<b>240-2152</b>	<b>22.00</b>	<b>20.90</b>	<b>19.80</b>
C. Square		150	<b>240-2142</b>	<b>22.00</b>	<b>20.90</b>	<b>19.80</b>
D. Three-Square		150	<b>240-2132</b>	<b>22.00</b>	<b>20.90</b>	<b>19.80</b>
E. Equalling		150	<b>240-2112</b>	<b>22.00</b>	<b>20.90</b>	<b>19.80</b>
F. Barrette		150	<b>240-2102</b>	<b>22.00</b>	<b>20.90</b>	<b>19.80</b>
6-Piece Set (one of each)			<b>240-2200</b>	<b>125.00</b>	<b>-</b>	<b>-</b>



### G - K Gesswein® Diamond Hand Files

Heavy-duty diamond hand files with square shanks for use by hand or with handles. Measure 215mm (8½") long. Plated ends measure a generous 80mm (3⅝") long.

Style	Shape	W x Thick	Grit	Item#	Each
G. Equalling		11.0 x 3.5mm	100	<b>241-0746</b>	<b>\$39.95</b>
			200	<b>241-0747</b>	<b>39.95</b>
			400	<b>241-0748</b>	<b>39.95</b>
H. Square		6.3 x 6.3mm	100	<b>241-0735</b>	<b>39.95</b>
			200	<b>241-0736</b>	<b>39.95</b>
			400	<b>241-0737</b>	<b>39.95</b>
I. Half-Round		10.5 x 4.4mm	100	<b>241-0749</b>	<b>39.95</b>
			200	<b>241-0730</b>	<b>39.95</b>
			400	<b>241-0731</b>	<b>39.95</b>
J. Round		5.0mm	100	<b>241-0732</b>	<b>39.95</b>
			200	<b>241-0733</b>	<b>39.95</b>
			400	<b>241-0734</b>	<b>39.95</b>
K. Three-Square		7.7mm	100	<b>241-0738</b>	<b>39.95</b>
			200	<b>241-0739</b>	<b>39.95</b>
			400	<b>241-0740</b>	<b>39.95</b>
5-Piece Set (one of each style)			100	<b>241-0741</b>	<b>169.95</b>
			200	<b>241-0742</b>	<b>169.95</b>
			400	<b>241-0743</b>	<b>169.95</b>



### L - O Gesswein® Tapered Diamond Hand Files

Tapered diamond hand files with slim handles for sure grip. Measure 180mm (7") long. Plated ends measure 40mm long on 2mm wide files, 50mm long on all others.

Style	Shape	W x Thick	Grit	Item#	Each
L. Flat		2 x 1.5-0.4mm	150	<b>241-0801</b>	<b>\$22.00</b>
			200	<b>241-0802</b>	<b>22.00</b>
			400	<b>241-0803</b>	<b>22.00</b>
M.		4 x 2.0-0.5mm	150	<b>241-0804</b>	<b>22.00</b>
			200	<b>241-0805</b>	<b>22.00</b>
			400	<b>241-0806</b>	<b>22.00</b>
N.		6 x 2.0-0.5mm	150	<b>241-0807</b>	<b>22.00</b>
			200	<b>241-0808</b>	<b>22.00</b>
			400	<b>241-0809</b>	<b>22.00</b>
O.		8 x 2.5-0.5mm	150	<b>241-0810</b>	<b>22.00</b>
			200	<b>241-0811</b>	<b>22.00</b>
			400	<b>241-0812</b>	<b>22.00</b>
12-Piece Set (one of each)				<b>241-0800</b>	<b>250.00</b>



**A - E Gesswein® Diamond Rifflers**

Curved, double-ended diamond files with square handles. Measure 6" long. Plated ends measure 1" long.

Style	Shape	Grit	Item#	EACH Prices		
				1-4	5-9	10+
A. 16R		150	<b>240-3165</b>	<b>\$25.00</b>	<b>\$23.75</b>	<b>\$22.50</b>
B. 18R		150	<b>240-3180</b>	<b>25.00</b>	<b>23.75</b>	<b>22.50</b>
C. 22R		150	<b>240-3222</b>	<b>25.00</b>	<b>23.75</b>	<b>22.50</b>
D. 24R		150	<b>240-3225</b>	<b>25.00</b>	<b>23.75</b>	<b>22.50</b>
E. 26R		150	<b>240-3230</b>	<b>25.00</b>	<b>23.75</b>	<b>22.50</b>
5-Piece Set (one of each)			<b>240-3250</b>	<b>115.00</b>	-	-

**F - R Gesswein® Diamond Poli Files**

Parallel diamond machine files for use in reciprocating handpieces (see pp. 90, 109 and 113). All have 3mm shanks. Measure approx. 2" long. Plated ends measure 5/8" long.

Style	Shape	W x Thick	Grit	Item#	Each
F. Flat		2 x 1mm	150	<b>240-1120*</b>	<b>\$12.50</b>
G.		3 x 1mm	150	<b>240-1130</b>	<b>12.50</b>
H.		4 x 1mm	150	<b>240-1140</b>	<b>12.50</b>
I.		5 x 2mm	150	<b>240-1150</b>	<b>12.50</b>
J. Three-Square		2mm	150	<b>240-1520*</b>	<b>12.50</b>
K.		3.5mm	150	<b>240-1535</b>	<b>12.50</b>
L.		4.5mm	150	<b>240-1545</b>	<b>12.50</b>
M. Crossing		2 x 1mm	150	<b>240-1410*</b>	<b>12.50</b>
N. Round		1mm	150	<b>240-1310</b>	<b>12.50</b>
O.		2mm	150	<b>240-1320*</b>	<b>12.50</b>
P.		3mm	150	<b>240-1330</b>	<b>12.50</b>
Q. Flat		4 x 1mm	150	<b>240-1230*</b>	<b>12.50</b>
R. Knife		4 x 1mm	150	<b>240-1610*</b>	<b>12.50</b>
6-Piece Set (one of each asterisked item)				<b>240-1706</b>	<b>71.00</b>
12-Piece Set (one of each except #240-1150)				<b>240-1712</b>	<b>142.00</b>

**S - V Gesswein® Tapered Diamond Poli Files**

Tapered diamond machine files for use in reciprocating handpieces (see pp. 90, 109 and 113). All have 3mm shanks. Plated ends measure 15mm (19/32") long with 1.4–0.3mm taper.

Style	Shape	W x L	Grit	Item#	Each
S. Flat		3 x 56mm	200	<b>241-0814</b>	<b>\$12.50</b>
			400	<b>241-0815</b>	<b>12.50</b>
			600	<b>241-0816</b>	<b>12.50</b>
T.		6 x 56mm	200	<b>241-0817</b>	<b>13.75</b>
			400	<b>241-0818</b>	<b>13.75</b>
			600	<b>241-0819</b>	<b>13.75</b>
U.		3 x 72mm	200	<b>241-0820</b>	<b>12.50</b>
			400	<b>241-0821</b>	<b>12.50</b>
			600	<b>241-0822</b>	<b>12.50</b>
V.		6 x 72mm	200	<b>241-0823</b>	<b>13.75</b>
			400	<b>241-0824</b>	<b>13.75</b>
			600	<b>241-0825</b>	<b>13.75</b>
12-Piece Set (one of each)				<b>241-0813</b>	<b>149.75</b>



## Spectra Diamond Files

High-quality diamond files at economical prices. Feature a combination of natural and synthetic diamonds firmly plated onto durable steel blanks. Made in Germany.



### A - E Spectra Medium Diamond Needle Files

Diamond needle files with 3mm round handles. Measure 5½" (14cm) long. Plated ends measure 2¾" long. Medium grit (D126, or U.S. standard 120/140).

Style	Shape	Item#	EACH Prices		
			1-4	5-9	10+
A. Equalling		241-0010	\$29.00	\$27.55	\$26.10
B. Flat-Pointed		241-0020	29.00	27.55	26.10
C. Half-Round		241-0030	29.00	27.55	26.10
D. Round		241-0040	29.00	27.55	26.10
E. Knife		241-0050	29.00	27.55	26.10
5-Piece Set (one of each)		241-0250	137.00	-	-

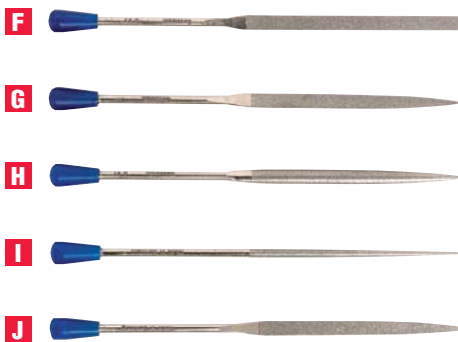

### F - J Spectra Fine Diamond Needle Files

Diamond needle files with 3mm round handles. Measure 5½" (14cm) long. Plated ends measure 2¾" long. Fine grit (D91, or U.S. standard 170/200).

Style	Shape	Item#	EACH Prices		
			1-4	5-9	10+
F. Equalling		241-0012	\$29.00	\$27.55	\$26.10
G. Flat-Pointed		241-0022	29.00	27.55	26.10
H. Half-Round		241-0032	29.00	27.55	26.10
I. Round		241-0042	29.00	27.55	26.10
J. Knife		241-0052	29.00	27.55	26.10
5-Piece Set (one of each)		241-0245	137.00	-	-



### K Spectra Diamond Escapement File

Diamond escapement file with 3/32" square handle. Measures 5½" (14cm) long. Plated end measures 1¾" long with 1/16"-1/32" taper. Very fine grit (D64, or U.S. standard 230/270).

Style	Shape	Item#	EACH Prices		
			1-4	5-9	10+
Round (tapered)		241-0150	\$29.95	\$28.45	\$26.96



### L - P Spectra Diamond Micro Files





Mini diamond files with 3/32" wide handles. Measure approx. 4" long except round, which measures approx. 3¾" long. Plated ends measure approx. 2" long with 1/16"-1/32" taper for round only. Very fine grit (D64, or U.S. standard 230/270).



Style	Shape	Item#	EACH Prices		
			1-4	5-9	10+
L. Round (tapered)		241-0500	\$15.00	\$14.25	\$13.50
M. Half-Round		241-0505	15.00	14.25	13.50
N. Square		241-0510	15.00	14.25	13.50
O. Three-Square		241-0515	15.00	14.25	13.50
P. Flat Hand		241-0520	15.00	14.25	13.50
5-Piece Set (one of each)		241-0525	71.00	-	-

**A - E Spectra Diamond Rifflers – Medium and Fine**



Curved, double-ended diamond files with square handles. Measure 6" long. Plated ends measure 1" long. Medium grit (D126, or U.S. standard 120/140) and fine grit (D91, or U.S. standard 170/200).

Style	Shape	Medium Item#	Fine Item#	EACH Prices		
				1-4	5-9*	10+*
<b>A. Flat</b>		<b>241-0195</b>	<b>241-0170</b>	<b>\$35.00</b>	<b>\$33.25</b>	<b>\$31.50</b>
<b>B. Three-Square</b>		<b>241-0200</b>	<b>241-0175</b>	<b>35.00</b>	<b>33.25</b>	<b>31.50</b>
<b>C. Square</b>		<b>241-0205</b>	<b>241-0180</b>	<b>35.00</b>	<b>33.25</b>	<b>31.50</b>
<b>D. Round</b>		<b>241-0210</b>	<b>241-0185</b>	<b>35.00</b>	<b>33.25</b>	<b>31.50</b>
<b>E. Oval</b>		<b>241-0215</b>	<b>241-0190</b>	<b>35.00</b>	<b>33.25</b>	<b>31.50</b>
Set of all five		<b>241-0310</b>	<b>241-0305</b>	<b>165.00</b>	<b>-</b>	<b>-</b>

\*Quantity discount for orders of one item# only, not assorted.

**F - N Spectra Diamond Poli Files – Medium**

Parallel diamond machine files for use in reciprocating handpieces (see pp. 90, 109 and 113). All have 3mm shanks. Measure approx. 2" long. Plated ends measure 25mm long on #241-0420, #241-0435 and #241-0440, 15mm long on all others. Medium grit (D126, or U.S. standard 120/140).

Style	Shape	Plated Size (mm)	Item#	EACH Prices		
				1-4	5-9	10+
<b>F. Flat</b>		2 x 1mm	<b>241-0400</b>	<b>\$18.90</b>	<b>\$17.96</b>	<b>\$17.01</b>
<b>G.</b>		3 x 1mm	<b>241-0405</b>	<b>18.90</b>	<b>17.96</b>	<b>17.01</b>
<b>H.</b>		4 x 1mm	<b>241-0410</b>	<b>18.90</b>	<b>17.96</b>	<b>17.01</b>
<b>I.</b>		5 x 2mm	<b>241-0415</b>	<b>18.90</b>	<b>17.96</b>	<b>17.01</b>
<b>J.</b>		5 x 2mm	<b>241-0420</b>	<b>18.90</b>	<b>17.96</b>	<b>17.01</b>
<b>K. Flat</b>		2 x 1mm	<b>241-0425</b>	<b>18.90</b>	<b>17.96</b>	<b>17.01</b>
<b>L.</b>		3 x 1mm	<b>241-0430</b>	<b>18.90</b>	<b>17.96</b>	<b>17.01</b>
<b>M.</b>		5 x 2mm	<b>241-0435</b>	<b>18.90</b>	<b>17.96</b>	<b>17.01</b>
<b>N. Round</b>		3mm	<b>241-0440</b>	<b>18.90</b>	<b>17.96</b>	<b>17.01</b>
Set of all nine			<b>241-0445</b>	<b>160.00</b>	<b>152.00</b>	<b>144.00</b>

**O 3M® Diamond Hand Files**

For filing hard-to-cut materials, finishing delicate surfaces, beveling edges, removing burrs and sharpening tools. Can be used wet or dry. Color-coded for easy grit identification.

Cutting Face

(L x W)	Color	Grit	Item#	Each
1½" x ¾"	Black	120	<b>240-3010</b>	<b>\$6.75</b>
	Red	200	<b>240-3011</b>	<b>6.30</b>
	Yellow	400	<b>240-3012</b>	<b>5.70</b>
	White	800	<b>240-3013</b>	<b>5.70</b>
1¾" x ½"	Black	120	<b>240-3014</b>	<b>6.40</b>
	Red	200	<b>240-3015</b>	<b>6.05</b>
	Yellow	400	<b>240-3016</b>	<b>5.55</b>
	White	800	<b>240-3017</b>	<b>5.55</b>
1¾" x ½" half-round	Black	120	<b>240-3018</b>	<b>6.45</b>
	Red	200	<b>240-3019</b>	<b>6.05</b>

**P Mini-Filer Diamond Tip Set**

Includes a variety of filing tips coated with synthetic diamonds, precisely bonded to obtain the best physical properties for added strength and wear. These tips can be used in our Mini-Filer (see pp. 96 and 109) and other light-duty profiling handpieces. Total of 10 tips: four rectangular and four spatula tips (9.5mm coated length, grits 30, 50, 100 and 150); one 45° spatula tip (9mm coated length, grit 50); and one knife-edge tip (8mm coated length, grit 100). All measure .5mm thick x approx. 23mm long.

Description	Item#	Each
Mini-Filer Diamond Tip Set (includes 10 tips, stand and two tip holders 40mm and 80mm length)	<b>241-0600</b>	<b>\$169.00</b>

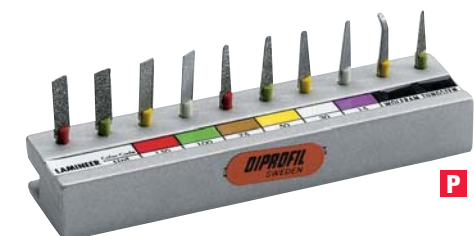

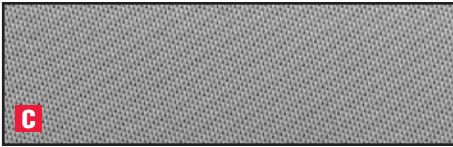
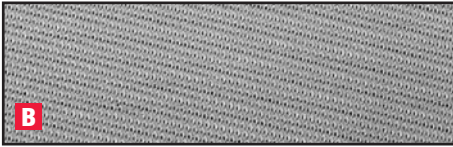
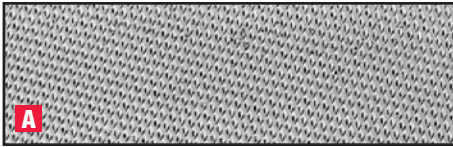

**Swiss Pattern Precision Files**

Each Swiss Pattern Precision File is measured in length from the point where the teeth cross to the end of the file. The Handle section (tang) is not considered in file length.

	Swiss Cut	=	American Cut
<b>A.</b>	00		Bastard
<b>B.</b>	0		Second
<b>C.</b>	2		Smooth

**Scale of Cuts for Swiss Pattern Precision Files\***

Teeth per Inch	Swiss Pattern File			Escapement 14cm	Needle 10 to 20cm	DS Rifflers 6" to 7"
	10"+	4" to 8"	3"			
30	00	-	-	-	-	-
41	0	00	-	-	-	-
51	1	0	00	-	-	-
64	2	1	0	0	0	0
79	3	2	1	-	-	-
97	4	3	2	2	2	2
117	-	4	3	3	3	3
142	6	-	4	4	4	4
173	-	6	-	-	-	-
213	-	-	6	6	6	6
295	-	-	-	8	-	-

*\*Except checkering pillar and checkering band files.*

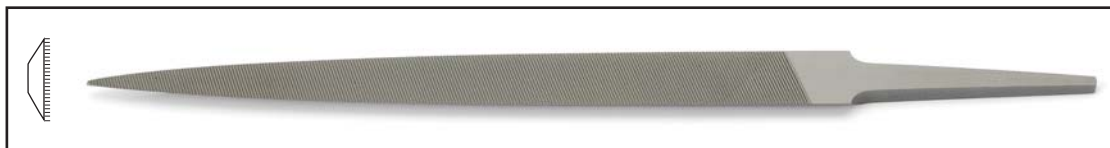

**Barrette**

Tapered in width and thickness, coming to a point. Only flat side is cut, providing safe edge and top.

Length of Cut	Width x Thickness	Cut	Item#	EACH Prices	
				1-11	12+
3"	2 <sup>3</sup> / <sub>64</sub> " x 3 <sup>3</sup> / <sub>32</sub> "	0	<b>735-0301</b>	<b>\$13.60</b>	<b>\$11.56</b>

Length of Cut	Width x Thickness	Cut	Item#	EACH Prices	
				1-11	12+
4"	1/2" x 1/8"	00	<b>735-0402</b>	<b>\$19.16</b>	<b>\$16.29</b>
		0	<b>735-0401</b>	<b>19.16</b>	<b>16.29</b>
		1	<b>735-0410</b>	<b>19.16</b>	<b>16.29</b>
		2	<b>735-0420</b>	<b>19.16</b>	<b>16.29</b>
		4	<b>735-0440</b>	<b>20.79</b>	<b>17.67</b>

Length of Cut	Width x Thickness	Cut	Item#	EACH Prices	
				1-11	12+
6"	2 <sup>3</sup> / <sub>32</sub> " x 5 <sup>3</sup> / <sub>32</sub> "	00	<b>735-0602</b>	<b>\$22.47</b>	<b>\$19.10</b>
		0	<b>735-0601</b>	<b>22.47</b>	<b>19.10</b>
		1	<b>735-0610</b>	<b>27.46</b>	<b>23.34</b>
		2	<b>735-0620</b>	<b>27.46</b>	<b>23.34</b>
		4	<b>735-0640</b>	<b>32.08</b>	<b>27.27</b>

Length of Cut	Width x Thickness	Cut	Item#	EACH Prices	
				1-11	12+
8"	7/8" x 1 <sup>3</sup> / <sub>64</sub> "	0	<b>735-0801</b>	<b>\$29.03</b>	<b>\$24.68</b>
		2	<b>735-0820</b>	<b>31.17</b>	<b>26.49</b>



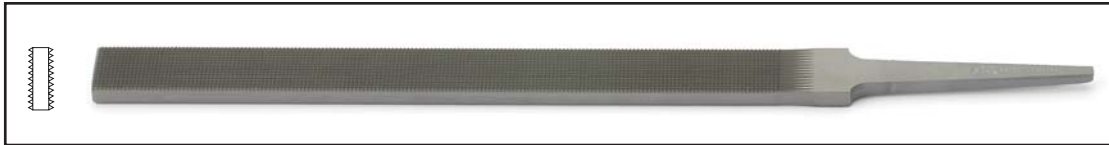

### Checkering Pillar

Parallel in width and gently tapered in thickness. Overcut is parallel to file edges, and upcut is 90° to overcut. Useful for putting serrations on knife edges or for obtaining a checkered design similar to that found on a gun handgrip.

Length of Cut	Width x Thickness	Lines per inch	Cut	Item#	EACH Prices	
					1-11	12+
6"	1/2" x 11/64"	20	00	<b>746-0602</b>	<b>\$33.81</b>	<b>\$28.74</b>
		30	0	<b>746-0601</b>	<b>24.41</b>	<b>20.75</b>
		50	2	<b>746-0620</b>	<b>35.96</b>	<b>30.57</b>
		75	4	<b>746-0640</b>	<b>39.27</b>	<b>33.38</b>

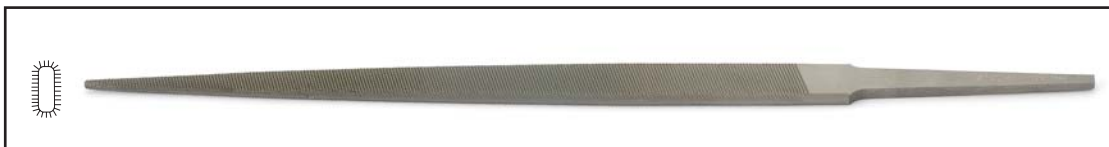

### Crochet

Tapered in width and gradually tapered in thickness. Used for filing junctions between flat and curved surfaces and for developing slots with rounded edges.

Length of Cut	Width x Thickness	Cut	Item#	EACH Prices	
				1-11	12+
4"	5/16" x 3/32"	2	<b>748-0420</b>	<b>\$15.33</b>	<b>\$13.03</b>

Length of Cut	Width x Thickness	Cut	Item#	EACH Prices	
				1-11	12+
				6"	13/32" x 9/64"
0	<b>748-0601</b>	<b>25.36</b>	<b>21.56</b>		
2	<b>748-0620</b>	<b>25.78</b>	<b>21.91</b>		



### File Card

Features steel wire bristles mounted on a wood handle for cleaning particles caught in teeth of files. Measures 8" long.

Description	Item#	EACH Prices	
		1-5	6+
File Card	<b>816-2800</b>	<b>\$5.90</b>	<b>\$4.72</b>

**Swiss Pattern Files, continued**

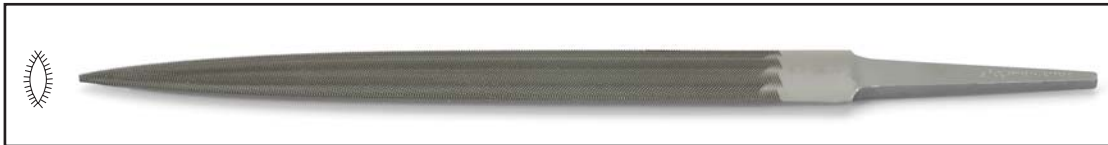

**Crossing**

Half-round on two sides with one side having a larger radius than the other. Tapered in width and thickness. Cut and usable to the point. Used primarily for filing interior curved surfaces. The double radius allows filing at the junction of two curved surfaces or of a straight and curved surface.

Length of Cut	Width x Thickness	Cut	Item#	EACH Prices	
				1-11	12+
4"	1 <sup>5</sup> / <sub>32</sub> " x <sup>9</sup> / <sub>64</sub> "	0	<b>742-0401</b>	<b>\$28.77</b>	<b>\$24.45</b>
		2	<b>742-0420</b>	<b>31.55</b>	<b>26.82</b>
		4	<b>742-0440</b>	<b>37.01</b>	<b>31.46</b>

Length of Cut	Width x Thickness	Cut	Item#	EACH Prices	
				1-11	12+
6"	1 <sup>9</sup> / <sub>32</sub> " x <sup>3</sup> / <sub>16</sub> "	0	<b>742-0601</b>	<b>\$38.33</b>	<b>\$32.58</b>
		2	<b>742-0620</b>	<b>42.79</b>	<b>36.37</b>
		4	<b>742-0640</b>	<b>51.66</b>	<b>43.91</b>



**Equalling**

Parallel in width and thickness. Used primarily for filing slots and corners.

Length of Cut	Width x Thickness	Cut	Item#	EACH Prices	
				1-11	12+
4"	1 <sup>3</sup> / <sub>32</sub> " x <sup>5</sup> / <sub>64</sub> "	0	<b>741-0401</b>	<b>\$20.63</b>	<b>\$17.54</b>
		2	<b>741-0420</b>	<b>16.12</b>	<b>13.70</b>
		4	<b>741-0440</b>	<b>18.38</b>	<b>15.62</b>

Length of Cut	Width x Thickness	Cut	Item#	EACH Prices	
				1-11	12+
6"	1/2" x <sup>7</sup> / <sub>64</sub> "	00	<b>741-0602</b>	<b>\$16.64</b>	<b>\$14.14</b>
		0	<b>741-0601</b>	<b>16.64</b>	<b>14.14</b>
		2	<b>741-0620</b>	<b>18.32</b>	<b>15.57</b>
		4	<b>741-0640</b>	<b>27.30</b>	<b>23.21</b>

Length of Cut	Width x Thickness	Cut	Item#	EACH Prices	
				1-11	12+
8"	2 <sup>1</sup> / <sub>32</sub> " x <sup>1</sup> / <sub>8</sub> "	00	<b>741-0802</b>	<b>\$24.57</b>	<b>\$20.88</b>
		0	<b>741-0801</b>	<b>24.57</b>	<b>20.88</b>
		2	<b>741-0820</b>	<b>24.57</b>	<b>20.88</b>



### Half-Round Slim

Tapered in width and thickness, coming to a point. Narrower than regular half-round so that it can be used for filing insides of holes. Cut on both sides.

Length of Cut	Width x Thickness	Cut	Item#	EACH Prices	
				1-11	12+
6"	1 <sup>5</sup> / <sub>32</sub> " x 9/ <sub>64</sub> "	00	<b>736-0602</b>	<b>\$26.62</b>	<b>\$22.63</b>
		0	<b>736-0601</b>	<b>26.62</b>	<b>22.63</b>
		1	<b>736-0610</b>	<b>29.30</b>	<b>24.91</b>
		2	<b>736-0620</b>	<b>29.30</b>	<b>24.91</b>
		3	<b>736-0630</b>	<b>34.11</b>	<b>28.99</b>
		4	<b>736-0640</b>	<b>36.91</b>	<b>31.37</b>



### Half-Round

Tapered in width and thickness, coming to a point. Cut on both sides.

Length of Cut	Width x Thickness	Cut	Item#	EACH Prices	
				1-11	12+
4"	1 <sup>5</sup> / <sub>32</sub> " x 9/ <sub>64</sub> "	00	<b>730-0402</b>	<b>\$21.16</b>	<b>\$17.99</b>
		0	<b>730-0401</b>	<b>21.16</b>	<b>17.99</b>
		2	<b>730-0420</b>	<b>23.15</b>	<b>19.68</b>
		3	<b>730-0430</b>	<b>25.25</b>	<b>21.46</b>
		4	<b>730-0440</b>	<b>25.25</b>	<b>21.46</b>

Length of Cut	Width x Thickness	Cut	Item#	EACH Prices	
				1-11	12+
6"	1 <sup>9</sup> / <sub>32</sub> " x 3/ <sub>16</sub> "	00	<b>730-0602</b>	<b>\$25.25</b>	<b>\$21.46</b>
		0	<b>730-0601</b>	<b>25.25</b>	<b>21.46</b>
		1	<b>730-0610</b>	<b>29.77</b>	<b>25.30</b>
		2	<b>730-0620</b>	<b>29.77</b>	<b>25.30</b>
		3	<b>730-0630</b>	<b>33.44</b>	<b>28.42</b>
		4	<b>730-0640</b>	<b>36.63</b>	<b>31.14</b>
		6	<b>730-0660</b>	<b>45.20</b>	<b>38.42</b>

Length of Cut	Width x Thickness	Cut	Item#	EACH Prices	
				1-11	12+
8"	1 <sup>3</sup> / <sub>16</sub> " x 5/ <sub>16</sub> "	00	<b>730-0802</b>	<b>\$35.91</b>	<b>\$30.52</b>
		0	<b>730-0801</b>	<b>35.86</b>	<b>30.48</b>
		1	<b>730-0810</b>	<b>40.62</b>	<b>34.53</b>
		2	<b>730-0820</b>	<b>40.62</b>	<b>34.53</b>
		4	<b>730-0840</b>	<b>47.15</b>	<b>40.08</b>

Length of Cut	Width x Thickness	Cut	Item#	EACH Prices	
				1-11	12+
10"	1" x 1 <sup>9</sup> / <sub>64</sub> "	0	<b>730-1001</b>	<b>\$47.15</b>	<b>\$40.08</b>

**Swiss Pattern Files, continued**



**Hand**

Parallel in width and tapered in thickness. One edge is safe.

Length of Cut	Width x Thickness	Cut	Item#	EACH Prices	
				1-11	12+
4"	1 <sup>7</sup> / <sub>32</sub> " x 1/8"	0	<b>731-0401</b>	<b>\$12.57</b>	<b>\$10.68</b>
		2	<b>731-0420</b>	<b>14.02</b>	<b>11.92</b>
		4	<b>731-0440</b>	<b>18.27</b>	<b>15.53</b>

Length of Cut	Width x Thickness	Cut	Item#	EACH Prices	
				1-11	12+
6"	3/4" x 5/32"	00	<b>731-0602</b>	<b>\$16.91</b>	<b>\$14.37</b>
		0	<b>731-0601</b>	<b>16.91</b>	<b>14.37</b>
		1	<b>731-0610</b>	<b>18.69</b>	<b>15.89</b>
		2	<b>731-0620</b>	<b>18.69</b>	<b>15.89</b>
		3	<b>731-0630</b>	<b>24.89</b>	<b>21.16</b>
		4	<b>731-0640</b>	<b>24.89</b>	<b>21.16</b>
6	<b>731-0660</b>	<b>32.87</b>	<b>27.94</b>		

Length of Cut	Width x Thickness	Cut	Item#	EACH Prices	
				1-11	12+
8"	2 <sup>9</sup> / <sub>32</sub> " x 3/16"	00	<b>731-0802</b>	<b>\$24.20</b>	<b>\$20.57</b>
		0	<b>731-0801</b>	<b>24.20</b>	<b>20.57</b>
		2	<b>731-0820</b>	<b>26.20</b>	<b>22.27</b>
		4	<b>731-0840</b>	<b>32.45</b>	<b>27.58</b>

Length of Cut	Width x Thickness	Cut	Item#	EACH Prices	
				1-11	12+
10"	1" x 1/4"	00	<b>731-1002</b>	<b>\$34.81</b>	<b>\$29.59</b>
		0	<b>731-1001</b>	<b>34.81</b>	<b>29.59</b>
		2	<b>731-1020</b>	<b>38.06</b>	<b>32.35</b>



**Knife-Edge**

Tapered in width and thickness, but the knife edge has the same thickness from point to shoulder. The included angle of the sharp edge is approximately 10°. Generally used to file in a slot or wedge-shaped opening. Curved knife edge allows easy filing in restricted areas.

Length of Cut	Width x Thickness	Cut	Item#	EACH Prices	
				1-11	12+
4"	1 <sup>5</sup> / <sub>32</sub> " x 1/8"	00	<b>745-0402</b>	<b>\$18.06</b>	<b>\$15.35</b>
		0	<b>745-0401</b>	<b>18.06</b>	<b>15.35</b>
		1	<b>745-0410</b>	<b>19.74</b>	<b>16.78</b>
		2	<b>745-0420</b>	<b>19.79</b>	<b>16.82</b>
		4	<b>745-0440</b>	<b>22.26</b>	<b>18.92</b>

Length of Cut	Width x Thickness	Cut	Item#	EACH Prices	
				1-11	12+
6"	2 <sup>3</sup> / <sub>32</sub> " x 5/32"	00	<b>745-0602</b>	<b>\$22.26</b>	<b>\$18.92</b>
		0	<b>745-0601</b>	<b>22.26</b>	<b>18.92</b>
		2	<b>745-0620</b>	<b>28.61</b>	<b>24.32</b>
		4	<b>745-0640</b>	<b>33.86</b>	<b>28.78</b>





### Pillar, Demi-Narrow

Parallel in width and tapered in thickness. Cut on the flat sides only.

Length of Cut	Width x Thickness	Cut	Item#	EACH Prices	
				1-11	12+
6"	3/8" x 5/32"	00	<b>738-0602</b>	<b>\$42.40</b>	<b>\$36.04</b>
		0	<b>738-0601</b>	<b>46.20</b>	<b>39.27</b>
		1	<b>738-0610</b>	<b>33.10</b>	<b>28.14</b>
		2	<b>738-0620</b>	<b>35.85</b>	<b>30.47</b>

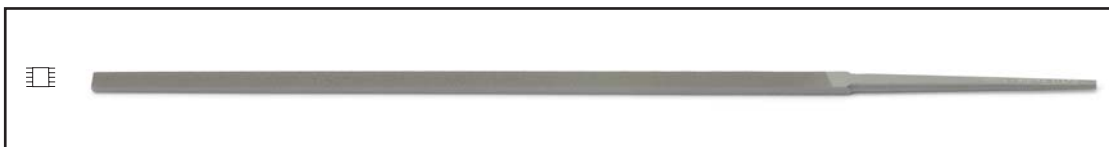

### Pillar, Extra-Narrow

Parallel in width and tapered in thickness. Cut on the flat sides only.

Length of Cut	Width x Thickness	Cut	Item#	EACH Prices	
				1-11	12+
3"	1/8" x 5/64"	2	<b>740-0320</b>	<b>\$12.02</b>	<b>\$10.22</b>

Length of Cut	Width x Thickness	Cut	Item#	EACH Prices	
				1-11	12+
4"	5/32" x 5/64"	00	<b>740-0402</b>	<b>\$12.02</b>	<b>\$10.22</b>
		0	<b>740-0401</b>	<b>12.02</b>	<b>10.22</b>
		2	<b>740-0420</b>	<b>13.34</b>	<b>11.34</b>
		4	<b>740-0440</b>	<b>16.38</b>	<b>13.92</b>

Length of Cut	Width x Thickness	Cut	Item#	EACH Prices	
				1-11	12+
6"	13/64" x 1/8"	00	<b>740-0602</b>	<b>\$13.86</b>	<b>\$11.78</b>
		0	<b>740-0601</b>	<b>13.86</b>	<b>11.78</b>
		1	<b>740-0610</b>	<b>14.18</b>	<b>12.05</b>
		2	<b>740-0620</b>	<b>14.18</b>	<b>12.05</b>
		4	<b>740-0640</b>	<b>17.90</b>	<b>15.22</b>
		6	<b>740-0660</b>	<b>27.56</b>	<b>23.43</b>

Length of Cut	Width x Thickness	Cut	Item#	EACH Prices	
				1-11	12+
8"	9/32" x 9/64"	00	<b>740-0802</b>	<b>\$18.43</b>	<b>\$15.67</b>
		0	<b>740-0801</b>	<b>18.43</b>	<b>15.67</b>
		2	<b>740-0820</b>	<b>24.57</b>	<b>20.88</b>

**Swiss Pattern Files, continued**



**Pillar, Narrow**

Parallel in width and tapered in thickness. Cut on the flat sides only.

Length of Cut	Width x Thickness	Cut	Item#	EACH Prices	
				1-11	12+
4"	3/16" x 3/32"	00	<b>739-0402</b>	<b>\$13.76</b>	<b>\$11.70</b>
		0	<b>739-0401</b>	<b>13.76</b>	<b>11.70</b>
		2	<b>739-0420</b>	<b>13.76</b>	<b>11.70</b>
		4	<b>739-0440</b>	<b>17.27</b>	<b>14.68</b>

Length of Cut	Width x Thickness	Cut	Item#	EACH Prices	
				1-11	12+
6"	1/4" x 9/64"	00	<b>739-0602</b>	<b>\$13.86</b>	<b>\$11.78</b>
		0	<b>739-0601</b>	<b>13.86</b>	<b>11.78</b>
		1	<b>739-0610</b>	<b>13.86</b>	<b>11.78</b>
		2	<b>739-0620</b>	<b>14.28</b>	<b>12.14</b>
		4	<b>739-0640</b>	<b>17.90</b>	<b>15.22</b>
		6	<b>739-0660</b>	<b>27.56</b>	<b>23.43</b>

Length of Cut	Width x Thickness	Cut	Item#	EACH Prices	
				1-11	12+
8"	11/32" x 11/64"	0	<b>739-0801</b>	<b>\$18.43</b>	<b>\$15.67</b>
		2	<b>739-0820</b>	<b>19.69</b>	<b>16.74</b>

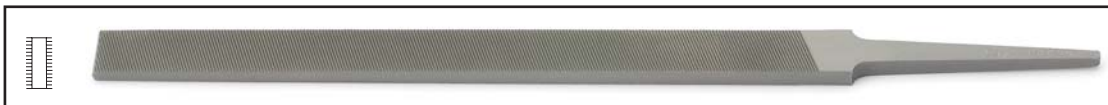

**Pillar, Regular**

A general-purpose file used primarily for working on flat surfaces. Because pillar files are available in various widths, they are adaptable to filing in slots, keyways, splines and similar areas. Parallel in width and tapered in thickness to provide perfectly flat filing.

Length of Cut	Width x Thickness	Cut	Item#	EACH Prices	
				1-11	12+
4"	3/8" x 1/8"	00	<b>737-0402</b>	<b>\$12.08</b>	<b>\$10.27</b>
		0	<b>737-0401</b>	<b>12.08</b>	<b>10.27</b>
		2	<b>737-0420</b>	<b>13.70</b>	<b>11.65</b>
		6	<b>737-0440</b>	<b>14.91</b>	<b>12.67</b>

Length of Cut	Width x Thickness	Cut	Item#	EACH Prices	
				1-11	12+
6"	1/2" x 11/64"	00	<b>737-0602</b>	<b>\$13.81</b>	<b>\$11.74</b>
		0	<b>737-0601</b>	<b>13.81</b>	<b>11.74</b>
		1	<b>737-0610</b>	<b>14.18</b>	<b>12.05</b>
		2	<b>737-0620</b>	<b>14.07</b>	<b>11.96</b>
		4	<b>737-0630</b>	<b>16.43</b>	<b>13.97</b>
		6	<b>737-0640</b>	<b>17.96</b>	<b>15.27</b>

Length of Cut	Width x Thickness	Cut	Item#	EACH Prices	
				1-11	12+
8"	19/32" x 13/64"	0	<b>737-0801</b>	<b>\$18.38</b>	<b>\$15.62</b>
		2	<b>737-0820</b>	<b>19.58</b>	<b>16.64</b>

Length of Cut	Width x Thickness	Cut	Item#	EACH Prices	
				1-11	12+
10"	23/32" x 15/64"	00	<b>737-1002</b>	<b>\$25.15</b>	<b>\$21.38</b>
		0	<b>737-1001</b>	<b>25.15</b>	<b>21.38</b>
		2	<b>737-1020</b>	<b>27.46</b>	<b>23.34</b>



### Pippin

Tapered in width and thickness. Combines the cross sections of round and crossing files with the edge of a knife file. For finishing the junction of two different curved surfaces and for opening slots when a "V" shape is required.

Length of Cut	Width x Thickness	Cut	Item#	EACH Prices	
				1-11	12+
6"	2 <sup>5</sup> / <sub>64</sub> " x 9/ <sub>64</sub> "	0	<b>747-0601</b>	<b>\$40.11</b>	<b>\$34.09</b>
		2	<b>747-0620</b>	<b>39.17</b>	<b>33.29</b>

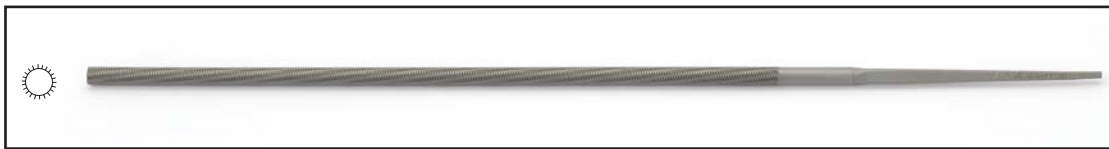

### Round, Parallel

Cut over the entire surface. The 4" length is available in 1/16" and 1/8" diameters. The 6" length is available in 3/32", 1/8", 5/32" and 3/16" diameters.

Length of Cut	Diameter	Cut	Item#	EACH Prices	
				1-11	12+
4"	1/16"	0	<b>733-4501</b>	<b>\$13.43</b>	<b>\$11.42</b>
		2	<b>733-4520</b>	<b>13.81</b>	<b>11.74</b>

Length of Cut	Diameter	Cut	Item#	EACH Prices	
				1-11	12+
4"	1/8"	0	<b>733-4401</b>	<b>\$21.95</b>	<b>\$18.66</b>

Length of Cut	Diameter	Cut	Item#	EACH Prices	
				1-11	12+
6"	3/32"	0	<b>733-3601</b>	<b>\$20.63</b>	<b>\$17.54</b>
		2	<b>733-3620</b>	<b>21.42</b>	<b>18.21</b>

Length of Cut	Diameter	Cut	Item#	EACH Prices	
				1-11	12+
6"	1/8"	0	<b>733-4601</b>	<b>\$20.63</b>	<b>\$17.54</b>
		2	<b>733-4620</b>	<b>21.42</b>	<b>18.21</b>

Length of Cut	Diameter	Cut	Item#	EACH Prices	
				1-11	12+
				6"	5/32"
0	<b>733-5601</b>	<b>20.63</b>	<b>17.54</b>		
2	<b>733-5620</b>	<b>22.05</b>	<b>18.74</b>		

Length of Cut	Diameter	Cut	Item#	EACH Prices	
				1-11	12+
				6"	3/16"
0	<b>733-6601</b>	<b>20.63</b>	<b>17.54</b>		
2	<b>733-6620</b>	<b>18.95</b>	<b>16.11</b>		

## Swiss Pattern Files, continued



### Round, Tapered

Gradually tapered. Cut and workable to the point. Used where it is necessary to enlarge a hole or round off a radius.

Length of Cut	Diameter	Cut	Item#	EACH Prices	
				1-11	12+
4"	5/32"	00	<b>732-0402</b>	<b>\$12.60</b>	<b>\$10.71</b>
		1	<b>732-0410</b>	<b>13.13</b>	<b>11.16</b>
		2	<b>732-0420</b>	<b>13.07</b>	<b>11.11</b>
		4	<b>732-0440</b>	<b>14.91</b>	<b>12.67</b>

Length of Cut	Diameter	Cut	Item#	EACH Prices	
				1-11	12+
6"	1/4"	00	<b>732-0602</b>	<b>\$14.49</b>	<b>\$12.32</b>
		0	<b>732-0601</b>	<b>14.49</b>	<b>12.32</b>
		2	<b>732-0620</b>	<b>15.91</b>	<b>13.52</b>
		3	<b>732-0630</b>	<b>15.91</b>	<b>13.52</b>
		4	<b>732-0640</b>	<b>18.90</b>	<b>16.07</b>
		6	<b>732-0660</b>	<b>19.64</b>	<b>16.69</b>

Length of Cut	Diameter	Cut	Item#	EACH Prices	
				1-11	12+
8"	5/16"	1	<b>732-0810</b>	<b>\$20.74</b>	<b>\$17.63</b>
		2	<b>732-0820</b>	<b>22.21</b>	<b>18.88</b>



### Square

Gradually tapered and cut on all four sides. Cut and usable to the point. A general-purpose file.

Length of Cut	Size	Cut	Item#	EACH Prices	
				1-11	12+
4"	5/32"	0	<b>743-0401</b>	<b>\$15.38</b>	<b>\$13.07</b>
		1	<b>743-0410</b>	<b>15.38</b>	<b>13.07</b>
		2	<b>743-0420</b>	<b>15.38</b>	<b>13.07</b>

Length of Cut	Size	Cut	Item#	EACH Prices	
				1-11	12+
6"	15/64"	00	<b>743-0602</b>	<b>\$20.32</b>	<b>\$17.27</b>
		0	<b>743-0601</b>	<b>20.32</b>	<b>17.27</b>
		1	<b>743-0610</b>	<b>20.63</b>	<b>17.54</b>
		2	<b>743-0620</b>	<b>20.63</b>	<b>17.54</b>
		4	<b>743-0640</b>	<b>22.52</b>	<b>19.14</b>

Length of Cut	Size	Cut	Item#	EACH Prices	
				1-11	12+
8"	5/16"	00	<b>743-0802</b>	<b>\$22.52</b>	<b>\$19.14</b>
		0	<b>743-0801</b>	<b>22.52</b>	<b>19.14</b>
		2	<b>743-0820</b>	<b>26.20</b>	<b>22.27</b>





### Three-Square

Gradually tapered and cut to the point.

Length of Cut	Size	Cut	Item#	EACH Prices	
				1-11	12+
4"	9/32"	1	<b>734-0410</b>	<b>\$17.75</b>	<b>\$15.09</b>
		2	<b>734-0420</b>	<b>17.75</b>	<b>15.09</b>
		4	<b>734-0440</b>	<b>20.48</b>	<b>17.41</b>

Length of Cut	Size	Cut	Item#	EACH Prices	
				1-11	12+
6"	3/8"	0	<b>734-0601</b>	<b>\$17.69</b>	<b>\$15.04</b>
		1	<b>734-0610</b>	<b>18.22</b>	<b>15.49</b>
		2	<b>734-0620</b>	<b>18.22</b>	<b>15.49</b>
		4	<b>734-0640</b>	<b>25.46</b>	<b>21.64</b>

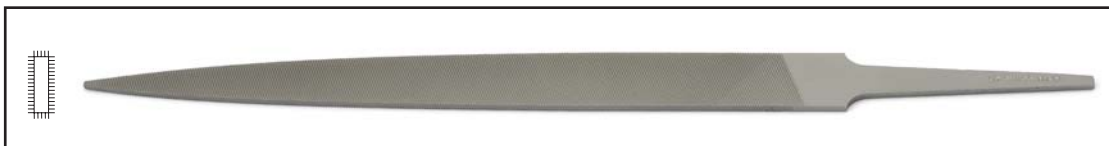

### Warding

Parallel in thickness and tapered in width. Good for deburring.

Length of Cut	Width x Thickness	Cut	Item#	EACH Prices	
				1-11	12+
4"	1/2" x 3/64"	00	<b>749-0402</b>	<b>\$12.65</b>	<b>\$10.75</b>
		0	<b>749-0401</b>	<b>12.65</b>	<b>10.75</b>
		2	<b>749-0420</b>	<b>14.91</b>	<b>12.67</b>
		4	<b>749-0440</b>	<b>21.68</b>	<b>18.43</b>

Length of Cut	Width x Thickness	Cut	Item#	EACH Prices	
				1-11	12+
6"	5/8" x 5/64"	00	<b>749-0602</b>	<b>\$18.22</b>	<b>\$15.49</b>
		0	<b>749-0601</b>	<b>18.22</b>	<b>15.49</b>
		2	<b>749-0620</b>	<b>20.84</b>	<b>17.71</b>
		4	<b>749-0640</b>	<b>26.36</b>	<b>22.41</b>

Length of Cut	Width x Thickness	Cut	Item#	EACH Prices	
				1-11	12+
8"	7/8" x 7/64"	0	<b>749-0801</b>	<b>\$24.62</b>	<b>\$20.93</b>

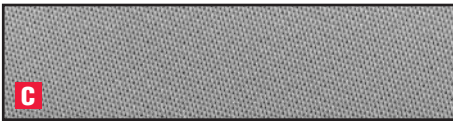
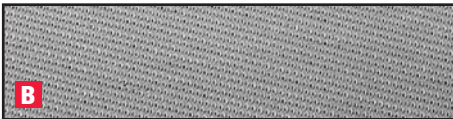
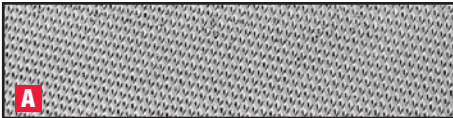

## American Pattern Files

For jobs that do not require the accuracy of Swiss Precision Files, American Pattern Files provide the best results. Uniform in cut to permit removal of more metal faster. Handle section (tang) is not considered in file length.

	American Cut	=	Swiss Cut
<b>A.</b>	Bastard		00
<b>B.</b>	Second		0
<b>C.</b>	Smooth		2



### Flat (End Tapered)

Universally used by all machinists, this file is recommended for fast stock removal where a smooth finish is not required. In addition to being double cut, it differs from the mill file in that it has a thicker cross section.

Length of Cut	Width x Thickness	Cut	Item#	EACH Prices	
				1-11	12+
6"	5/8" x 5/32"	Bastard	<b>770-0627</b>	<b>\$5.25</b>	<b>\$4.46</b>
		Second	<b>770-0628</b>	<b>5.58</b>	<b>4.74</b>
		Smooth	<b>770-0629</b>	<b>6.66</b>	<b>5.66</b>
8"	25/32" x 7/32"	Bastard	<b>770-0827</b>	<b>6.52</b>	<b>5.54</b>
		Second	<b>770-0828</b>	<b>7.21</b>	<b>6.13</b>
		Smooth	<b>770-0829</b>	<b>7.76</b>	<b>6.60</b>
10"	31/32" x 5/32"	Bastard	<b>770-1027</b>	<b>8.14</b>	<b>6.92</b>
		Second	<b>770-1028</b>	<b>9.31</b>	<b>7.91</b>
		Smooth	<b>770-1029</b>	<b>10.20</b>	<b>8.67</b>
12"	15/32" x 9/32"	Bastard	<b>770-1227</b>	<b>11.07</b>	<b>9.41</b>
		Second	<b>770-1228</b>	<b>12.54</b>	<b>10.66</b>
		Smooth	<b>770-1229</b>	<b>13.86</b>	<b>11.78</b>

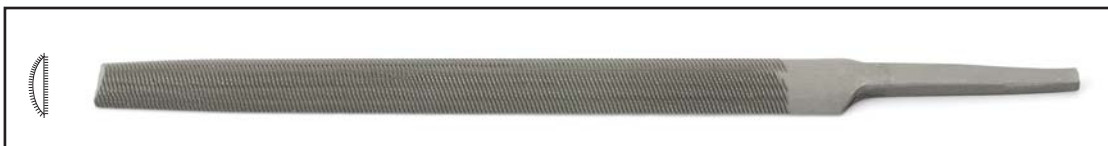

### Half-Round

In addition to being widely used by machinists, this file is also popular in foundries where castings must be finished by filing. Rounded to approximately a third of a round on one side and double cut flat on the other. The round side is double cut as well except on all smooth and 6" second cut, which are single cut.

Length of Cut	Width x Thickness	Cut	Item#	EACH Prices	
				1-11	12+
6"	19/32" x 5/32"	Bastard	<b>770-0667</b>	<b>\$7.71</b>	<b>\$6.55</b>
		Second	<b>770-0668</b>	<b>8.79</b>	<b>7.47</b>
		Smooth	<b>770-0669</b>	<b>9.08</b>	<b>7.72</b>
8"	3/4" x 7/32"	Bastard	<b>770-0867</b>	<b>9.31</b>	<b>7.91</b>
		Second	<b>770-0868</b>	<b>10.34</b>	<b>8.79</b>
		Smooth	<b>770-0869</b>	<b>11.07</b>	<b>9.41</b>
10"	15/16" x 9/32"	Bastard	<b>770-1067</b>	<b>11.61</b>	<b>9.87</b>
		Second	<b>770-1068</b>	<b>12.63</b>	<b>10.74</b>
		Smooth	<b>770-1069</b>	<b>13.21</b>	<b>11.23</b>
12"	15/32" x 9/32"	Bastard	<b>770-1267</b>	<b>14.87</b>	<b>12.64</b>
		Second	<b>770-1268</b>	<b>16.25</b>	<b>13.81</b>
		Smooth	<b>770-1269</b>	<b>17.11</b>	<b>14.54</b>



### Hand

Similar to a flat file but tapered in thickness with one safe edge. This uncut edge allows filing of one surface without damaging an adjoining surface.

Length of Cut	Width x Thickness	Cut	Item#	EACH Prices	
				1-11	12+
6"	5/8" x 5/32"	Smooth	<b>770-0639</b>	<b>\$5.95</b>	<b>\$5.36</b>
8"	25/32" x 7/32"	Bastard	<b>770-0837</b>	<b>6.10</b>	<b>5.49</b>
		Second	<b>770-0838</b>	<b>6.90</b>	<b>6.21</b>
		Smooth	<b>770-0839</b>	<b>6.95</b>	<b>6.26</b>
10"	31/32" x 1/4"	Bastard	<b>770-1037</b>	<b>8.45</b>	<b>7.61</b>
		Second	<b>770-1038</b>	<b>8.95</b>	<b>8.06</b>
		Smooth	<b>770-1039</b>	<b>9.45</b>	<b>8.51</b>



### Mill

Used in machine shops as a general-purpose file and for draw filing, lathe work and finishing operations on hard materials. Often used in conjunction with a flat or hand file as a finishing file after the "hogging off" operation.

Length of Cut	Width x Thickness	Cut	Item#	EACH Prices	
				1-11	12+
6"	5/8" x 5/32"	Bastard	<b>770-0617</b>	<b>\$3.95</b>	<b>\$3.36</b>
		Second	<b>770-0618</b>	<b>5.47</b>	<b>4.65</b>
		Smooth	<b>770-0619</b>	<b>5.72</b>	<b>4.86</b>
8"	25/32" x 7/32"	Bastard	<b>770-0817</b>	<b>4.63</b>	<b>3.94</b>
		Second	<b>770-0818</b>	<b>6.09</b>	<b>5.18</b>
		Smooth	<b>770-0819</b>	<b>6.77</b>	<b>5.75</b>
10"	31/32" x 1/4"	Bastard	<b>770-1017</b>	<b>6.01</b>	<b>5.11</b>
		Second	<b>770-1018</b>	<b>7.79</b>	<b>6.62</b>
		Smooth	<b>770-1019</b>	<b>8.31</b>	<b>7.06</b>
12"	15/32" x 7/32"	Bastard	<b>770-1217</b>	<b>9.86</b>	<b>8.38</b>
		Second	<b>770-1218</b>	<b>10.26</b>	<b>8.72</b>
		Smooth	<b>770-1219</b>	<b>11.28</b>	<b>9.59</b>



### Round

Designed for filing concave surfaces that have a smaller radius than a half-round file, enlarging round holes and making a corner radius.

Length of Cut	Diameter	Cut	Item#	EACH Prices	
				1-11	12+
6"	7/32"	Bastard	<b>770-0677</b>	<b>\$4.31</b>	<b>\$3.66</b>
		Second	<b>770-0678</b>	<b>4.95</b>	<b>4.21</b>
		Smooth	<b>770-0679</b>	<b>5.42</b>	<b>4.61</b>
8"	5/16"	Bastard	<b>770-0877</b>	<b>4.98</b>	<b>4.23</b>
		Second	<b>770-0878</b>	<b>5.79</b>	<b>4.92</b>
		Smooth	<b>770-0879</b>	<b>6.44</b>	<b>5.47</b>
10"	3/8"	Bastard	<b>770-1077</b>	<b>6.44</b>	<b>5.47</b>
		Second	<b>770-1078</b>	<b>7.61</b>	<b>6.47</b>
		Smooth	<b>770-1079</b>	<b>8.36</b>	<b>7.11</b>
12"	1/2"	Bastard	<b>770-1277</b>	<b>8.91</b>	<b>7.57</b>
		Second	<b>770-1278</b>	<b>10.16</b>	<b>8.64</b>
		Smooth	<b>770-1279</b>	<b>11.07</b>	<b>9.41</b>

## American Pattern Files, continued

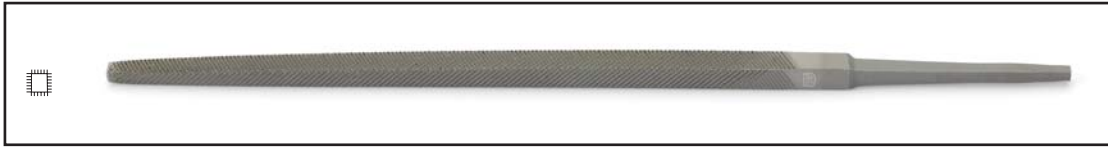

### Square

Perfectly square tapering toward the point. Used for enlarging slots, keyways, grooves and holes that have right angles and for filing flat surfaces.

Length of Cut	Width	Cut	Item#	EACH Prices	
				1-11	12+
6"	7/32"	Bastard	<b>770-0647</b>	<b>\$5.71</b>	<b>\$4.85</b>
		Second	<b>770-0648</b>	<b>6.44</b>	<b>5.47</b>
		Smooth	<b>770-0649</b>	<b>6.77</b>	<b>5.75</b>
8"	5/16"	Bastard	<b>770-0847</b>	<b>6.77</b>	<b>5.75</b>
		Second	<b>770-0848</b>	<b>7.65</b>	<b>6.50</b>
		Smooth	<b>770-0849</b>	<b>8.44</b>	<b>7.17</b>
10"	3/8"	Bastard	<b>770-1047</b>	<b>8.94</b>	<b>7.60</b>
		Second	<b>770-1048</b>	<b>10.31</b>	<b>8.76</b>
		Smooth	<b>770-1049</b>	<b>11.03</b>	<b>9.38</b>
12"	1/2"	Bastard	<b>770-1247</b>	<b>12.71</b>	<b>10.80</b>
		Second	<b>770-1248</b>	<b>14.19</b>	<b>12.06</b>
		Smooth	<b>770-1249</b>	<b>15.64</b>	<b>13.29</b>

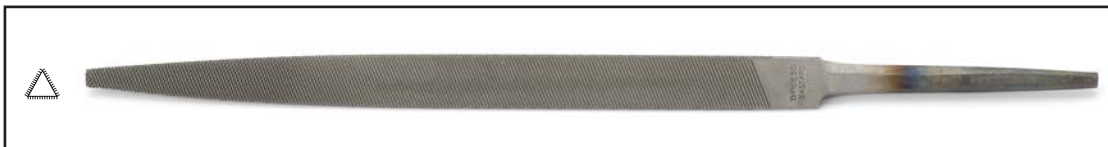

### Three-Square

Triangular double cut file. Tapers toward the point and has sharp corners. Used to file acute internal angles that cannot be reached with rectangular files.

Length of Cut	Width	Cut	Item#	EACH Prices	
				1-11	12+
6"	7/32"	Bastard	<b>770-0657</b>	<b>\$6.96</b>	<b>\$5.92</b>
		Second	<b>770-0658</b>	<b>8.24</b>	<b>7.00</b>
		Smooth	<b>770-0659</b>	<b>8.35</b>	<b>7.10</b>
8"	5/16"	Bastard	<b>770-0857</b>	<b>8.75</b>	<b>7.44</b>
		Second	<b>770-0858</b>	<b>9.74</b>	<b>8.28</b>
		Smooth	<b>770-0859</b>	<b>10.40</b>	<b>8.84</b>
10"	3/4"	Bastard	<b>770-1057</b>	<b>10.87</b>	<b>9.24</b>
		Second	<b>770-1058</b>	<b>11.80</b>	<b>10.03</b>
		Smooth	<b>770-1059</b>	<b>12.46</b>	<b>10.59</b>



### **A** Utility File Set

**Six files to match any job perfectly!**

Includes six American Pattern Files with wooden handles: square, half-round, three-square, round, flat and warding, all smooth cut. Comes complete with hanging pouch. Files measure 7" long with approx. 4" cut length.

Description	Item#	Each
Utility File Set	<b>705-1005</b>	<b>\$14.10</b>



**A - E Grobet File Handles**

Unbreakable plastic handles shaped to fit your hand comfortably and textured to prevent slipping. Feature high-quality tempered metal tong-holding inserts that are threaded to ensure proper alignment and positive grip. Allow easy file changes: just unscrew the file in use and screw in another. Have holes at top for hanging near your workbench.

Style	Item#	EACH Prices	
		1-11	12+
<b>A. 2</b>	<b>170-6002</b>	<b>\$2.95</b>	<b>\$2.66</b>
<b>B. 3</b>	<b>170-6003</b>	<b>2.95</b>	<b>2.66</b>
<b>C. 4</b>	<b>170-6004</b>	<b>2.85</b>	<b>2.57</b>
<b>D. 5</b>	<b>170-6005</b>	<b>2.85</b>	<b>2.57</b>
<b>E. 6</b>	<b>170-6006</b>	<b>3.10</b>	<b>2.79</b>

**Handle Selection Guide**

File Shape	File Length					
	3"	4"	6"	8"	10"	12"
Barrette	2	3	4	5	-	-
Checkering	-	-	4	-	-	-
Crochet	-	3	4	5	-	-
Crossing	-	3	4	5	-	-
Equalling	-	3	4	5	-	-
Half-Round	-	3	4	5	6	6
Hand	-	3	4	5	6	6
Knife-Edge	-	3	4	5	6	6
Pillar	2	3	4	5	6	6
Pippin	-	3	4	5	-	-
Round, Parallel	-	-	2	3	-	-
Round, Pointed	-	2	3	4	5	-
Slitting	-	3	4	-	-	-
Square	-	2	3	4	5	-
Three-Square	2	3	4	5	6	6
Warding	-	3	4	5	-	-



**F Ergonomic File Handle**

Keeps the file's axis aligned with the forearm, significantly reducing muscle fatigue. Allows user to rotate arm slightly to change the file angle while still applying enough working pressure. Fits comfortably in the palm of your hand. Made of aluminum with grooved, soft rubber nonslip grip. Holds 6" to 8" files securely with easily accessible internal screws. Measures 5" long.

Description	Item#	Each
Ergonomic File Handle	<b>170-3000</b>	<b>\$16.20</b>



**G Plastic Needle File Handle**

Durable plastic handle for holding all needle files and most single-ended rifflers. Measures 3 1/4" long.

Description	Item#	EACH Prices	
		1-11	12+
Plastic File Handle	<b>170-4010</b>	<b>\$4.45</b>	<b>\$3.78</b>



**H Wood File Handle with Collet**

Polished wood handle with metal collet for needle files, escapement files and other small tools. Measures 4 1/2" long including collet.

Description	Item#	Each
Wood File Handle	<b>170-4013</b>	<b>\$3.98</b>



**I - M Wood File Handles with Ferrules**

Polished wood handles with metal ferrules for holding large files and needle files. Easy to attach: fix the file in a vise with its tang pointing up, place the starter hole in the handle over the file tang, and tap the handle with a rawhide mallet to push it onto the tang. Use needle file handles for escapement files, needle files and other small tools, and use large file handles for Swiss Pattern Precision Files and American Pattern Files. Handle lengths listed below include ferrules.

Description	Length	Item#	EACH Prices		
			1-2	3-9	10+
<b>I. Needle File Handle</b>	3 1/2"	<b>170-4011</b>	<b>\$.89</b>	<b>\$.85</b>	<b>\$.80</b>
<b>J.</b>	4"	<b>170-4012</b>	<b>.89</b>	<b>.85</b>	<b>.80</b>
<b>K. Large File Handle</b>	3"	<b>170-6012</b>	<b>1.95</b>	<b>1.85</b>	<b>1.76</b>
<b>L.</b>	4"	<b>170-6013</b>	<b>1.95</b>	<b>1.85</b>	<b>1.76</b>
<b>M.</b>	5"	<b>170-6014</b>	<b>2.10</b>	<b>2.00</b>	<b>1.89</b>



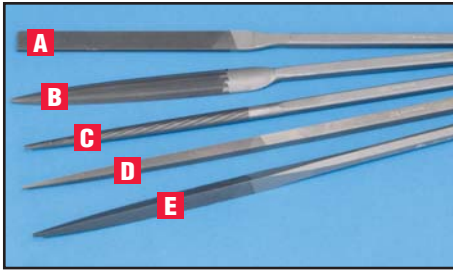

**A - E Habilis™ Swiss Files**

Habilis files are designed for those in-between jobs that are too big for needle files and require finer control than heavier files. Shaped for easy handling and balanced for efficient cutting. Feature strong, secure built-in handles. Available in five different shapes for practically every precision filing requirement. Measure 8½" long with 4" cut length. All double cut. Made in Switzerland.

Style	Shape	Cut 00 Item#	Cut 1 Item#	EACH Prices	
				1-9	10+*
A. Square		<b>704-1030</b>	<b>704-1031</b>	<b>\$8.75</b>	<b>\$7.88</b>
B. Round		<b>704-1040</b>	<b>704-1041</b>	<b>8.75</b>	<b>7.88</b>
C. Half-Round		<b>704-1010</b>	<b>704-1011</b>	<b>15.30</b>	<b>13.77</b>
D. Hand		<b>704-1000</b>	<b>704-1001</b>	<b>11.05</b>	<b>9.95</b>
E. Three-Square		<b>704-1020</b>	<b>704-1021</b>	<b>12.15</b>	<b>10.94</b>
5-Piece Set (one of each)		<b>704-2000</b>	<b>704-2001</b>	<b>54.75</b>	<b>-</b>

\*Quantity discount for orders of one item# only, not assorted.



**F Swiss Vulcanite File**

High-quality half-round Swiss file with open teeth for filing and shaping plastic and other soft materials. Double ended: one coarse cut, the other medium cut. Each end is ½" wide tapering to tip. Measures 8" long.

Description	Item#	Each
Vulcanite File	<b>704-0010</b>	<b>\$34.65</b>

**G Screwhead File with Tang**

Used for filing .022" slots in small screws. Measures 4½"L x 25/64"W x .022" thick, with 27/8" cut length.

Description	Item#	EACH Prices	
		1-11	12+
Screwhead File	<b>749-1000</b>	<b>\$24.87</b>	<b>\$21.14</b>

**H - K Steel Files – For reciprocating handpieces.**

High-quality steel files for reciprocating handpieces. All cut 0. Measure 80mm (3<sup>3</sup>/<sub>16</sub>") long with 3mm shanks.

Style	Shape	Item#	Each
H. Round		<b>701-0500</b>	<b>\$9.95</b>
I. Equalling		<b>701-0520</b>	<b>9.95</b>
J. Half-Round		<b>701-0540</b>	<b>9.95</b>
K. Three-Square		<b>701-0560</b>	<b>9.95</b>

**L - Q Valtitan Needle Files – For hard metals.**

Valtitan files provide excellent performance on hard-to-file surfaces and hard metals. Feature exceptional hardness of 72 HRC and corrosion resistance for long life. Best of all, they won't clog—one knock is enough to remove metal chips. Handles are yellow for quick identification. Measure approx. 6½" long. Made in Switzerland.

Style	Shape	Cut 0 Item#	Cut 2 Item#	EACH Prices		
				1-2	3-11*	10+*
L. Equalling		<b>702-0021</b>	<b>702-0022</b>	<b>\$10.50</b>	<b>\$9.98</b>	<b>\$9.45</b>
M. Half-Round		<b>702-0026</b>	<b>702-0027</b>	<b>10.50</b>	<b>9.98</b>	<b>9.45</b>
N. Three-Square		<b>702-0031</b>	<b>702-0032</b>	<b>10.50</b>	<b>9.98</b>	<b>9.45</b>
O. Square		<b>702-0036</b>	<b>702-0037</b>	<b>10.50</b>	<b>9.98</b>	<b>9.45</b>
P. Round		<b>702-0041</b>	<b>702-0042</b>	<b>10.50</b>	<b>9.98</b>	<b>9.45</b>
Q. Barrette		<b>702-0046</b>	<b>702-0047</b>	<b>10.50</b>	<b>9.98</b>	<b>9.45</b>
6-Piece Set (one of each)		<b>702-0051</b>	<b>702-0052</b>	<b>59.50</b>	<b>-</b>	<b>-</b>

\*Quantity discount for orders of one item# only, not assorted.

### Swiss Needle Files with Round Knurled Handles

Used for precision filing of small areas and for miniature work. The finest quality files made. Teeth are sharp and cross cut, ensuring even filing. Handles are knurled to provide a sure grip. Length measurements include handle.

Overall Length	Cut Length
4" (10cm)	1½"
5½" (14cm)	2½"
6¼" (16cm)	3"
7¾" (20cm)	4⅛"



#### Barrette

Tapered in width and thickness, coming to a point. Only flat side is cut, providing safe edge and top.

Length		Cut	Item#	EACH Prices	
inches	cm			1-11	12+
4	10	0	<b>705-1020</b>	<b>\$10.29</b>	<b>\$8.75</b>
		2	<b>705-1022</b>	<b>10.29</b>	<b>8.75</b>
		4	<b>705-1024</b>	<b>10.29</b>	<b>8.75</b>
5½	14	0	<b>710-1020</b>	<b>10.76</b>	<b>9.15</b>
		2	<b>710-1022</b>	<b>10.76</b>	<b>9.15</b>
		4	<b>710-1024</b>	<b>10.76</b>	<b>9.15</b>
6¼	16	00	<b>715-1029</b>	<b>11.54</b>	<b>9.81</b>
		0	<b>715-1020</b>	<b>11.54</b>	<b>9.81</b>
		2	<b>715-1022</b>	<b>11.54</b>	<b>9.81</b>
		4	<b>715-1024</b>	<b>11.54</b>	<b>9.81</b>
7¾	20	6	<b>715-1026</b>	<b>11.54</b>	<b>9.81</b>
		0	<b>720-1020</b>	<b>15.12</b>	<b>12.85</b>
		2	<b>720-1022</b>	<b>15.12</b>	<b>12.85</b>
		4	<b>720-1024</b>	<b>15.12</b>	<b>12.85</b>
		6	<b>720-1026</b>	<b>15.12</b>	<b>12.85</b>



#### Crochet

Tapered in width and gradually tapered in thickness. Used for filing junctions between flat and curved surfaces and for developing slots with rounded edges.

Length		Cut	Item#	EACH Prices	
inches	cm			1-11	12+
4	10	0	<b>705-1080</b>	<b>\$10.29</b>	<b>\$8.75</b>
		2	<b>705-1082</b>	<b>10.29</b>	<b>8.75</b>
5½	14	0	<b>710-1080</b>	<b>10.76</b>	<b>9.15</b>
		2	<b>710-1082</b>	<b>10.76</b>	<b>9.15</b>
6¼	16	0	<b>715-1080</b>	<b>11.54</b>	<b>9.81</b>
		2	<b>715-1082</b>	<b>11.54</b>	<b>9.81</b>

**Swiss Needle Files, continued**



**Crossing**

Half-round on two sides with one side having a larger radius than the other. Tapered in width and thickness. Cut and usable to the point. Used primarily for filing interior curved surfaces. The double radius allows filing at the junction of two curved surfaces or of a straight and curved surface.

Length		Cut	Item#	EACH Prices	
inches	cm			1-11	12+
4	10	0	<b>705-1090</b>	<b>\$10.29</b>	<b>\$8.75</b>
		2	<b>705-1092</b>	<b>10.76</b>	<b>9.15</b>
		4	<b>710-1094</b>	<b>10.76</b>	<b>9.15</b>
5½	14	0	<b>710-1090</b>	<b>10.76</b>	<b>9.15</b>
		2	<b>710-1092</b>	<b>10.76</b>	<b>9.15</b>
		4	<b>710-1094</b>	<b>10.76</b>	<b>9.15</b>
6¼	16	0	<b>715-1090</b>	<b>11.54</b>	<b>9.81</b>
		2	<b>715-1092</b>	<b>11.54</b>	<b>9.81</b>
		4	<b>715-1094</b>	<b>11.54</b>	<b>9.81</b>
		6	<b>715-1096</b>	<b>11.54</b>	<b>9.81</b>
7¾	20	0	<b>720-1090</b>	<b>15.12</b>	<b>12.85</b>
		2	<b>720-1092</b>	<b>15.12</b>	<b>12.85</b>
		4	<b>720-1094</b>	<b>15.12</b>	<b>12.85</b>



**Equalling**

Parallel in width and thickness. Used primarily for filing slots and corners.

Length		Cut	Item#	EACH Prices	
inches	cm			1-11	12+
4	10	0	<b>705-1100</b>	<b>\$10.29</b>	<b>\$8.75</b>
		2	<b>705-1102</b>	<b>10.29</b>	<b>8.75</b>
		4	<b>705-1104</b>	<b>10.29</b>	<b>8.75</b>
5½	14	00	<b>710-1101</b>	<b>9.95</b>	<b>8.46</b>
		0	<b>710-1100</b>	<b>10.76</b>	<b>9.15</b>
		2	<b>710-1102</b>	<b>10.76</b>	<b>9.15</b>
6¼	16	4	<b>710-1104</b>	<b>10.76</b>	<b>9.15</b>
		00	<b>715-1109</b>	<b>11.54</b>	<b>9.81</b>
		0	<b>715-1100</b>	<b>11.54</b>	<b>9.81</b>
7¾	20	2	<b>715-1102</b>	<b>11.54</b>	<b>9.81</b>
		4	<b>715-1104</b>	<b>11.54</b>	<b>9.81</b>
		6	<b>715-1106</b>	<b>11.54</b>	<b>9.81</b>
		0	<b>720-1100</b>	<b>15.12</b>	<b>12.85</b>
7¾	20	2	<b>720-1102</b>	<b>15.12</b>	<b>12.85</b>
		4	<b>720-1104</b>	<b>15.12</b>	<b>12.85</b>





### Half-Round

Tapered in width and thickness, coming to a point. Cut on both sides.

Length		Cut	Item#	EACH Prices	
inches	cm			1-11	12+
4	10	0	<b>705-1030</b>	<b>\$10.29</b>	<b>\$8.75</b>
		2	<b>705-1032</b>	<b>10.87</b>	<b>9.24</b>
		4	<b>705-1034</b>	<b>9.35</b>	<b>7.95</b>
5½	14	0	<b>710-1030</b>	<b>10.76</b>	<b>9.15</b>
		2	<b>710-1032</b>	<b>10.76</b>	<b>9.15</b>
		4	<b>710-1034</b>	<b>10.76</b>	<b>9.15</b>
6¼	16	00	<b>715-1039</b>	<b>11.54</b>	<b>9.81</b>
		0	<b>715-1030</b>	<b>11.54</b>	<b>9.81</b>
		2	<b>715-1032</b>	<b>11.54</b>	<b>9.81</b>
		4	<b>715-1034</b>	<b>11.54</b>	<b>9.81</b>
7¾	20	0	<b>720-1030</b>	<b>15.12</b>	<b>12.85</b>
		2	<b>720-1032</b>	<b>15.12</b>	<b>12.85</b>
		4	<b>720-1034</b>	<b>15.12</b>	<b>12.85</b>



### Knife-Edge

Tapered in width and thickness, but the knife edge has the same thickness from point to shoulder. The included angle of the sharp edge is approximately 10°. Generally used to file in a slot or wedge-shaped opening. Curved knife edge allows easy filing in restricted areas.

Length		Cut	Item#	EACH Prices	
inches	cm			1-11	12+
4	10	0	<b>705-1110</b>	<b>\$10.29</b>	<b>\$8.75</b>
		2	<b>705-1112</b>	<b>10.29</b>	<b>8.75</b>
5½	14	0	<b>710-1110</b>	<b>10.76</b>	<b>9.15</b>
		2	<b>710-1112</b>	<b>10.76</b>	<b>9.15</b>
		4	<b>710-1114</b>	<b>10.76</b>	<b>9.15</b>
6¼	16	0	<b>715-1110</b>	<b>11.54</b>	<b>9.81</b>
		2	<b>715-1112</b>	<b>11.54</b>	<b>9.81</b>
		4	<b>715-1114</b>	<b>11.54</b>	<b>9.81</b>
		6	<b>715-1116</b>	<b>11.54</b>	<b>9.81</b>
7¾	20	0	<b>720-1110</b>	<b>15.12</b>	<b>12.85</b>
		2	<b>720-1112</b>	<b>15.12</b>	<b>12.85</b>
		4	<b>720-1114</b>	<b>15.12</b>	<b>12.85</b>



### Marking

Identical to half-round, but cut on round side only. Flat side is safe.

Length		Cut	Item#	EACH Prices	
inches	cm			1-11	12+
6¼	16	0	<b>715-1120</b>	<b>\$11.54</b>	<b>\$9.81</b>
		2	<b>715-1122</b>	<b>11.54</b>	<b>9.81</b>
		4	<b>715-1124</b>	<b>11.54</b>	<b>9.81</b>

**Swiss Escapement Files, continued**



**Oval**

Oval shape, gradually tapered to tip. Cut and workable to the point. Used for filing interior curved surfaces.

Length		Cut	Item#	EACH Prices	
inches	cm			1-11	12+
6¼	16	0	<b>715-1140</b>	<b>\$11.54</b>	<b>\$9.81</b>
		2	<b>715-1142</b>	<b>11.54</b>	<b>9.81</b>
		4	<b>715-1144</b>	<b>11.54</b>	<b>9.81</b>



**Round**

Gradually tapered. Cut and workable to the point. Used where it is necessary to enlarge a hole or round off a radius.

Length		Cut	Item#	EACH Prices	
inches	cm			1-11	12+
4	10	0	<b>705-1050</b>	<b>\$10.29</b>	<b>\$8.75</b>
		2	<b>705-1052</b>	<b>10.29</b>	<b>8.75</b>
		4	<b>705-1054</b>	<b>10.29</b>	<b>8.75</b>
5½	14	0	<b>710-1050</b>	<b>10.76</b>	<b>9.15</b>
		2	<b>710-1052</b>	<b>10.76</b>	<b>9.15</b>
		4	<b>710-1054</b>	<b>10.76</b>	<b>9.15</b>
6¼	16	00	<b>715-1059</b>	<b>11.54</b>	<b>9.81</b>
		0	<b>715-1050</b>	<b>11.54</b>	<b>9.81</b>
		2	<b>715-1052</b>	<b>11.54</b>	<b>9.81</b>
		4	<b>715-1054</b>	<b>11.54</b>	<b>9.81</b>
		6	<b>715-1056</b>	<b>11.54</b>	<b>9.81</b>
7¾	20	0	<b>720-1050</b>	<b>15.12</b>	<b>12.85</b>
		2	<b>720-1052</b>	<b>15.12</b>	<b>12.85</b>
		4	<b>720-1054</b>	<b>15.12</b>	<b>12.85</b>



**Square**

Gradually tapered and cut on all four sides. Cut and usable to the point. A general-purpose file.

Length		Cut	Item#	EACH Prices	
inches	cm			1-11	12+
4	10	0	<b>705-1060</b>	<b>\$10.29</b>	<b>\$8.75</b>
		2	<b>705-1062</b>	<b>10.29</b>	<b>8.75</b>
		4	<b>705-1064</b>	<b>10.45</b>	<b>8.88</b>
5½	14	0	<b>710-1060</b>	<b>10.76</b>	<b>9.15</b>
		2	<b>710-1062</b>	<b>10.76</b>	<b>9.15</b>
		4	<b>710-1064</b>	<b>10.76</b>	<b>9.15</b>
6¼	16	00	<b>715-2069</b>	<b>11.54</b>	<b>9.81</b>
		0	<b>715-2060</b>	<b>11.54</b>	<b>9.81</b>
		2	<b>715-2062</b>	<b>11.54</b>	<b>9.81</b>
		4	<b>715-2064</b>	<b>11.54</b>	<b>9.81</b>
		6	<b>715-2066</b>	<b>11.54</b>	<b>9.81</b>
7¾	20	0	<b>720-1060</b>	<b>15.12</b>	<b>12.85</b>
		2	<b>720-1062</b>	<b>15.12</b>	<b>12.85</b>
		4	<b>720-1064</b>	<b>15.12</b>	<b>12.85</b>



### Three-Square

Gradually tapered and cut to the point.

Length		Cut	Item#	EACH Prices	
inches	cm			1-11	12+
4	10	0	<b>705-1010</b>	<b>\$10.76</b>	<b>\$9.15</b>
		2	<b>705-1012</b>	<b>10.76</b>	<b>9.15</b>
		4	<b>705-1014</b>	<b>10.45</b>	<b>8.88</b>
5½	14	0	<b>710-1010</b>	<b>10.76</b>	<b>9.15</b>
		2	<b>710-1012</b>	<b>10.76</b>	<b>9.15</b>
		4	<b>710-1014</b>	<b>10.76</b>	<b>9.15</b>
6¼	16	00	<b>715-1069</b>	<b>11.54</b>	<b>9.81</b>
		0	<b>715-1060</b>	<b>11.54</b>	<b>9.81</b>
		2	<b>715-1062</b>	<b>11.54</b>	<b>9.81</b>
		4	<b>715-1064</b>	<b>11.54</b>	<b>9.81</b>
		6	<b>715-1066</b>	<b>11.54</b>	<b>9.81</b>
7¾	20	0	<b>720-1010</b>	<b>15.12</b>	<b>12.85</b>
		2	<b>720-1012</b>	<b>15.12</b>	<b>12.85</b>
		4	<b>720-1014</b>	<b>15.12</b>	<b>12.85</b>
		6	<b>720-1016</b>	<b>15.12</b>	<b>12.85</b>

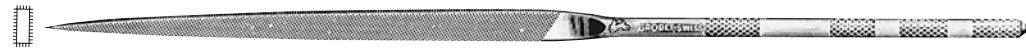

### Warding

Parallel in thickness and tapered in width. Good for deburring.

Length		Cut	Item#	EACH Prices	
inches	cm			1-11	12+
5½	14	0	<b>710-1070</b>	<b>\$10.76</b>	<b>\$9.15</b>
		2	<b>710-1072</b>	<b>10.76</b>	<b>9.15</b>
		4	<b>710-1074</b>	<b>10.76</b>	<b>9.15</b>
6¼	16	0	<b>715-1070</b>	<b>11.54</b>	<b>9.81</b>
		2	<b>715-1072</b>	<b>11.54</b>	<b>9.81</b>
		4	<b>715-1074</b>	<b>11.54</b>	<b>9.81</b>
		6	<b>715-1076</b>	<b>11.54</b>	<b>9.81</b>
7¾	20	0	<b>720-1070</b>	<b>15.12</b>	<b>12.85</b>
		2	<b>720-1072</b>	<b>15.12</b>	<b>12.85</b>
		4	<b>720-1074</b>	<b>15.12</b>	<b>12.85</b>

### **A** Assorted Swiss Needle File Sets

Each includes 12 files of one cut in our most popular shapes. Packaged in plastic pouch with snap closure.

Length		Cuts	Item#	Set of 12
inches	cm			
4	10	0	<b>703-1000</b>	<b>\$96.72</b>
		2	<b>703-1020</b>	<b>96.72</b>
5½	14	0	<b>703-1400</b>	<b>105.51</b>
		2	<b>703-1420</b>	<b>105.51</b>
		4	<b>703-1440</b>	<b>105.51</b>
6¼	16	0	<b>703-1600</b>	<b>112.84</b>
		2	<b>703-1620</b>	<b>112.84</b>
		4	<b>703-1640</b>	<b>112.84</b>
		6	<b>703-1660</b>	<b>112.84</b>
7¾	20	0	<b>703-2000</b>	<b>120.38</b>
		2	<b>703-2020</b>	<b>120.38</b>

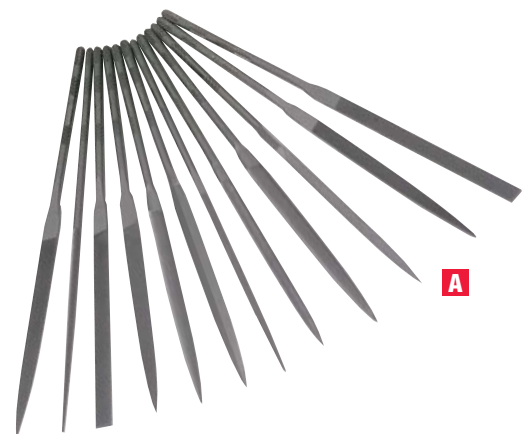

**A**

**Swiss Escapement Files**

Sometimes known as square-handled needle files, escapement files are used for filing even smaller items such as fine extrusion dies and making fine repairs. Measure 14cm (5½") long with 1½" to 2½" cut length.



**Barrette**

Tapered in width and thickness, coming to a point. Only flat side is cut, providing safe edge and top.

Length		Cut	Item#	EACH Prices	
inches	cm			1-11	12+
5½	14	0	<b>725-1100</b>	<b>\$17.38</b>	<b>\$14.77</b>
		2	<b>725-1102</b>	<b>17.38</b>	<b>14.77</b>
		4	<b>725-1104</b>	<b>17.38</b>	<b>14.77</b>
		6	<b>725-1106</b>	<b>17.38</b>	<b>14.77</b>
		8	<b>725-1108</b>	<b>20.42</b>	<b>17.36</b>



**Barrette, Parallel**

Same as Barrette (above) but with parallel sides.

Length		Cut	Item#	EACH Prices	
inches	cm			1-11	12+
5½	14	2	<b>725-1112</b>	<b>\$17.38</b>	<b>\$14.77</b>
		4	<b>725-1114</b>	<b>17.38</b>	<b>14.77</b>
		6	<b>725-1116</b>	<b>17.38</b>	<b>14.77</b>



**Crossing**

Half-round on two sides with one side having a larger radius than the other. Tapered in width and thickness. Cut and usable to the point. Used primarily for filing interior curved surfaces. The double radius allows filing at the junction of two curved surfaces or of a straight and curved surface.

Length		Cut	Item#	EACH Prices	
inches	cm			1-11	12+
5½	14	2	<b>725-1032</b>	<b>\$17.38</b>	<b>\$14.77</b>
		4	<b>725-1034</b>	<b>17.38</b>	<b>14.77</b>
		6	<b>725-1036</b>	<b>17.38</b>	<b>14.77</b>



**Equalling**

Parallel in width and thickness. Used primarily for filing slots and corners.

Length		Cut	Item#	EACH Prices	
inches	cm			1-11	12+
5½	14	2	<b>725-1082</b>	<b>\$17.38</b>	<b>\$14.77</b>
		4	<b>725-1084</b>	<b>17.38</b>	<b>14.77</b>
		6	<b>725-1086</b>	<b>21.68</b>	<b>18.43</b>



### Half-Round

Tapered in width and thickness, coming to a point. Cut on both sides.

Length		Cut	Item#	EACH Prices	
inches	cm			1-11	12+
5½	14	0	<b>725-1020</b>	<b>\$17.38</b>	<b>\$14.77</b>
		2	<b>725-1022</b>	<b>17.38</b>	<b>14.77</b>
		4	<b>725-1024</b>	<b>17.38</b>	<b>14.77</b>
		6	<b>725-1026</b>	<b>20.42</b>	<b>17.36</b>
		8	<b>725-1028</b>	<b>20.42</b>	<b>17.36</b>



### Knife-Edge

Tapered in width and thickness, but the knife edge has the same thickness from point to shoulder. The included angle of the sharp edge is approximately 10°. Generally used to file in a slot or wedge-shaped opening. Curved knife edge allows easy filing in restricted areas.

Length		Cut	Item#	EACH Prices	
inches	cm			1-11	12+
5½	14	2	<b>725-1092</b>	<b>\$17.38</b>	<b>\$14.77</b>
		4	<b>725-1094</b>	<b>17.38</b>	<b>14.77</b>
		6	<b>725-1096</b>	<b>17.38</b>	<b>14.77</b>



### Round

Gradually tapered. Cut and workable to the point. Used where it is necessary to enlarge a hole or round off a radius.

Length		Cut	Item#	EACH Prices	
inches	cm			1-11	12+
5½	14	0	<b>725-1010</b>	<b>\$17.38</b>	<b>\$14.77</b>
		2	<b>725-1012</b>	<b>17.38</b>	<b>14.77</b>
		4	<b>725-1014</b>	<b>17.38</b>	<b>14.77</b>
		6	<b>725-1016</b>	<b>17.38</b>	<b>14.77</b>
		8	<b>725-1018</b>	<b>20.42</b>	<b>17.36</b>



### Rounding Off

Cut on flat side only.

Length		Cut	Item#	EACH Prices	
inches	cm			1-11	12+
5½	14	4	<b>725-1124</b>	<b>\$17.38</b>	<b>\$14.77</b>
		6	<b>725-1126</b>	<b>17.38</b>	<b>14.77</b>



**Swiss Escapement Files, continued**



**Square**

Gradually tapered and cut on all four sides. Cut and usable to the point. A general-purpose file.

Length		Cut	Item#	EACH Prices	
inches	cm			1-11	12+
5½	14	0	<b>725-1040</b>	<b>\$17.38</b>	<b>\$14.77</b>
		2	<b>725-1042</b>	<b>17.38</b>	<b>14.77</b>
		4	<b>725-1044</b>	<b>17.38</b>	<b>14.77</b>
		6	<b>725-1046</b>	<b>17.38</b>	<b>14.77</b>
		8	<b>725-1048</b>	<b>17.38</b>	<b>14.77</b>



**Three-Square**

Gradually tapered and cut to the point.

Length		Cut	Item#	EACH Prices	
inches	cm			1-11	12+
5½	14	0	<b>725-1050</b>	<b>\$17.38</b>	<b>\$14.77</b>
		2	<b>725-1052</b>	<b>17.38</b>	<b>14.77</b>
		4	<b>725-1054</b>	<b>17.38</b>	<b>14.77</b>
		6	<b>725-1056</b>	<b>17.38</b>	<b>14.77</b>
		8	<b>725-1058</b>	<b>20.42</b>	<b>17.36</b>



**Three-Square, Short and Slim**

Cut on all three sides, tapered to a point.

Length		Cut	Item#	EACH Prices	
inches	cm			1-11	12+
5½	14	2	<b>725-1062</b>	<b>\$17.38</b>	<b>\$14.77</b>
		4	<b>725-1064</b>	<b>17.38</b>	<b>14.77</b>
		6	<b>725-1066</b>	<b>17.38</b>	<b>14.77</b>

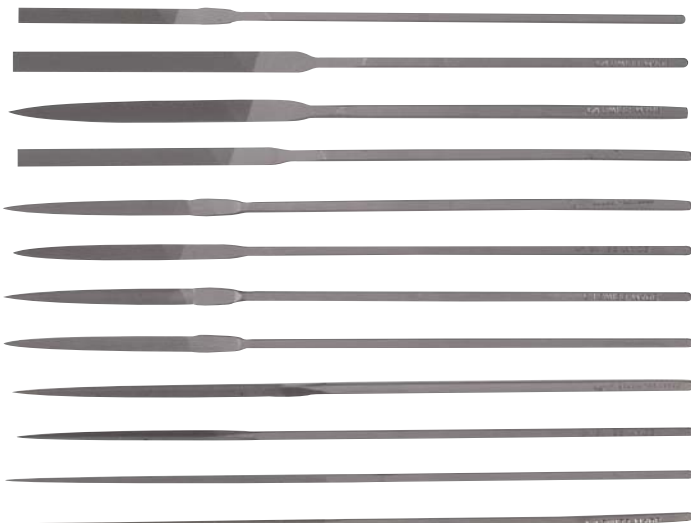

**A Swiss Escapement File Set**

Includes 12 popular shapes, all cut 2.





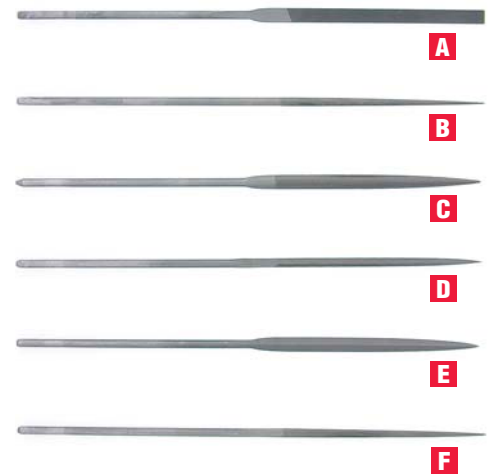

Description	Item#	Set of 12
Swiss Escapement File Set	<b>725-2002</b>	<b>\$199.50</b>

**A**

**A - F Flexi-Files – Files that actually bend!**

These 66 HRC electric steel alloy files can be bent to conform to any shape desired while still maintaining their hardness. Feature tooth design that permits free flow of chips for precise and efficient cutting with maximum stability and minimum heat buildup. Can be used with or without a file handle. Measure 6¼" long. All cut 2.



Description	Shape	Item#	EACH Prices	
			1-11	12+
A. Equalling		<b>702-0001</b>	<b>\$17.50</b>	<b>\$14.58</b>
B. Round		<b>702-0003</b>	<b>17.50</b>	<b>14.58</b>
C. Half-Round		<b>702-0005</b>	<b>17.50</b>	<b>14.58</b>
D. Three-Square		<b>702-0009</b>	<b>17.50</b>	<b>14.58</b>
E. Barrette		<b>702-0011</b>	<b>17.50</b>	<b>14.58</b>
F. Square		<b>702-0007</b>	<b>17.50</b>	<b>14.58</b>
6-Piece Set (one of each)		<b>702-0013</b>	<b>75.00</b>	<b>-</b>

**G Needle File Stand – Keeps files organized and easily accessible.**

This attractive metal stand conveniently holds and displays up to 12 needle files in 4", 5½" or 6¼" lengths. Freestanding on workbench, hanging on peg or snapped closed for carrying, it keeps your frequently used files visible and handy at all times. (Files not included.)

Description	Item#	Each
Needle File Stand	<b>704-3070</b>	<b>\$12.15</b>

**H Wood File Handles**

Hardwood handles with metal ferrules. Hold needle files, escapement files and gravers. Measure 4" long. Available in two diameters.

Description	Dia.	Item#	EACH Prices	
			1-11	12+
Wood File Handle	3/8"	<b>170-6010</b>	<b>\$1.15</b>	<b>\$1.04</b>
	5/8"	<b>170-6011</b>	<b>1.15</b>	<b>1.04</b>

**I File and Burnisher Handle**

Hardwood handle with metal ferrules. Slightly curved to fit comfortably in your hand. Measures 3 7/8" long.

Description	Item#	Each
File and Burnisher Handle	<b>170-3005</b>	<b>\$2.20</b>

**J Needle File Handle**

Durable plastic handle for holding all needle files and most single-ended rifflers. Measures 3 1/4" long.

Description	Item#	EACH Prices	
		1-11	12+
Needle File Handle	<b>170-4010</b>	<b>\$4.45</b>	<b>\$3.78</b>

**K File Card**

Feature steel wire bristles mounted on a wood handle for cleaning particles caught in teeth of files. Measures 8" long.

Description	Item#	EACH Prices	
		1-5	6+
File Card	<b>816-2800</b>	<b>\$5.90</b>	<b>\$4.72</b>



## Swiss Diesinker's Rifflers

All are double-ended files. Illustrations feature one side (both sides are identical except for 905, which is straight and curved). All measure 6" long. Available individually or in sets of 12, 18 or 24.

*All double-ended.*



*Both ends shown of style 905.*



Style	Cut 0 Item#	Cut 2 Item#	Cut 4 Item#	EACH Prices	
				1-11	12+*
900	<b>700-9000</b>	<b>700-9002</b>	<b>700-9004</b>	<b>\$28.89</b>	<b>\$24.56</b>
901	<b>700-9010</b>	<b>700-9012</b>	—	<b>28.89</b>	<b>24.56</b>
902	<b>700-9020</b>	<b>700-9022</b>	—	<b>28.89</b>	<b>24.56</b>
905	<b>700-9050</b>	<b>700-9052</b>	<b>700-9054</b>	<b>28.89</b>	<b>24.56</b>
911	<b>700-9110</b>	<b>700-9112</b>	<b>700-9114</b>	<b>28.89</b>	<b>24.56</b>
912	<b>700-9120</b>	<b>700-9122</b>	<b>700-9124</b>	<b>28.89</b>	<b>24.56</b>
913	<b>700-9130</b>	<b>700-9132</b>	<b>700-9134</b>	<b>28.89</b>	<b>24.56</b>
914	<b>700-9140</b>	<b>700-9142</b>	<b>700-9144</b>	<b>28.89</b>	<b>24.56</b>
915	<b>700-9150</b>	<b>700-9152</b>	<b>700-9154</b>	<b>28.89</b>	<b>24.56</b>
917	<b>700-9170</b>	<b>700-9172</b>	—	<b>28.89</b>	<b>24.56</b>
918	<b>700-9180</b>	<b>700-9182</b>	—	<b>28.89</b>	<b>24.56</b>
919	<b>700-9190</b>	<b>700-9192</b>	—	<b>28.89</b>	<b>24.56</b>
920	<b>700-9200</b>	<b>700-9202</b>	<b>700-9204</b>	<b>28.89</b>	<b>24.56</b>
930	<b>700-9300</b>	<b>700-9302</b>	—	<b>28.89</b>	<b>24.56</b>
931	—	<b>700-9312</b>	<b>700-9314</b>	<b>28.89</b>	<b>24.56</b>
940	<b>700-9400</b>	<b>700-9402</b>	<b>700-9404</b>	<b>28.89</b>	<b>24.56</b>
941	<b>700-9410</b>	<b>700-9412</b>	<b>700-9414</b>	<b>28.89</b>	<b>24.56</b>
942	<b>700-9420</b>	<b>700-9422</b>	<b>700-9424</b>	<b>28.89</b>	<b>24.56</b>
950	<b>700-9500</b>	<b>700-9502</b>	—	<b>28.89</b>	<b>24.56</b>

\*Qty. discounts for orders of one item# only, not assorted.

Style	Cut 0 Item#	Cut 2 Item#	Cut 4 Item#	EACH Prices	
				1-11	12+*
951	<b>700-9510</b>	<b>700-9512</b>	–	<b>\$28.89</b>	<b>\$24.56</b>
952	<b>700-9520</b>	<b>700-9522</b>	–	<b>28.89</b>	<b>24.56</b>
953	<b>700-9530</b>	<b>700-9532</b>	–	<b>28.89</b>	<b>24.56</b>
954	<b>700-9540</b>	<b>700-9542</b>	–	<b>28.89</b>	<b>24.56</b>
955	<b>700-9550</b>	<b>700-9552</b>	–	<b>25.80</b>	<b>21.93</b>
956	<b>700-9560</b>	<b>700-9562</b>	<b>700-9564</b>	<b>25.80</b>	<b>21.93</b>
957	–	<b>700-9572</b>	–	<b>25.80</b>	<b>21.93</b>
958	<b>700-9580</b>	<b>700-9582</b>	<b>700-9584</b>	<b>28.89</b>	<b>24.56</b>
961	<b>700-9610</b>	<b>700-9612</b>	–	<b>28.89</b>	<b>24.56</b>
962	<b>700-9620</b>	<b>700-9622</b>	<b>700-9624</b>	<b>28.89</b>	<b>24.56</b>
963	<b>700-9630</b>	<b>700-9632</b>	<b>700-9634</b>	<b>25.80</b>	<b>21.93</b>
964	<b>700-9640</b>	<b>700-9642</b>	<b>700-9644</b>	<b>25.80</b>	<b>21.93</b>
965	<b>700-9650</b>	<b>700-9652</b>	<b>700-9654</b>	<b>25.80</b>	<b>21.93</b>
970	<b>700-9700</b>	<b>700-9702</b>	<b>700-9704</b>	<b>28.89</b>	<b>24.56</b>
971	<b>700-9710</b>	<b>700-9712</b>	<b>700-9714</b>	<b>28.89</b>	<b>24.56</b>
972	<b>700-9720</b>	<b>700-9722</b>	–	<b>25.80</b>	<b>21.93</b>
973	<b>700-9730</b>	<b>700-9732</b>	<b>700-9734</b>	<b>25.80</b>	<b>21.93</b>
975	<b>700-9750</b>	<b>700-9752</b>	<b>700-9754</b>	<b>25.80</b>	<b>21.93</b>
981	<b>700-9810</b>	<b>700-9812</b>	<b>700-9814</b>	<b>25.80</b>	<b>21.93</b>
982	<b>700-9820</b>	<b>700-9822</b>	<b>700-9824</b>	<b>25.80</b>	<b>21.93</b>

*All double-ended.*

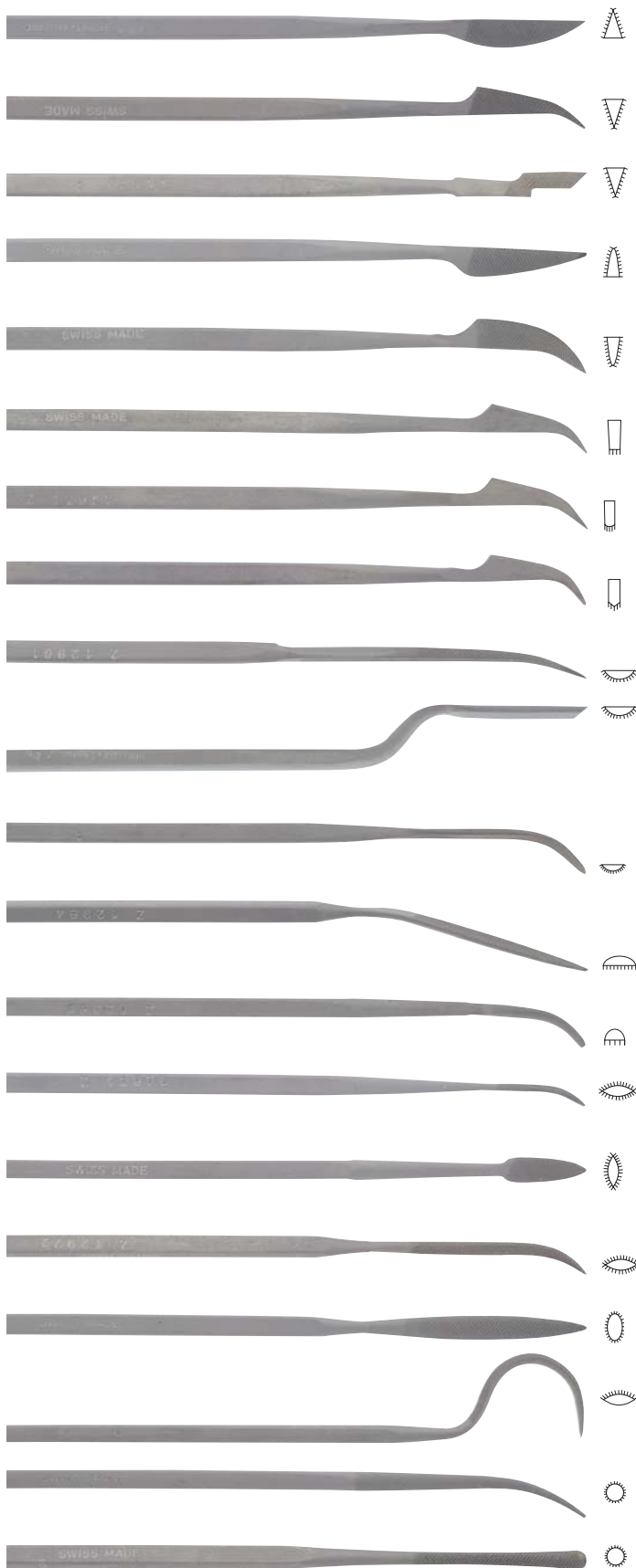

\*Qty. discounts for orders of one item# only, not assorted.

## Swiss Diesinker's Rifflers, continued

*All double-ended.*

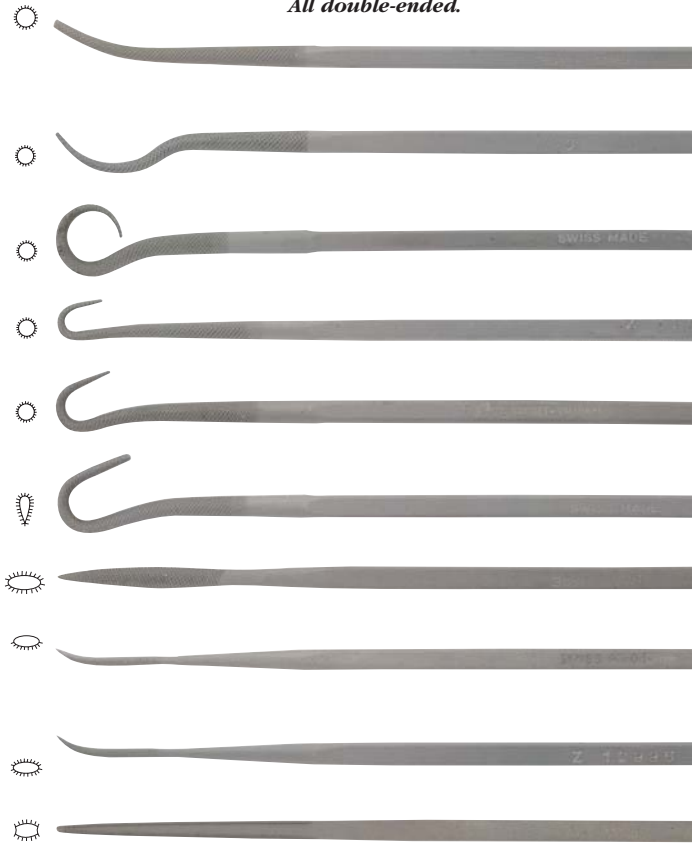

Style	Cut 0 Item#	Cut 2 Item#	Cut 4 Item#	EACH Prices	
				1-11	12+*
983	<b>700-9830</b>	<b>700-9832</b>	<b>700-9834</b>	<b>\$28.79</b>	<b>\$24.47</b>
984	<b>700-9840</b>	<b>700-9842</b>	<b>700-9844</b>	<b>28.79</b>	<b>24.47</b>
985	<b>700-9850</b>	<b>700-9852</b>	<b>700-9854</b>	<b>28.79</b>	<b>24.47</b>
986	<b>700-9860</b>	<b>700-9862</b>	<b>700-9864</b>	<b>28.79</b>	<b>24.47</b>
987	<b>700-9870</b>	<b>700-9872</b>	<b>700-9874</b>	<b>28.79</b>	<b>24.47</b>
988	<b>700-9880</b>	<b>700-9882</b>	<b>700-9884</b>	<b>28.79</b>	<b>24.47</b>
990	<b>700-9900</b>	<b>700-9902</b>	<b>700-9904</b>	<b>28.79</b>	<b>24.47</b>
995	<b>700-9950</b>	<b>700-9952</b>	<b>700-9954</b>	<b>28.79</b>	<b>24.47</b>
996	-	<b>700-9962</b>	<b>700-9964</b>	<b>28.79</b>	<b>24.47</b>
997	<b>700-9970</b>	<b>700-9972</b>	<b>700-9974</b>	<b>28.79</b>	<b>24.47</b>

\*Qty. discounts for orders of one item# only, not assorted.

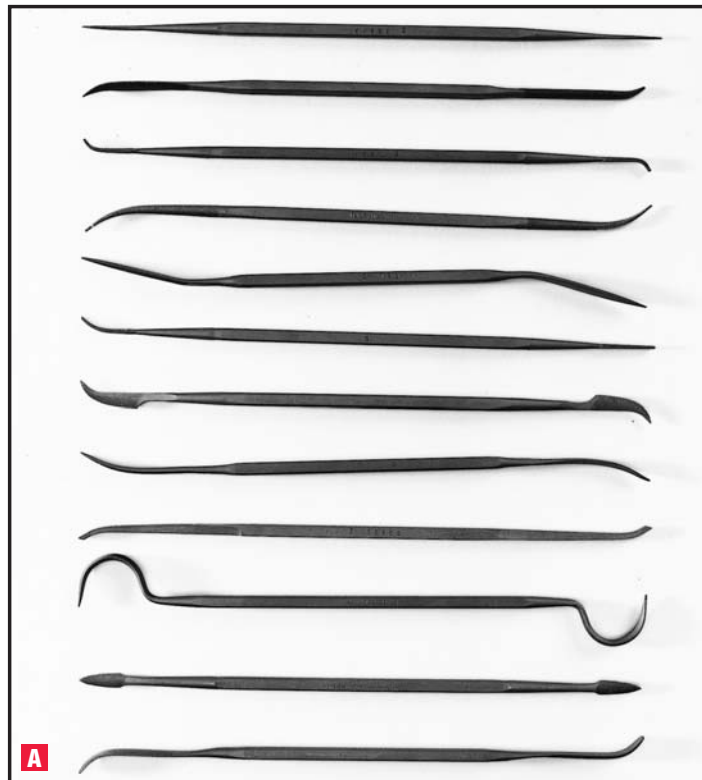

## Swiss Diesinker's Riffler Sets

### **A** Set of 12

Styles: 900, 901, 905, 911, 919, 955, 963, 964, 971, 975, 981, 994.

Cut 0 Item#	Cut 2 Item#	Cut 4 Item#	Set of 12
<b>703-0100</b>	<b>703-0120</b>	<b>703-0140</b>	<b>\$289.00</b>

### Set of 18

Styles: 900, 941, 955, 956, 957, 958, 963, 964, 965, 971, 972, 973, 974, 975, 981, 982, 983, 994.

Cut 0 Item#	Cut 2 Item#	Cut 4 Item#	Set of 18
<b>703-0200</b>	<b>703-0220</b>	<b>703-0240</b>	<b>\$434.00</b>

### Set of 24

Styles: 900, 901, 905, 911, 913, 919, 941, 955, 956, 957, 958, 963, 964, 965, 971, 972, 973, 974, 975, 981, 982, 983, 988, 994.

Description	Item#	Set of 24
Cut 2	<b>703-0320</b>	<b>\$579.00</b>
Cut 4	<b>703-0340</b>	<b>504.75</b>



**Diemaker's Rifflers**

For removing metal and smoothing hard-to-reach surfaces. All are double-ended, both ends identical. Measure approx. 7" overall length. Available individually, per dozen (all one style and cut) or in sets of 12.

Style	Cut 0 Item#	Cut 2 Item#	EACH Prices	
			1-11	12+*
711	<b>700-7110</b>	<b>700-7112</b>	<b>\$35.23</b>	<b>\$29.95</b>
712	<b>700-7120</b>	<b>700-7122</b>	<b>35.23</b>	<b>29.95</b>
713	<b>700-7130</b>	<b>700-7132</b>	<b>35.23</b>	<b>29.95</b>
731	<b>700-7310</b>	<b>700-7312</b>	<b>35.23</b>	<b>29.95</b>
732	<b>700-7320</b>	<b>700-7322</b>	<b>35.23</b>	<b>29.95</b>
741	<b>700-7410</b>	<b>700-7412</b>	<b>42.80</b>	<b>36.38</b>
750	<b>700-7500</b>	<b>700-7502</b>	<b>42.80</b>	<b>36.38</b>
761	<b>700-7610</b>	<b>700-7612</b>	<b>42.80</b>	<b>36.38</b>
762	<b>700-7620</b>	<b>700-7622</b>	<b>42.80</b>	<b>36.38</b>
763	<b>700-7630</b>	<b>700-7632</b>	<b>42.80</b>	<b>36.38</b>
764	-	<b>700-7642</b>	<b>39.86</b>	<b>33.88</b>
771	<b>700-7710</b>	<b>700-7712</b>	<b>39.86</b>	<b>33.88</b>
781	<b>700-7810</b>	<b>700-7812</b>	<b>39.86</b>	<b>33.88</b>
790	<b>700-7900</b>	<b>700-7902</b>	<b>39.40</b>	<b>33.49</b>
796	<b>700-7960</b>	<b>700-7962</b>	<b>39.40</b>	<b>33.49</b>

\*Qty. discounts for orders of one item# only, not assorted.

*All double-ended.*



**Diemaker's Riffler Sets**

Styles: 711, 713, 731, 732, 741, 750, 761, 763, 764, 771, 781, 790.

Cut 0 Item#	Cut 2 Item#	Set of 12
<b>703-0500</b>	<b>703-0520</b>	<b>\$393.85</b>



**A**



**B**



**C**

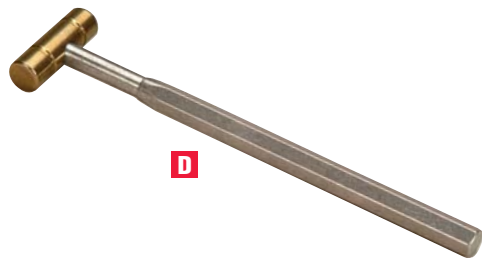

**D**



**E**

## A Chasing Hammers

Each has large hardened face for striking chisels and chasing tools. The opposite end has a ball peen used for forming rivet heads and other work. Well-balanced hardwood handle is oval-gripped for comfort. The narrow shaft provides resilience and spring when striking, reducing the jarring sensation in your hand. Made in Germany.

Face Dia.	Head Wt.	Overall Length	Item#	Each
3/4"	3.5 oz.	10"	<b>821-8243</b>	<b>\$38.50</b>
1"	4 oz.	10"	<b>821-8245</b>	<b>39.50</b>
1 1/8"	5 oz.	10"	<b>821-8250</b>	<b>41.25</b>
1 1/4"	6 oz.	10"	<b>821-8255</b>	<b>42.50</b>

## B Economy Ball-Peen Hammers

Each has hardened steel face for solid striking force. One end flat, the other round. Durable wooden handle. Imported.

Head Dia. x L	Head Wt.	Overall Length	Item#	Each
1/2" x 2"	2 oz.	10 1/2"	<b>821-8050</b>	<b>\$4.05</b>
3/4" x 2 3/4"	4 oz.	10 1/2"	<b>821-8100</b>	<b>4.55</b>
7/8" x 3"	8 oz.	10 1/2"	<b>821-8150</b>	<b>5.05</b>

## C Brass Head Mallet

Brass head will not mar steel surfaces. Wooden handle made of seasoned hickory provides extra strength and durability.

Head Dia. x L	Head Wt.	Overall Length	Item#	Each
1 1/16" x 2"	4 oz.	8 1/4"	<b>822-0040</b>	<b>\$9.95</b>

## D Brass Flat/Ball-Peen Hammer

This 2 oz. hammer features a high-quality solid brass head threaded onto an anodized aluminum handle. Head is attached with special compound to ensure that it will not release. Hexagonal shaped handle prevents slipping. Made in USA.

Head Dia. x L	Head Wt.	Overall Length	Item#	Each
1/2" x 1 3/4"	2 oz.	8"	<b>821-8170</b>	<b>\$12.95</b>

## E K & D® Brass/Nylon Mallets – With detachable faces

Each mallet supplied with one brass and one nylon face. Easily replaceable when worn. To change face, simply remove the threaded collar with wrench supplied, slip out worn face and insert new one. Well-made hardwood handle.

Head Dia. x L	Head Wt.	Overall Length	Item#	Each
9/16" x 2 3/4"	3 1/2 oz.	9"	<b>822-0010</b>	<b>\$12.30</b>
5/8" x 2 3/4"	5 oz.	9"	<b>822-0015</b>	<b>15.95</b>
Replacement Faces				
Type	Size		Item#	Each
Brass	Small		822-0020*	\$1.35
Nylon	Small		822-0025*	1.35
Brass	Large		822-0030*	1.35
Nylon	Large		822-0035*	1.35

\*Three-piece minimum; please order in multiples of three.

**A Dead Blow Mallets – With detachable faces**

Excellent for hammering where a heavy blow is required. The non-marring features of the urethane faces make these mallets ideal for separating die sets, seating work in a fixture or vise, straightening castings, forming sheet metal and assembling or disassembling machinery. Each cast-iron head is filled with iron shot. As the mallet is struck, the shot moves forward immediately behind the blow, dampening the rebound and ensuring that the force of the blow is transmitted solidly. Handles are grooved hickory. Each mallet includes two replaceable nonmarring polyurethane faces: one medium (green), one hard (black). Impervious to oils and most solvents.

Head Dia. x L	Head Wt.	Overall Length	Item#	Each
1" x 4 1/4"	3/4 lbs.	11"	<b>821-9070</b>	<b>\$31.95</b>
1 1/2" x 5 1/4"	2 lbs.	13 1/8"	<b>821-9080</b>	<b>42.95</b>
2" x 6 1/4"	3 1/2 lbs.	14 1/2"	<b>821-9090</b>	<b>58.60</b>

Replacement Faces				
Head Dia.	Color	Hardness	Item#	Each
1"	Green	Medium	821-9100	\$6.50
	Black	Hard	821-9110	8.65
1 1/2"	Green	Medium	821-9120	8.95
	Black	Hard	821-9130	11.95
2"	Green	Medium	821-9140	12.15
	Black	Hard	821-9150	17.60



**A**

**B Nylon Mallets – With detachable faces**

Nylon-faced mallets are nonmarking and shock-cushioned. Faces easily screw out for replacement. Handles are plastic with comfortable, nonslip rubber grips impervious to moisture and oil (#821-7080 has a wooden handle).

Head Dia. x L	Head Wt.	Overall Length	Item#	Each
1" x 3 7/8"	10 oz.	10"	<b>821-7080</b>	<b>\$24.50</b>
1 1/4" x 3 7/8"	1 lb.	11 1/2"	<b>821-7100</b>	<b>29.90</b>
1 1/2" x 4 3/4"	1 1/2 lbs.	12"	<b>821-7120</b>	<b>34.20</b>

Replacement Faces			
Head Dia.		Item#	Each
1"		821-7008	\$7.75
1 1/4"		821-7010	9.35
1 1/2"		821-7012	12.40



**B**

**C Rawhide Mallets**

Used when care must be taken not to mar surface being struck. The mallet heads are constructed from tough rawhide with genuine hickory handles. Cylindrical hide coils are hydraulically compressed to ensure uniform size and durability.

Head Dia. x L	Head Wt.	Overall Length	Item#	EACH Prices	
				1-2	3+
1" x 2"	2.5 oz.	8"	<b>821-8800</b>	<b>\$12.50</b>	<b>\$11.25</b>
1 1/4" x 2 1/2"	4.5 oz.	9"	<b>821-8850</b>	<b>14.00</b>	<b>12.60</b>
1 1/2" x 3"	6.0 oz.	10"	<b>821-8900</b>	<b>16.60</b>	<b>14.94</b>
1 3/4" x 3 1/2"	9.5 oz.	11"	<b>821-8950</b>	<b>20.95</b>	<b>18.86</b>
2" x 3 1/2"	12.0 oz.	11 3/4"	<b>821-9000</b>	<b>24.50</b>	<b>22.05</b>
2 3/4" x 4 1/4"	1 1/2 lbs.	13 1/2"	<b>821-9050</b>	<b>44.50</b>	<b>40.05</b>



**C**

## **A SUPRA® Piercing Sawblades – Gesswein’s finest quality at great prices!**

The finest steel, latest technology and true craftsmanship are combined to produce SUPRA Sawblades—the world’s finest! Extremely flexible, they cut straight and stay sharp. Straw-colored. Measure 13cm (5 1/8") in length. Sold by the gross only. Made in Germany.



Size	Thickness	Width	TPI*	Item#	GROSS Prices		
					1-2	3-5	6+
6/0	.0070"	.0140"	82	<b>187-0060</b>	<b>\$26.75</b>	<b>\$24.08</b>	<b>\$21.40</b>
5/0	.0080"	.0157"	80	<b>187-0050</b>	<b>23.70</b>	<b>21.33</b>	<b>18.96</b>
4/0	.0086"	.0175"	72	<b>187-0040</b>	<b>21.35</b>	<b>19.22</b>	<b>17.08</b>
3/0	.0095"	.0190"	66	<b>187-0030</b>	<b>19.35</b>	<b>17.42</b>	<b>15.48</b>
2/0	.0103"	.0204"	62	<b>187-0020</b>	<b>19.35</b>	<b>17.42</b>	<b>15.48</b>
0	.0110"	.0220"	56	<b>187-0010</b>	<b>19.35</b>	<b>17.42</b>	<b>15.48</b>
1	.0120"	.0240"	52	<b>187-0100</b>	<b>19.35</b>	<b>17.42</b>	<b>15.48</b>
2	.0134"	.0276"	48	<b>187-0200</b>	<b>19.35</b>	<b>17.42</b>	<b>15.48</b>
3	.0140"	.0290"	46	<b>187-0300</b>	<b>19.35</b>	<b>17.42</b>	<b>15.48</b>

\*Approx. number of teeth per inch



## **B Herkules® “White Label” Piercing Sawblades**

High-quality sawblades made of hardened and tempered special alloy steel. Teeth are uniform in size, shape and sharpness to ensure fast, easy cutting. For use on hand and power tools with a blade-clamping device. Measure 13cm (5 1/8") in length. Made in Germany.

### Piercing Sawblade Sizes

Size	Thickness	Width	TPI*
8/0	.0063"	.0126"	86
7/0	.0067"	.0130"	84
6/0	.0070"	.0140"	82
5/0	.0080"	.0157"	80
4/0	.0086"	.0175"	72
3/0	.0095"	.0190"	66
2/0	.0103"	.0204"	62
0	.0110"	.0220"	56
1	.0120"	.0240"	52
2	.0134"	.0276"	48
3	.0140"	.0290"	46
4	.0150"	.0307"	40
5	.0158"	.0331"	36
6	.0173"	.0370"	34
7	.0189"	.0400"	32
8	.0197"	.0440"	30
10	.0215"	.0510"	25
12	.0236"	.0650"	21
14	.0236"	.0690"	19

\*Approx. number of teeth per inch

Size	Item#	Dozen	Item#	GROSS Prices		
				1-2	3-5	6+
8/0	<b>185-0080</b>	<b>\$3.30</b>	<b>186-0080</b>	<b>\$27.15</b>	<b>\$24.44</b>	<b>\$21.72</b>
7/0	<b>185-0070</b>	<b>3.30</b>	<b>186-0070</b>	<b>26.25</b>	<b>23.63</b>	<b>21.00</b>
6/0	<b>185-0060</b>	<b>2.95</b>	<b>186-0060</b>	<b>23.60</b>	<b>21.24</b>	<b>18.88</b>
5/0	<b>185-0050</b>	<b>2.80</b>	<b>186-0050</b>	<b>20.95</b>	<b>18.86</b>	<b>16.76</b>
4/0	<b>185-0040</b>	<b>2.60</b>	<b>186-0040</b>	<b>18.85</b>	<b>16.97</b>	<b>15.08</b>
3/0	<b>185-0030</b>	<b>2.50</b>	<b>186-0030</b>	<b>17.00</b>	<b>15.30</b>	<b>13.60</b>
2/0	<b>185-0020</b>	<b>2.50</b>	<b>186-0020</b>	<b>17.00</b>	<b>15.30</b>	<b>13.60</b>
0	<b>185-0010</b>	<b>2.50</b>	<b>186-0010</b>	<b>17.00</b>	<b>15.30</b>	<b>13.60</b>
1	<b>185-0100</b>	<b>2.50</b>	<b>186-0100</b>	<b>17.00</b>	<b>15.30</b>	<b>13.60</b>
2	<b>185-0200</b>	<b>2.50</b>	<b>186-0200</b>	<b>17.00</b>	<b>15.30</b>	<b>13.60</b>
3	<b>185-0300</b>	<b>2.50</b>	<b>186-0300</b>	<b>17.00</b>	<b>15.30</b>	<b>13.60</b>
4	<b>185-0400</b>	<b>2.50</b>	<b>186-0400</b>	<b>17.00</b>	<b>15.30</b>	<b>13.60</b>
5	<b>185-0500</b>	<b>2.80</b>	<b>186-0500</b>	<b>18.85</b>	<b>16.97</b>	<b>15.08</b>
6	<b>185-0600</b>	<b>2.90</b>	<b>186-0600</b>	<b>20.95</b>	<b>18.86</b>	<b>16.76</b>
7	<b>185-0700</b>	<b>3.50</b>	<b>186-0700</b>	<b>28.85</b>	<b>25.97</b>	<b>23.08</b>
8	<b>185-0800</b>	<b>3.50</b>	<b>186-0800</b>	<b>27.95</b>	<b>25.16</b>	<b>22.36</b>
10	<b>185-1000</b>	<b>4.75</b>	<b>186-1000</b>	<b>32.75</b>	<b>29.48</b>	<b>26.20</b>
12	<b>185-1200</b>	<b>4.75</b>	<b>186-1200</b>	<b>40.25</b>	<b>36.23</b>	<b>32.20</b>
14	<b>185-1400</b>	<b>4.75</b>	<b>186-1400</b>	<b>50.50</b>	<b>45.45</b>	<b>40.40</b>



## **C Flat Sawblades**

Designed for heavy-duty cuts. Similar to hacksaw blades.

Size	Thickness	Width	Item#	Dozen
2	.0080"	.0340"	<b>188-1002</b>	<b>\$3.20</b>
6	.0080"	.0590"	<b>188-1006</b>	<b>4.35</b>

**A - D Flat Sawframes**

High-quality, adjustable steel-forged frames in five convenient sizes. Thumbscrews allow quick tightening and loosening of sawblades. Hardened steel plates with serrated surfaces firmly hold sawblades up to 6" in length. Adjustability feature enables use of broken sawblades. Hardwood handles are shaped for comfort. Imported from Germany.

Depth	Item#	Each
<b>A.</b> 2¼"	<b>187-1095</b>	<b>\$11.65</b>
<b>B.</b> 3"	<b>187-1100</b>	<b>12.45</b>
<b>C.</b> 3¾"	<b>187-1150</b>	<b>15.85</b>
<b>D.</b> 4¾"	<b>187-1200</b>	<b>14.95</b>



**E Deluxe Sawframe**

Unique sawframe with machined slots and tenons at both ends to grip sawblades quickly and easily with perfect alignment. Sawblades slip easily into slots and do not fall out or misalign as you tighten the large, sturdy thumbscrews. The special blade-gripping mechanism will not move or wobble during sawing, reducing blade breakage. Black, laser-cut, high-quality spring steel frame allows easy tensioning. Handle is smooth natural wood. Made in Switzerland.

Depth	Item#	Each
70mm (2¾")	<b>187-1097</b>	<b>\$59.00</b>



**F Gesswein® Lube-Stik**

Use on any grinding, cutting, drilling, piercing or similar tool to speed up production and increase tool life. Lube-Stik reduces friction and heat buildup so that tools stay sharper, work faster and cut smoother. Easy to use—just run your tool in the soft lubricant. Supplied in a handy push-up dispenser tube.

Description	Item#	EACH Prices	
		1-9	10+
Lube-Stik	<b>816-2460</b>	<b>\$3.95</b>	<b>\$3.56</b>



**G Diamond Sawblades**

The generous coating of diamond particles electroplated onto piano wire produces long-lasting blades that will make quick work of sawing glass, ceramic and stone. Available in four grits. Measure 5⅜" long with approx. 3" long plated portion.

Description	Grit	Item#	Each
Coarse	60	<b>226-1500</b>	<b>\$8.20</b>
Med. Coarse	100	<b>226-1505</b>	<b>8.20</b>
Medium	120	<b>226-1510</b>	<b>8.20</b>
Med. Fine	140	<b>226-1515</b>	<b>8.20</b>



**H Razor Saw**

A must for cutting metal rod and tubing. The thin, specially hardened, rigid blade has fine teeth, and light pressure can be used to ensure that tubing will not collapse while being cut. Ideal for making square cuts. Use for cutting and trimming light metal, fine wood and plastics. Measures 9⅛" long with 4½"L x 7/16"W blade.

Description	Item#	Each
Razor Saw	<b>812-1281</b>	<b>\$4.95</b>





## Dumont® Hi-Tech Tweezers

Manufactured by the original Swiss Dumont factory. Forged from the best stainless steel and machined to a smooth satin finish. Extensive hand operations are used in shaping, adjusting and finishing the points. Tips are nonserrated unless otherwise indicated.



### A Dumont® 3C Tweezers

For handling all miniature and micro-miniature parts. Points are honed and very sharp. Tapered shanks with bevel edges. Measure approx. 4¼" long.

Style	Item#	EACH Prices		
		1-2	3-9	10+
3C	<b>195-0400</b>	<b>\$18.95</b>	<b>\$17.06</b>	<b>\$16.11</b>



### B Dumont® 5 Tweezers

Ideally suited for handling microscopic parts and delicate work. Very narrow, needle-like points have been extra-honed to extreme sharpness. Indented shanks with bevel edges. Measure approx. 4¼" long.

Style	Item#	EACH Prices		
		1-2	3-9	10+
5	<b>195-0392</b>	<b>\$19.90</b>	<b>\$17.91</b>	<b>\$16.92</b>



### C Dumont® 7 Tweezers

Excellent tweezers for handling all miniature and micro-miniature parts and components. The curved shanks permit the user to rest hand on bench during assembly operations. Points have a plain finish and are very sharp. Measure approx. 4½" long.

Style	Item#	EACH Prices		
		1-2	3-9	10+
7	<b>195-0395</b>	<b>\$21.90</b>	<b>\$19.71</b>	<b>\$18.62</b>



### D, E Dumont® PP and SS Tweezers

Style PP is for sorting, assembling, and handling miniature parts. Has tapered shanks with bevel edges. Points are sharp. Style SS is similar to PP but is very slim. Measure approx. 5¾" long.



Style	Item#	EACH Prices		
		1-2	3-9	10+
D. PP	<b>195-0410</b>	<b>\$18.95</b>	<b>\$17.06</b>	<b>\$16.11</b>
E. SS	<b>195-0405</b>	<b>18.95</b>	<b>17.06</b>	<b>16.11</b>



### F, G Dumont® Boley-Style AA and GG Tweezers

Superbly machined tweezers. Made of stainless steel for very fine sorting, inspection and handling of miniature parts. Excellent for use under low-power magnification. Style AA is for general use. Style GG has pointed indented shanks. Measure approx. 5" long.



Style	Item#	EACH Prices		
		1-2	3-9	10+
F. AA	<b>195-1050</b>	<b>\$18.95</b>	<b>\$17.06</b>	<b>\$16.11</b>
G. GG	<b>195-1150</b>	<b>19.90</b>	<b>17.91</b>	<b>16.92</b>

**A - D Dumont® Serrated Tweezers**

The finest tweezers in the industry. Precision-made with perfect alignment at the tips, which are serrated at a perpendicular angle for the best grip possible. Available with either medium or fine points and with or without a locking mechanism. Made of stainless steel. Measure 6½" long.

Description	Item#	EACH Prices		
		1-2	3-9	10+
<b>A. Fine</b>	<b>195-0350</b>	<b>\$16.55</b>	<b>\$14.90</b>	<b>\$14.07</b>
<b>B. Medium</b>	<b>195-0355</b>	<b>21.20</b>	<b>19.08</b>	<b>18.02</b>
<b>C. Fine, Locking</b>	<b>195-0360</b>	<b>24.20</b>	<b>21.78</b>	<b>20.57</b>
<b>D. Medium, Locking</b>	<b>195-0365</b>	<b>25.30</b>	<b>22.77</b>	<b>21.51</b>



**E Dumont® Grooved Tweezers**

A groove runs down the center of the serrated tips. Have medium points. Made of stainless steel. Measure 5⅞" long.

Description	Item#	EACH Prices		
		1-2	3-9	10+
Grooved Tweezers	<b>195-0356</b>	<b>\$24.60</b>	<b>\$22.14</b>	<b>\$20.91</b>



**F Dumont® Titanium Tweezers**

These 100% nonmagnetic tweezers are manufactured with a high standard of excellence. Titanium is 40% lighter than steel and 60% stronger. These tweezers have a light touch and strong points. Measure 4¾" long.

Description	Tips	Finish	Item#	Each
<b>F. Style 1</b>	Sharp	Honed	<b>195-3280</b>	<b>\$22.15</b>
Style 3	Very Sharp	Fine Honed	<b>195-3281</b>	<b>26.95</b>



**G, H Boley-Style Tweezers**

Excellent tweezers for handling miniature parts. All shanks are tapered and have bevel edges. The sharp finished points have smooth tips. Style RR has hefty, wide shanks for heavy-duty use. Style MM is for general use.

Description	Length	Item#	EACH Prices		
			1-2	3-9	10+
<b>G. Style RR</b>	5½"	<b>195-1300</b>	<b>\$5.85</b>	<b>\$5.27</b>	<b>\$4.97</b>
<b>H. Style MM</b>	5"	<b>195-1200</b>	<b>5.85</b>	<b>5.27</b>	<b>4.97</b>



**I Economical Tweezers**

Economical steel tweezers. Hand-finished tips have smooth points. Suitable for working with miniature parts under low magnification. Measure 5" long.

Description	Item#	EACH Prices		
		1-2	3-9	10+
Economical Tweezers	<b>195-1350</b>	<b>\$2.89</b>	<b>\$2.60</b>	<b>\$2.46</b>



**J Plastic Tweezers**

Synthetic nonconductive tweezers ideal for nonmarring use. Measure 5" long.

Description	Item#	EACH Prices		
		1-2	3-9	10+
Plastic Tweezers	<b>195-3262</b>	<b>\$ .99</b>	<b>\$ .89</b>	<b>\$ .84</b>





**A**

### A Ceramic Tip Tweezers

These lightweight tweezers feature zirconia ceramic tips attached to an aluminum body. Extremely smooth surface. 100% nonmagnetic, 100% nonrusting and nonstatic. Acid-resistant. Six times harder than stainless steel, twice as hard as carbon steel. Tips measure 1¼" long.

Style	Length	Item#	Each
A. Fine	5¼"	<b>195-3286</b>	<b>\$69.00</b>



**B**

### B Stand-Up Cross-Locking Tweezers

Free hands for soldering. Tweezers lie flat to hold piece about one inch off soldering board. Jaws are serrated. Made of stainless steel. Measure 6¼" long.

Description	Item#	EACH Prices		
		1-2	3-9	10+
Stand-Up Cross-Locking Tweezers	<b>195-0325</b>	<b>\$4.15</b>	<b>\$3.74</b>	<b>\$3.53</b>



**C**



**D**



**E**

### C - E Cross-Locking Tweezers

Tips close automatically when pressure is released from the handles. Most often used to hold objects for soldering but also used in a variety of general industrial applications. Excellent heat sink when soldering. Jaws of 4¾" tweezers are smooth; jaws of 6½" tweezers are serrated. Nickel-plated.

Points	Length	Item#	EACH Prices		
			1-2	3-9	10+
C. Pointed	4¾"	<b>195-1375</b>	<b>\$2.89</b>	<b>\$2.60</b>	<b>\$2.46</b>
D. Blunt	6½"	<b>195-1400</b>	<b>2.95</b>	<b>2.66</b>	<b>2.51</b>
E. Pointed	6½"	<b>195-1450</b>	<b>2.95</b>	<b>2.66</b>	<b>2.51</b>



**F**



**G**

### F, G Insulated Cross-Locking Tweezers

Similar to standard cross-locking tweezers, but handles are insulated to protect hands from heat of soldering flame. Jaws are serrated. Made of stainless steel. Measure 6¾" long.

Points	Item#	EACH Prices		
		1-2	3-9	10+
F. Straight	<b>195-2050</b>	<b>\$4.15</b>	<b>\$3.74</b>	<b>\$3.53</b>
G. Curved	<b>195-2075</b>	<b>4.15</b>	<b>3.74</b>	<b>3.53</b>



**H**

### H Vacuum Tweezers Set

Offers more precision and speed than standard tweezers. Includes mini vacuum generator with in-line on/off switch, anodized aluminum handpiece, five stainless steel suction tips and 4' of flexible air tubing with in-line filter. Rubber Cup Accessory Set sold separately (see below).

Vacuum generator can be adjusted from 1" to 15" Hg for picking up an infinite variety of small parts. Airflow: 125 cu. in./min. Electrical: 110V. Measures 2¾" dia. x 4½"H. Comfortable pencil-like handpiece is designed for simple operation: place finger over hole in back to create vacuum, and lift off to break vacuum. Weighs just ½ oz.

Description	Item#	Each
Vacuum Tweezers Set	<b>195-3300</b>	<b>\$136.00</b>



**I**

### I Rubber Cup Accessory Set

Eight-piece set of neoprene cups for use with Vacuum Tweezers Set (see above). Fit onto suction tips for picking up larger items. Range from ⅜" to ⅝" by ⅛" increments.

Description	Item#	Each
Rubber Cup Accessory Set	<b>195-3301</b>	<b>\$26.20</b>

**A Double Third Hand**

Round weighted base with cross bar, two spring-loaded alligator clips and multiple ball joints for infinite positioning ability. Frees both hands for work. Other accessories such as cross-locking tweezers may be added to increase the versatility of this convenient holding tool.

Description	Item#	Each
Double Third Hand	<b>816-1900</b>	<b>\$15.85</b>



**B Third Hand**

Cross-locking tweezers, 6½" long, mounted on a heavy nontipping round base. Base's ball-joint attachment permits angling of tweezers in any direction for most convenient working position. Frees hands for work. Handy for positioning pieces to be joined by solder or adhesive. Ideal for soldering difficult pieces. Comes complete with cross-locking tweezers #195-1400 (see previous page).

Description	Item#	Each
Third Hand	<b>816-1800</b>	<b>\$11.65</b>



**C Four-Prong Holder**

Press on plunger to open the four prongs, then release to hold small objects securely.

Description	Item#	EACH Prices		
		1-2	3-9	10+
Four-Prong Holder	<b>840-4451</b>	<b>\$5.95</b>	<b>\$5.65</b>	<b>\$5.36</b>



**D Long-Reach Tweezers**

Ideal for holding pieces for cleaning. Heat-resistant plastic-covered tips grip workpiece firmly without scratching. Made of chrome-plated stainless steel. Measure 10" long.

Description	Item#	EACH Prices		
		1-2	3-9	10+
Long-Reach Tweezers	<b>195-1900</b>	<b>\$7.95</b>	<b>\$7.16</b>	<b>\$6.76</b>

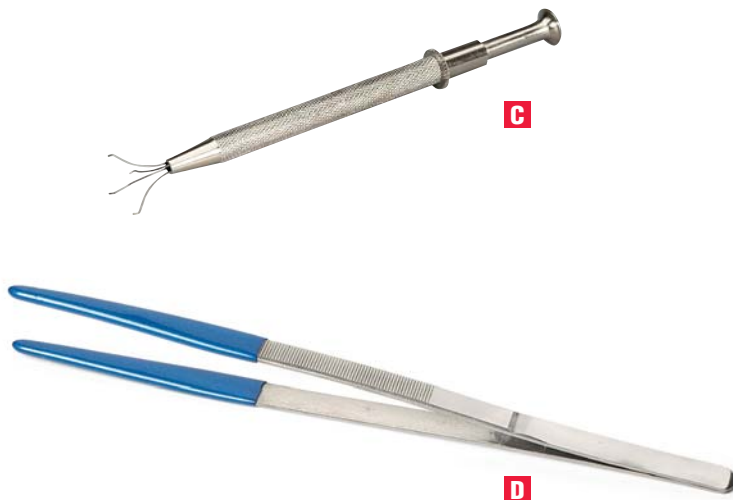

**E Demagnetizer/Magnetizer**

Intermittent-use electric tool perfect for demagnetizing and magnetizing tweezers, screwdrivers and other small tools and parts. Features a high power-to-weight ratio and unbreakable plastic housing. Opening measures 3"W x 1½"H. Electrical: 120V, 300W.

Description	Item#	Each
Demagnetizer/Magnetizer	<b>813-2100</b>	<b>\$55.00</b>



## Lindstrom® Swedish Pliers and Nippers

Made of drop-forged Swedish steel and precision-ground. Cushion grips and spring-loaded handles provide comfort for performing repetitive work while reducing hand fatigue. It's hard to beat the precise manufacturing quality, performance and durability of Lindstrom Pliers and Nippers. All are backed by a lifetime warranty.

When using Lindstrom Nippers, keep the following in mind.

1. Never use the nippers to cut something beyond the stated capacities printed on their handles.
2. Nippers must be adjusted so that their cutting edges are properly aligned and do not wobble, or else the edges can break.
3. If the handles bend toward one another, too great a force is being used. The wire being cut is either too hard or too large in diameter and can result in jaw breakage.



### A - E Lindstrom® Diagonal Nippers with Adjustable Screw Lap Joints

Exceptionally high-quality cutters for electronics and other industries. These nippers have been designed to access narrow, confined spaces. Cutting edges are precision-ground for cutting accuracy and black oxidized. All nippers have adjustable screw lap joints and return springs as well as yellow plastic grips. Designed for long life.

#### A Ultra-Flush Small Diagonal Nipper

Cuts 0.1–1.0mm copper wire. Measures 4<sup>1</sup>/<sub>3</sub>" long.

Description	Jaw Size (L x W)	Item#	Each
Ultra-Flush Small Nipper	3/8" x 3/8"	<b>182-8142</b>	<b>\$58.20</b>

#### B Flush Small Diagonal Nipper

Cuts 0.1–1.25mm copper wire. Measures 4<sup>1</sup>/<sub>3</sub>" long.

Description	Jaw Size (L x W)	Item#	Each
Flush Small Nipper	3/8" x 3/8"	<b>182-8141</b>	<b>\$44.10</b>

#### C Semi-Flush Small Diagonal Nipper

Cuts 0.2–1.25mm copper or 0.1–0.6mm iron wire. Measures 4<sup>1</sup>/<sub>3</sub>" long.

Description	Jaw Size (L x W)	Item#	Each
Semi-Flush Small Nipper	3/8" x 3/8"	<b>182-8140</b>	<b>\$42.95</b>

#### D Semi-Flush Medium Diagonal Nipper

Cuts 0.3–1.6mm copper, 0.2–0.8mm iron or 0.1–0.4mm piano wire. Measures 4<sup>7</sup>/<sub>16</sub>" long.

Description	Jaw Size (L x W)	Item#	Each
Semi-Flush Medium Nipper	1/2" x 1/2"	<b>182-8150</b>	<b>\$44.35</b>

#### E Semi-Flush Large Diagonal Nipper

Cuts 0.4–2.0mm copper, 0.3–1.2mm iron or 0.1–0.4mm piano wire. Measures 5" long.

Description	Jaw Size (L x W)	Item#	Each
Semi-Flush Large Nipper	5/8" x 5/8"	<b>182-8160</b>	<b>\$44.25</b>



**A - G Lindstrom® Lightweight Pliers and Nippers**

A wide selection of the finest quality lightweight pliers and nippers. All are precision-ground and have spring-loaded handles with white plastic grips.

**A Chain Pliers**

Have box joint and precision-ground jaws. Measure 4<sup>3</sup>/<sub>4</sub>" long.

Description	Jaw Size (L x W)	Item#	Each
Chain Pliers	3/4" x 1/32"	<b>182-7893</b>	<b>\$41.60</b>

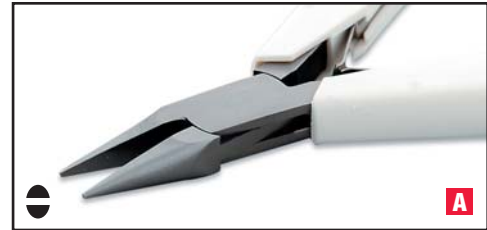

**B Flat Pliers**

Have box joint and precision-ground jaws. Measure 4<sup>3</sup>/<sub>4</sub>" long.

Description	Jaw Size (L x W)	Item#	Each
Flat Pliers	3/4" x 1/8"	<b>182-7490</b>	<b>\$36.75</b>

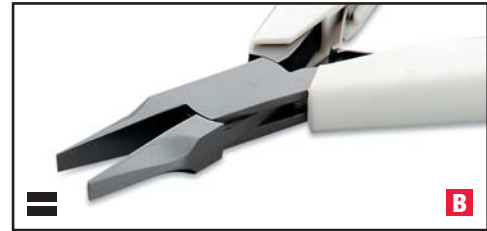

**C Round Pliers**

Have box joint and perfectly round precision-ground jaws. Ideal for making loops, bends and coils. Taper to 1/32". Measure 4<sup>3</sup>/<sub>4</sub>" long.

Description	Jaw Size (L x W)	Item#	Each
Round Pliers	3/4" x 1/32"	<b>182-7590</b>	<b>\$38.85</b>



**D Long-Nose Chain Pliers**

Have box joint and precision-ground jaws. Measure 5<sup>1</sup>/<sub>4</sub>" long.

Description	Jaw Size (L x W)	Item#	Each
Long-Nose Chain Pliers	1 1/4" x 1/32"	<b>182-7890</b>	<b>\$41.60</b>



**E Flush Diagonal Nipper – Gate Cutter**

Flush-cutting nipper with screw lap joint and tapered, relieved head for reaching tight areas. Cuts 28–18 AWG or 0.35–1.0mm dia. copper or annealed 14K gold wire. Measures 4<sup>1</sup>/<sub>3</sub>" long.

Description	Jaw Size (L x W)	Item#	Each
Flush Diagonal Nipper	3/8" x 3/8"	<b>182-7191</b>	<b>\$48.25</b>



**F Flush Oblique Nipper – Gate Cutter**

Flush-cutting nipper with box joint and 11°-angle head with one rounded end and one pointed end. Cuts 28–18 AWG or 0.35–1.0mm dia. copper or annealed 14K gold wire. Measures 4<sup>1</sup>/<sub>4</sub>" long.

Description	Jaw Size (L x W)	Item#	Each
Flush Oblique Nipper	9/16" x 1/3"	<b>182-7291</b>	<b>\$47.35</b>



**G Flush Relieved Oblique Nipper – Gate Cutter**

Flush-cutting nipper with box joint and 11°-angle relieved head for reaching tight areas. Cuts 28–18 AWG or 0.35–1.0mm dia. copper or annealed 14K gold wire. Measures 4<sup>1</sup>/<sub>4</sub>" long.

Description	Jaw Size (L x W)	Item#	Each
Flush Relieved Oblique Nipper	3/8" x 1/3"	<b>182-7293</b>	<b>\$54.95</b>





## A - K Teborg Pliers and Nippers

Feature precision-ground jaws, box or adjustable screw lap joints, dual leaf springs and hardened, treated handles with comfort grips. Will not break with proper use. Made in Sweden.

### A Chain Pliers

Measure 4<sup>3</sup>/<sub>4</sub>" long.

Description	Jaw Size (L x W)	Item#	Each
Chain Pliers	20 x 9mm	<b>182-9893</b>	<b>\$33.95</b>

### B Flat Pliers

Measure 4<sup>3</sup>/<sub>4</sub>" long.

Description	Jaw Size (L x W)	Item#	Each
Flat Pliers	20 x 9mm	<b>182-9490</b>	<b>\$32.25</b>

### C Round Pliers

Measure 4<sup>3</sup>/<sub>4</sub>" long.

Description	Jaw Size (L x W)	Item#	Each
Round Pliers	20 x 9mm	<b>182-9590</b>	<b>\$33.95</b>

### D Long-Nose Chain Pliers

Measure 5<sup>1</sup>/<sub>4</sub>" long.

Description	Jaw Size (L x W)	Item#	Each
Long-Nose Chain Pliers	32 x 9mm	<b>182-9890</b>	<b>\$33.95</b>

### E Bent Chain Pliers

Measure 5" long.

Description	Jaw Size (L x W)	Item#	Each
Bent Chain Pliers	29 x 9mm	<b>182-9892</b>	<b>\$33.95</b>

### F Bevel Diagonal Nipper

Cuts 0.35–1.25mm soft wire. Measure 4<sup>3</sup>/<sub>8</sub>" long.

Description	Jaw Size (L x W)	Item#	Each
Bevel Diagonal Nipper	9.5 x 9mm	<b>182-9190</b>	<b>\$38.20</b>

### G Bevel Oblique Nipper

Cuts 0.35–1.0mm soft wire. Measure 4<sup>3</sup>/<sub>8</sub>" long.

Description	Jaw Size (L x W)	Item#	Each
Bevel Oblique Nipper	8 x 9mm	<b>182-9291</b>	<b>\$43.10</b>

### H Semi-Flush Small Nipper

Cuts 0.1–1.25mm soft wire. Measure 4<sup>3</sup>/<sub>8</sub>" long.

Description	Jaw Size (L x W)	Item#	Each
Semi-Flush Small Nipper	9.5 x 9mm	<b>182-9141</b>	<b>\$36.50</b>

### I Bevel Small Nipper

Cuts 0.2–1.25mm soft wire. Measure 4<sup>3</sup>/<sub>8</sub>" long.

Description	Jaw Size (L x W)	Item#	Each
Bevel Small Nipper	9.5 x 8.5mm	<b>182-9140</b>	<b>\$36.50</b>

### J Bevel Medium Nipper

Cuts 0.3–1.6mm soft wire. Measure 4<sup>1</sup>/<sub>2</sub>" long.

Description	Jaw Size (L x W)	Item#	Each
Bevel Med. Nipper	12.5 x 12mm	<b>182-9150</b>	<b>\$36.50</b>

### K Bevel Large Nipper

Cuts 0.4–2.0mm soft wire. Measure 5<sup>1</sup>/<sub>4</sub>" long.

Description	Jaw Size (L x W)	Item#	Each
Bevel Large Nipper	16 x 15mm	<b>182-9160</b>	<b>\$38.20</b>

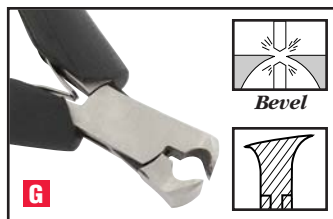

**A - I Standard-Weight Pliers and Nippers**

Feature box joints and plastic nonslip grips. Pliers have smooth jaws for holding work without marring. Nippers cut up to 1mm dia. copper or annealed 14K gold wire. Measure 5¼" long. Made in Germany.

**A Chain Pliers**

Description	Jaw Size (L x W)	Item#	Each
Chain Pliers	7/8" x 1/16" *	<b>180-1221</b>	<b>\$18.50</b>

\*Tapers to this width.

**B Flat Pliers**

Description	Jaw Size (L x W)	Item#	Each
Flat Pliers	1" x 3/16"	<b>180-1220</b>	<b>\$19.05</b>

**C Round Pliers**

Description	Jaw Size (L x W)	Item#	Each
Round Pliers	7/8" x 1/16" *	<b>180-1222</b>	<b>\$20.25</b>

\*Tapers to this diameter.

**D Half-Round/Flat Pliers**

Description	Jaw Size (L x W)	Item#	Each
Half-Round/Flat Pliers	7/8" x 5/16"	<b>180-1223</b>	<b>\$23.50</b>

**E Half-Round/Hollow Pliers**

Description	Jaw Size (L x W)	Item#	Each
Half-Round/Hollow Pliers	7/8" x 1/4"	<b>180-0215</b>	<b>\$25.20</b>

**F Round/Hollow Pliers**

Description	Jaw Size (L x W)	Item#	Each
Round/Hollow Pliers	7/8" x 1/16" *	<b>180-1235</b>	<b>\$26.65</b>

\*Tapers to this width.

**G Round/Flat Pliers**

Description	Jaw Size (L x W)	Item#	Each
Round/Flat Pliers	1" x 1/16"	<b>180-1230</b>	<b>\$25.90</b>

**H Rosary Pliers/Semi-Flush Nipper**

Description	Jaw Size (L x W)	Item#	Each
Rosary Pliers/Semi-Flush Nipper	1" x 1/16" *	<b>180-0217</b>	<b>\$28.10</b>

\*Tapers to this diameter.

**I Semi-Flush Diagonal Nipper**

Description	Jaw Size (L x W)	Item#	Each
Semi-Flush Diagonal Nipper	3/4" x 9/16"	<b>180-1250</b>	<b>\$29.25</b>

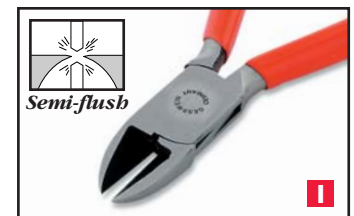
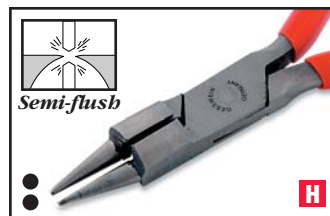



## A - E Foam-Grip Stainless Steel Pliers and Nipper

Economical stainless steel pliers and nipper with box joints and spring-loaded handles with extra-thick foam nonslip grips for secure, comfortable holding. Available individually and in a set of the four most popular shapes (see below). Measure 4½" long.

Description	Jaw Size (L x W)	Item#	EACH Prices		
			1-2	3-9	10+
A. Chain Pliers	7/8" x 1/16" *	<b>180-0330</b>	<b>\$8.85</b>	<b>\$7.97</b>	<b>\$7.37</b>
B. Flat Pliers	7/8" x 9/32"	<b>180-0331</b>	<b>8.85</b>	<b>7.97</b>	<b>7.37</b>
C. Round Pliers	3/4" x 1/16" *	<b>180-0332</b>	<b>8.85</b>	<b>7.97</b>	<b>7.37</b>
D. Bent Chain Pliers	7/8" x 1/16"	<b>180-0336</b>	<b>8.85</b>	<b>7.97</b>	<b>7.37</b>
E. Semi-Flush Diagonal Nipper	1/2"	<b>180-0333</b>	<b>14.85</b>	<b>13.37</b>	<b>12.37</b>
4-Piece Set (one of each except Bent Chain Pliers)		<b>180-0335</b>	<b>37.25</b>	-	-

\*Tapers to this width.

## F - H Parallel-Jaw Pliers

Feature jaws that stay parallel along their entire lengths whether opened or closed for positive grip of square and hexagonal components. Have nickel-plated sealed handles with anti-rust finish and fully heat-treated black jaws.

Available in two styles: flat and chain. Flat pliers come with smooth or serrated jaws that open to 7/16" (11mm). Serrated version has a single longitudinal V-slot. Chain pliers come with smooth jaws that open to 3/8" (10mm) and measure 3/32" (2mm) square at each tip.

Both styles allow wire to be fed through the throats from either end and held firmly over full jaw lengths. Packaged in vinyl sleeves for protection during shipping and storage. Measure 5" long.

Description	Item#	EACH Prices		
		1-2	3-9	10+
F. Flat Pliers with Smooth Jaws	<b>181-1035</b>	<b>\$19.15</b>	<b>\$18.19</b>	<b>\$17.04</b>
G. Flat Pliers with Serrated Jaws	<b>181-1030</b>	<b>18.25</b>	<b>17.34</b>	<b>16.24</b>
H. Chain Pliers with Smooth Jaws	<b>181-1060</b>	<b>25.05</b>	<b>23.80</b>	<b>22.29</b>

## I - K Palm Grip Pliers and Nipper

Small, lightweight stainless steel pliers and nipper ideal for working with small items. Feature perfectly aligned jaws with return springs for holding jaws open until handles are compressed. Pliers measure 4" long. Nipper measures 3½" long. Made in Japan.

Description	Jaw Size (L x W)	Item#	EACH Prices	
			1-2	3+
I. M-21 Chain Pliers	7/8" x 1/16"	<b>180-0265</b>	<b>\$13.00</b>	<b>\$11.70</b>
J. M-22 Bent Chain Pliers	7/8" x 1/16"	<b>180-0270</b>	<b>13.00</b>	<b>11.70</b>
K. M-17 Flush Nipper	1/4"	<b>180-0245</b>	<b>13.00</b>	<b>11.70</b>



**A - E Xuron Micro-Shear® Flush Cutters and Pliers**

Micro-Shear Flush Cutters feature a patented design that keeps blades sharper longer than conventional nippers. Blade edges bypass each other in a shearing motion rather than striking, resulting in clean square cuts with no spikes. Blades stay sharper and last much longer than conventional nippers because there is no edge-to-edge impact. Greatly reduce mechanical shock delivered to components and require roughly 50% less effort to cut wire than conventional compression-type wire cutters. Have ergonomically shaped, nonslip Xuro-Rubber comfort grips. Made in USA.

**A Xuron 9100 Micron-Shear® Flush Cutter**

Made of tough steel alloy with ultra-precise CNC grinding and state-of-the-art heat treating. Features oval head for added durability, Light Touch return spring and glare-free black finish. Comfortable for high-volume applications. Flush cuts soft wire up to 14 AWG (1.6mm). Measures 5" long.

Description	Jaw Size (L x W)	Item#	EACH Prices	
			1-2	3+
9100 Cutter	9 x 12.2mm	<b>181-0202</b>	<b>\$17.50</b>	<b>\$16.63</b>



**B Xuron 9200 Micron-Shear® Flush Cutter**

Made of tough steel alloy with ultra-precise CNC grinding and state-of-the-art heat treating. Features tapered head for cutting in high-density areas, Light Touch return spring and glare-free black finish. Comfortable for high-volume applications. Flush cuts soft wire up to 14 AWG (1.6mm). Measures 5" long.

Description	Jaw Size (L x W)	Item#	EACH Prices	
			1-2	3+
9200 Cutter	9 x 12.2mm	<b>181-0204</b>	<b>\$17.50</b>	<b>\$16.63</b>



**C Xuron 2175 Micron-Shear® Flush Cutter**

Features elongated and tapered head with extra-tough high-carbon steel blades for cutting in high-density areas. Has nonprotruding flat return spring for excellent feel without excessive tension and glare-free black finish. Flush cuts soft wire up to 14 AWG (1.6mm). Measures 6" long.

Description	Jaw Size (L x W)	Item#	EACH Prices	
			1-2	3+
2175 Cutter	12 x 17mm	<b>181-0208</b>	<b>\$14.00</b>	<b>\$13.30</b>



**D Xuron LX Micron-Shear® Flush Cutter**

Features ultra-slim profile and tapered head with precision-ground, extra-tough high-carbon steel blades for cutting in high-density areas with maximum maneuverability. Perfect for small hands. Flush cuts soft wire up to 19 AWG (1.0mm). Measures 4.8" long.

Description	Jaw Size (L x W)	Item#	EACH Prices	
			1-2	3+
LX Cutter	9 x 14mm	<b>181-0200</b>	<b>\$14.00</b>	<b>\$13.30</b>



**E Xuron 450 Tweezer Nose™ Pliers**

Ultra-precise, durable needle nose pliers capable of grasping and holding wire less than 1mm thick with the strength for wire forming. Prevent leads from popping free, tip misalignment and blade crossover. Have radiused edges for protecting lead wires. Feature lightweight construction, Light Touch return spring and glare-free black finish. Measure 5" long.

Description	Jaw Size (L x W)	Item#	EACH Prices	
			1-2	3+
450 Pliers	20 x 10mm	<b>181-0206</b>	<b>\$14.15</b>	<b>\$13.44</b>







### A Bergeon Heavy-Duty Side Cutter

Special linkage of this top-quality side cutter multiplies your hand pressure many times to give a full, clean cut. Helps reduce hand fatigue from constant cutting. Extra-long handles provide additional leverage so cutting is easier. Hardened steel jaws have 7/8" (22mm) long cutting edges, which are protected by locking system. Cuts up to 4.5mm thick. Measures 10" long.

Description	Item#	Each
Bergeon Side Cutter	<b>181-4075</b>	<b>\$139.00</b>



### B Compound Cutter

Heavy-duty diagonal cutter with compound leverage action for easier cutting with less effort. Cuts brass rods up to B&S gauge 8. Insulated plastic grips. Measures 7 1/4" long with 7/16" long jaws. Made in Germany.

Description	Item#	EACH Prices		
		1-2	3-9	10+
Compound Cutter	<b>181-4060</b>	<b>\$38.95</b>	<b>\$37.00</b>	<b>\$35.06</b>



### C Nylon Jaw Pliers

These heavy-duty stainless steel pliers have box joints and plastic comfort grips. Replaceable nylon jaws grip firmly without marring. Easily customized by filing or carving. For general-purpose work. Measure 5 3/4" long with 1"L x 7/16"W jaws.

Description	Item#	Each
C. Nylon Jaw Pliers	<b>180-0001</b>	<b>\$13.95</b>
Replacement Jaws	180-0002	3.55



### D Loop Opening Pliers

Expanding pliers with heavy-duty spring that keeps them closed. Jaws open when handles are compressed. Handy for opening loops, true arc rings and more. Measure 6 3/4" long with 2 1/4" long jaws that taper to 3/32" at the tips. Made in Germany.

Description	Item#	EACH Prices		
		1-2	3-9	10+
Loop Opening Pliers	<b>180-0150</b>	<b>\$39.05</b>	<b>\$35.15</b>	<b>\$31.24</b>



### E - H Lightweight Metal Snips

For cutting templates and patterns from medium-hard sheet metal up to B&S 20 or soft sheet up to B&S 16. Available with either curved blades for cutting circular shapes or straight blades for straight cuts. Also choose from plain or looped handles. Weigh only 4 oz. Measure 7" long with 1 1/2" long blades.

Handles	Blades	Item#	Each
E. Plain	Curved	<b>819-0050</b>	<b>\$13.45</b>
F. Plain	Straight	<b>819-0100</b>	<b>13.75</b>
G. Looped	Curved	<b>819-0200</b>	<b>10.90</b>
H. Looped	Straight	<b>819-0150</b>	<b>12.25</b>



**A Steamostat**

A perfect holder for steam and ultrasonic cleaning. Stainless steel box-joint construction with nonscratching PVC coating on straight tips. Three-position lockable handle prevents slipping. Measures 7¼" long.

Description	Item#	EACH Prices		
		1-2	3-9	10+
Steamostat	<b>181-5010</b>	<b>\$6.25</b>	<b>\$5.94</b>	<b>\$5.31</b>



**B, C Hemostats**

Precision pointed holding tools with two-position self-locking handles. Highly polished stainless steel. Box-joint construction. Heat-resistant handles. Serrated jaws grip securely but do not cut into soft materials. Ideal for holding small items that are to be soldered. Measure 6" long.

Description	Item#	EACH Prices	
		1-2	3+
<b>B. Curved</b>	<b>181-5000</b>	<b>\$6.50</b>	<b>\$5.85</b>
<b>C. Straight</b>	<b>181-5005</b>	<b>6.50</b>	<b>5.85</b>

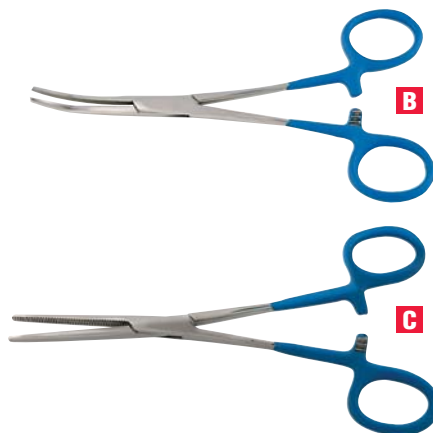

**D Screwdriver Set**

Includes six precision screwdrivers with replaceable blades that are held firmly in the handles by screw chucks. Blades are made of the finest heat-treated tool steel for toughness and longevity. Hexagonal heads will not roll on bench. Bodies are plated and have a knurled grip for nonslip holding. Screwdrivers measure approx. 4" long. Made in USA.

Description	Item#	Each
<b>D. Screwdriver Set</b>	<b>820-9000</b>	<b>\$19.60</b>
Replacement Blade	Item#	Each
.100"	820-9001*	\$1.95
.080"	820-9002*	1.95
.070"	820-9003*	1.95
.055"	820-9004*	1.95
.040"	820-9005*	1.95
.025"	820-9006*	1.95



\*Three-piece minimum; please order in multiples of three.

**E Screwdriver Set with Rotating Stand**

Includes nine color-coded setscrew screwdrivers, 19 spare blades, two extra setscrews and rotating stand for easy access and compact storage. Made in France.

Description	Item#	Each
<b>E. Screwdriver Set with Stand</b>	<b>820-9010</b>	<b>\$43.05</b>
Replacement Blades	Item#	Pkg. of 3
0.60mm	820-9011	\$1.10
0.80mm	820-9012	1.10
1.00mm	820-9013	1.10
1.20mm	820-9014	1.10
1.40mm	820-9015	1.37
1.60mm	820-9016	1.37
2.00mm	820-9017	1.37
2.50mm	820-9018	1.49
3.00mm	820-9019	1.49





**A**



**B**



**C**



**D**



**E**



**F**



**G**



**H**



**I**



**J**

## A - I Pin Vises

A wide selection for holding small drills, wires, taps, screwdriver blades and more.

Description	Length	Item#	EACH Prices	
			1-2	3+
<b>A.</b> 5/8" wide jaws, hollow handle, opens to 1/4", 3/16" gap.	4 1/2"	<b>820-4150</b>	<b>\$26.25</b>	<b>\$24.94</b>
<b>B.</b> Dog-nosed 5/16" wide jaws, hollow handle, opens to 1/4", 3/16" gap.	4 1/2"	<b>820-4050</b>	<b>27.50</b>	<b>26.13</b>
<b>C.</b> Extra screw and nut for #820-4150 and #820-4050.	—	<b>820-4100</b>	<b>6.15</b>	<b>5.84</b>
Description	Length	Item#	EACH Prices	
<b>D.</b> Double-ended with different size steel collets mounted in both ends of hollow handle. Capacity: 0"—0.099".	4 1/4"	<b>820-4650</b>	<b>\$8.95</b>	<b>\$8.50</b> <b>\$8.06</b>
<b>E.</b> Double-ended with reversible steel collets. Capacity 0"—0.125"	4 1/4"	<b>820-4350</b>	<b>5.95</b>	<b>5.65</b> <b>5.36</b>
<b>F.</b> Two steel chucks with hollow brass handle. Capacity 0"—0.079".	3 3/4"	<b>820-4300</b>	<b>5.50</b>	<b>5.23</b> <b>4.95</b>
<b>G.</b> Steel chuck with hollow wooden handle. Capacity 0"—0.064".	4 1/4"	<b>820-4250</b>	<b>5.59</b>	<b>5.31</b> <b>5.03</b>
<b>H.</b> Swivel head pin vise for drilling or tapping. Two double-ended chucks. Capacity: 0"—0.125".	3 1/2"	<b>820-4355</b>	<b>5.95</b>	<b>5.65</b> <b>5.36</b>
<b>I.</b> Sliding pin vise for one-handed operation. Single end has knurled slide. Capacity: 0"—0.032".	4 1/2"	<b>820-4260</b>	<b>4.55</b>	<b>4.32</b> <b>4.10</b>

## J Precision Pin Vise Set

Includes four precision pin vises for holding a wide variety of items. Tool steel collets and hollow chromium-plated handles accommodate long wires or rods. Specially designed stepped bodies allow vises to be held securely in lathe or drill press or used by hand. Made in USA. See p. 186 for adapter chucks.

### Specifications:

Collet Capacity	
3" Vise	0"—0.040"
3 1/4" Vise	0.025"—0.062"
3 7/8" Vise	0.050"—0.125"
4 1/4" Vise	0.115"—0.188"

Description	Item#	EACH Prices	
		1-2	3+
Precision Pin Vise Set	<b>820-4175</b>	<b>\$29.25</b>	<b>\$27.79</b>



**K**

## K Steel Hand Vise

Has spring action in handle to keep jaws open. Measures 4" long with 1 1/4" wide serrated jaws that open to 1".

Description	Item#	EACH Prices	
		1-2	3+
Steel Hand Vise	<b>820-4500</b>	<b>\$21.55</b>	<b>\$20.47</b>

**A PanaVise® Model 381**

An all-purpose vise that tilts, turns and rotates. Vise head can be turned 360°, tilted 90° and locked in any position. When head is locked as desired, stem can also be rotated or locked in place. One convenient variable-pressure knob controls all movement. Nonmarring nylon jaws open to 2½". A half-turn of the mount lever permits easy mounting of the vise on any smooth, nonporous surface; suction holds vise to surface until level is released.

Description	Item#	Each
<b>A.</b> Panavise Model 381	<b>814-0190</b>	<b>\$57.75</b>
Replacement Nylon Jaws, set of two	814-0805	2.79



**B PanaVise® Model 301**

An all-purpose vise that tilts, turns and rotates. Vise head can be turned 360°, tilted 90° and locked in any position. When head is locked as desired, stem can also be rotated or locked in place. One convenient variable-pressure knob controls all movement. Nonmarring nylon jaws open to 2½".

Description	Item#	Each
<b>B.</b> Panavise Model 301	<b>814-0200</b>	<b>\$44.80</b>
Replacement Nylon Jaws, set of two	814-0805	2.79



**C Base Mount #311 for Panavise Model 301**

Platform base mount for securing Panavise Model 301 to the edge of a workbench or counter. Uses a clamp screw that opens to a maximum of 3½" (89mm). Comes with three screws for attachment to Panavise.

Description	Item#	Each
Base Mount #311	<b>814-0700</b>	<b>\$39.95</b>



**D Freedom® Soff Jaws™ Bench Vise Pads**

Resilient cushioned pads with magnetic strips for mounting on bench vise jaws. Grip irregular and delicate objects firmly without marring finished surfaces. Measure 3½" wide. Fit best on 3", 3½" and 4" wide vises but can also be mounted on wider ones.

Description	Item#	Pair
Soff Jaws	<b>820-4705</b>	<b>\$7.95</b>



**E V-Block Visers**

These precision vises hold round parts firmly and accurately for drilling, milling, grinding and inspection. Feature unique design that prevents deformity caused by other gripping mechanisms. Can be mounted in a milling vise, machine table, angle plate or magnetic chuck. Virtually all methods of mounting permit vertical, horizontal or angular use.

Description	Capacity	Item#	Each
Mark III	1/16"-1 1/16" dia.	<b>819-5005</b>	<b>\$140.00</b>
<b>E.</b> Mark IV	1/16"-1 1/8" dia.	<b>819-5010</b>	<b>175.00</b>
Mark V	1/4"-3 1/2" dia.	<b>819-5015</b>	<b>875.00</b>

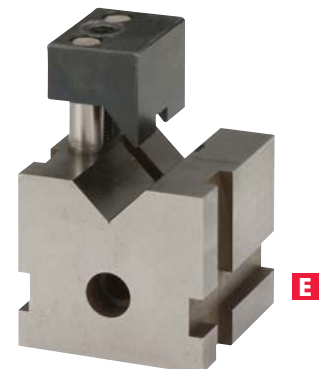





**A**

## **A Pin Grinding Fixture**

This unique precision-machined fixture is used on your surface grinder for accurately holding and positioning pins and ejector pins for quick and easy cutoff and grinding. The 1½" wide linear pin grip holds 1/16"-3/4" dia. pins firmly. Pressure is spread out over the entire width of the grip, eliminating grinding chatter and dents in pins that normally occur when using a single-point V-block.

Pins 14" and longer are easily and accurately ground to length. Can be used in horizontal position for end grinding or attached to angle iron for vertical use and face grinding. Measures only 3½" high with 4½"W x 3"D base.

Description	Item#	Each
Pin Grinding Fixture	<b>819-5000</b>	<b>\$369.00</b>



**B**

## **B Rotating Bench Vise**

Sturdy high-quality vises especially suited for tool and die makers and for electronic and general metalworking. The vise head can be rotated a full 360° and tilted from a flat 180° horizontal to a full 90° vertical, then locked securely in place, allowing your workpiece to be easily swiveled and angled into the best working position. Supplied with steel jaws. Optional nylon jaws are available. One side of the steel jaws has two V-shaped grooves for holding wire and round or tube stock. Movable vise jaw slides in a brass guide. Jaw clamping screw and joint locking screw work on bronze lead nuts.

Choose from two models: one has 1½" jaws and 3" clamping range, and other has 3¼" jaws and 4½" clamping range. Each includes base mount with clamp screw for secure mounting on the edge of a workbench or counter up to 3" thick. Base mount can also be removed for fixing the vise with screws directly to benchtop.

Bench Vise Jaw Width	Clamping Range	Clamping Height	Net Wt.	Item#	Each
<b>B.</b> 1½" (46mm)	3" (75mm)	1¾" (35mm)	4 lbs.	<b>820-4056</b>	<b>\$202.75</b>
3¼" (82mm)	4½" (105mm)	2¾" (56mm)	14 lbs.	<b>820-4058</b>	<b>\$399.00</b>
Optional Nylon Jaws for #820-4056				<b>820-4060</b>	<b>48.65</b>
Optional Nylon Jaws for #820-4058				<b>820-4062</b>	<b>51.40</b>

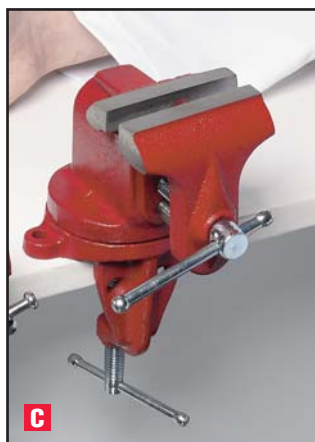

**C**

## **C Swivel Bench Vise**

Dual guide rods ensure parallel closing of jaws, rigidity and steady action. Smooth jaws help prevent marring of soft metal. Features sturdy cast iron body with anvil top and enamel finish. Fits benchtops up to 2" thick. Can be rotated laterally 360° and locked in position. Jaws are 2½" wide and open to 2½".

Description	Item#	Each
Swivel Bench Vise	<b>820-4054</b>	<b>\$46.20</b>



**D**

## **D Mini Bench Vise**

Great for small items. Features sturdy cast iron body with anvil top and enamel finish. Fits benchtops up to 1½" thick. Jaws are 1" wide and open to 1".

Description	Item#	Each
Mini Bench Vise	<b>820-4052</b>	<b>\$7.40</b>



**A, B Economy Sandblasters**

These compact recirculating units feature solid molded construction for eliminating annoying leaks, large viewing glass, adjustable pressure regulator and self-cleaning nozzle with easily replaceable orifice. Available in two styles: Single has left-hand heavy-duty rubber glove and manual blast control; Dual has left- and right-hand heavy-duty rubber gloves and foot pedal blast control. Each sits comfortably atop the workbench. Can be easily moved when not in use. Includes two replacement ceramic orifices for years of dependability, internal lightbulb and 5 lbs. of quartz abrasive. Air requirement: 25–100 PSI at 2.4 CFM. Measures just 11½"W x 12"D x 18"H. Ship. wt: 18 lbs.

Description	Electrical	Item#	Each
<b>A.</b> Single Sandblaster	110V, 50/60Hz	<b>854-0050</b>	<b>\$464.00</b>
	220V, 50/60Hz	<b>854-0055</b>	<b>475.00</b>
<b>B.</b> Dual Sandblaster	110V, 50/60Hz	<b>854-0060</b>	<b>530.00</b>
	220V, 50/60Hz	<b>854-0065</b>	<b>535.00</b>
Replacement Plexiglas Door		854-0056	26.75
Replacement Nozzle Assembly Kit (two ceramic orifices and two setscrews)		854-0057	18.15
Replacement Gloves, pair		854-1278	11.40



**C - G Sandblasting Medias**

Choose from five different medias: Crushed Ruby (man-made ruby for a matte finish with a subtle sparkle), Jet Brite (silicon-coated glass for a satin finish), Glass Beads in small and large sizes (for a satin finish) and Aluminum Oxide (for deburring).

Description	Size Range (microns)	Max. Pressure (PSI)	Qty. (lbs.)	Item#	Each
<b>C.</b> Crushed Ruby	212–300	80	5	<b>854-1297</b>	<b>\$95.00</b>
<b>D.</b> Jet Brite	50–105	45	5	<b>810-1200</b>	<b>19.65</b>
<b>E.</b> Sm. Glass Beads	50	45	11	<b>854-0104</b>	<b>35.00</b>
<b>F.</b> Lg. Glass Beads	100	45	25	<b>854-1292</b>	<b>64.95</b>
			1	<b>854-1294</b>	<b>18.65</b>
<b>G.</b> Aluminum Oxide	90	Low–high	1	<b>854-1294</b>	<b>18.65</b>



**H, I Power Sandblaster #20**

This heavy-duty sandblaster uses a 6 CFM gun jet for powerful blasting. Features 14-gauge welded steel construction, front-opening door with double-laminated safety viewing glass, spacious work chamber for holding large parts, durable rubber gloves, fluorescent light and trapdoor for easy media removal. Holds and automatically recycles up to 20 lbs. of media. Removes fine dust particles via a built-in dust collector with easily replaceable dust filter for clean, safe operation. Includes foot control and pressure regulator with gauge. Can be mounted on a bench or on an optional stand. Accepts optional pencil gun attachment for micro-blasting and 12 CFM gun jet for doubling power (requires 3 HP air compressor).

**Specifications:**

Airflow	6 CFM (12 CFM with jet)
Air Compressor	1½ HP (3 HP with jet)
Dimensions	
Overall	21"W x 18½"D x 38½"H
Inside	20"W x 18"D x 18"H
Door Opening	20"W x 15"H
Viewing Glass	18"W x 10"H
Dust Collector	15" dia. x 24"H
Ship. Wt.	165 lbs.

Description	Electrical	Item#	Each
<b>H.</b> Power Sandblaster #20	115V, 1 Ph, 60Hz	<b>854-0015</b>	<b>\$615.00</b>
	Power Sandblaster #20	230V, 1 Ph, 50/60Hz	<b>854-0016</b>
<b>I.</b> Optional Stand with Swing-out Shelf		<b>854-0025</b>	<b>165.00</b>
Optional Pencil Gun Attachment		<b>854-0035</b>	<b>180.00</b>
Optional 12 CFM Gun Jet		<b>854-0034</b>	<b>13.75</b>
Replacement Viewing Glass Shields, pkg. of 10		854-0038	5.95
Replacement Dust Filter		854-0036	11.50
Replacement 24" Gloves, pair		854-0040	26.00

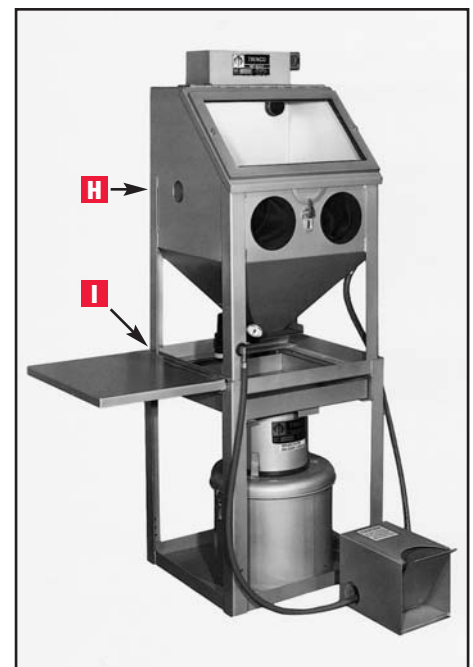



**A Foredom® Power Graver**

**For engraving, etching and marking molds and dies.**

The Foredom Power Graver is a flexible shaft machine specifically designed for hammering and power engraving on molds and dies. Requires no air compressor or special accessories. Uses standard gravers to give you the feel of hand engraving with less effort and fatigue. Includes a motor, manual speed controller, on/off foot switch and #9D hammer handpiece with duplex spring.

The permanently lubricated ball-bearing motor provides quiet, smooth-running operation. Features high torque at low speed to supply the power needed to work with most tool steels. Can also be used with many other types of hammer handpieces. Includes 39" long shaft with an extra-flexible neoprene sheath.

Benchtop manual speed controller allows infinite speed adjustment from 500 to 2,800 strokes per minute and keeps the speed you select constant. On/off foot switch permits stopping and starting without having to readjust speed.

The #9D handpiece includes three collets ( $\frac{1}{16}$ ",  $\frac{3}{32}$ " and  $\frac{1}{8}$ ") for holding different sizes and shapes of gravers and other tools, convenient adjusting ring for changing impact force and palm rest for comfortable operation. Cannot be used with any other flex shaft motor.

Description	Electrical	Item#	Each
Power Graver	110V	<b>821-6725</b>	<b>\$395.00</b>
	220V	<b>821-6730</b>	<b>395.00</b>

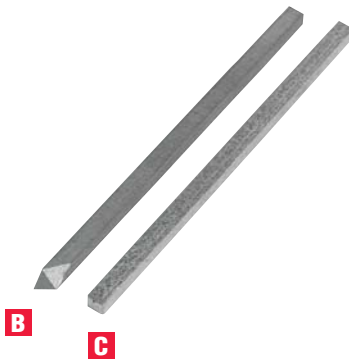

**B, C Carbide Gravers**

Made of a special grade of extra-fine-grain carbide that withstands impact better than any other grade. Use with Foredom Power Graver (see above). Sharpen with Power Hone (see p. 252) and diamond wheel. Square graver has one end angled at 45°. Blank graver is unground and can be custom-shaped. Both measure just under  $\frac{3}{32}$ " square x 2" long.

Description	Item#	Each
<b>B.</b> Carbide Square	<b>856-0292</b>	<b>\$9.90</b>
<b>C.</b> Carbide Blank	<b>856-0290</b>	<b>9.40</b>



**D, E GlenSteel Gravers**

Made of special high-speed tool steel, these gravers stay sharp longer and resist breakage better than other gravers and tools. Ideal for tough metalworking applications. Easier to grind and cobalt-free for improved safety. Use with Foredom Power Graver (see above). Sharpen with Power Hone (see p. 252) and diamond wheel. Both measure 0.093" square x 2.7" long.

Description	Item#	Each
<b>D.</b> GlenSteel Square	<b>856-0001</b>	<b>\$11.45</b>
<b>E.</b> GlenSteel Flat	<b>856-0002</b>	<b>11.45</b>

**A Steel Number Stamp Set**

Includes nine steel stamps for making numbers zero through nine (the nine is used upside down to make the six). Impressions are 1/16" high. For use on metal surfaces up to 50 HRC. Packed in hardwood case with cover.

Description	Item#	Each
Steel Number Stamp Set	<b>190-0030</b>	<b>\$15.95</b>

**B Steel Letter Stamp Set**

Includes 27 steel stamps for making all letters of the alphabet plus a period. Impressions are 1/16" high. For use on metal surfaces up to 50 HRC. Packed in hardwood case with cover.

Description	Item#	Each
Steel Letter Stamp Set	<b>190-0010</b>	<b>\$47.95</b>



**C Dremel® Electric Engraver**

Economical, adjustable engraver for personalizing or marking valuable articles made of metal, wood, plastic, ceramic, glass or leather. Features handy hanger for convenient storage, calibrated stroke adjustment dial, comfortable pencil-type grip and easily replaceable carbide point. Optional diamond point available. Measures 6" long with 6' cord. Electrical: 115V, 0.2A, 60Hz. UL listed.

Description	Item#	Each
C. Electric Engraver	<b>821-6010</b>	<b>\$19.75</b>
Optional Diamond Point	<b>821-6020</b>	<b>14.87</b>
Replacement Carbide Point	821-6015	4.87



**D Chicago Pneumatic Air Scribe**

Writes as easily as a ballpoint pen on a variety of metals up to 64 HRC. Perfect for scribing numbers and letters. Includes carbide stylus and 8' reinforced hose. Requires less than 1 CFM of air. Measures 4 3/4"L x 5/8" dia. Weighs just 5 oz. Three optional tips available: Flat Chisel, for scaling and deburring; Round Chisel, for cleaning weld beads or inside radii; and Chisel Blank, which can be ground to custom shapes for special jobs. Use with Filter/Regulator-Lubricator (see p. 114).

Description	Item#	Each
D. Air Scribe	<b>850-7395</b>	<b>\$286.00</b>
Optional Flat Chisel	<b>850-7399</b>	<b>15.12</b>
Optional Round Chisel	<b>850-7397</b>	<b>14.75</b>
Optional Chisel Blank	<b>850-7398</b>	<b>6.30</b>
Replacement Carbide Stylus	850-7396	17.95



**E, F Magna-Graver® and Magna-Graver® II Vari-Pact™**

The Magna-Graver is a powerful impact handpiece that attaches to any standard flex shaft machine except Power Graver. Does scrollwork, florentining, bead raising, texturing and stippling on brass and steel. Accepts standard 1/8" round tools and 3/32" square high-speed steel, cobalt and carbide gravers. Runs at 80–1,600 strokes per minute.

Magna-Graver II Vari-Pact is the same handpiece with the addition of the Vari-Pact selector button, which lets the user choose from four different impact power settings that range from light to heavy. Offers better control of cutting action.

To protect handpieces from undue wear and tear and to increase control, use with a flex shaft motor that has a gear reduction, such as LX or LXB (see p. 101). Measure 5 1/4" long. Made in USA.

Description	Item#	Each
E. Magna-Graver	<b>821-6040</b>	<b>\$225.00</b>
F. Magna-Graver II Vari-Pact	<b>821-6042</b>	<b>325.00</b>
Graver Set for Magna-Gravers*	<b>821-6045</b>	<b>31.50</b>

\*Includes square, flat and liner gravers and round high-speed steel tool blank with 1/8" shanks.



# Hand Tools

## A Gesswein® High-Speed Steel Red-Tang Gravers

Made of high-speed steel. Generally preferred for use on most steels. Hold cutting edges four to five times longer than Swedish tool steel gravers.

## B Muller® Swedish Steel Gravers

Made of premium-grade Swedish steel pretempered for work on nonferrous metals. Can be retempered to suit individual requirements.

## C Gardon/Vallorbe Swiss High-Speed Steel Yellow-Tang Gravers

Made of high-speed steel specially melted and rolled just for gravers.

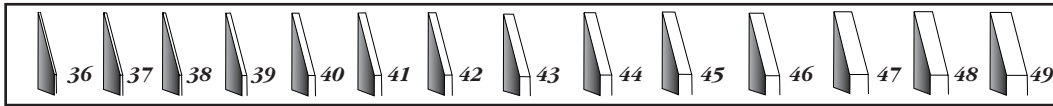

### Gesswein HS Flat

No.	Item#	EACH Prices	
		1-2	3+
36	166-1360	\$6.98	\$6.28
37	166-1370	6.98	6.28
38	166-1380	6.98	6.28
39	166-1390	6.98	6.28
40	166-1400	6.98	6.28
41	166-1410	6.98	6.28
42	166-1420	6.98	6.28
43	166-1430	6.98	6.28
44	166-1440	6.98	6.28
45	166-1450	6.98	6.28

### Muller Flat

No.	Item#	EACH Prices	
		1-2	3+
36	165-1360	\$5.70	\$5.13
37	165-1370	5.70	5.13
38	165-1380	5.70	5.13
39	165-1390	5.70	5.13
40	165-1400	5.70	5.13
41	165-1410	5.70	5.13
42	165-1420	5.70	5.13
43	165-1430	5.70	5.13
44	165-1440	5.70	5.13
45	165-1450	5.70	5.13
46	165-1460	5.70	5.13
47	165-1470	5.70	5.13
48	165-1480	5.70	5.13
49	165-1490	5.70	5.13

### Gardon/Vallorbe HS Flat

No.	Item#	Each
36	166-7210	\$8.35
37	166-7211	8.35
38	166-7212	8.35
39	166-7213	8.35
40	166-7214	8.35
41	166-7215	8.35
42	166-7216	8.35
43	166-7217	8.35

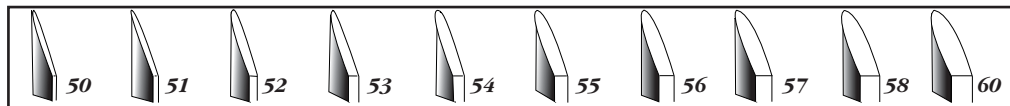

### Gesswein HS Round

No.	Item#	EACH Prices	
		1-2	3+
50	166-1500	\$6.98	\$6.28
51	166-1510	6.98	6.28
52	166-1520	6.98	6.28
53	166-1530	6.98	6.28
54	166-1540	6.98	6.28
55	166-1550	6.98	6.28
56	166-1560	6.98	6.28
57	166-1570	6.98	6.28

### Muller Round

No.	Item#	EACH Prices	
		1-2	3+
50	165-1500	\$5.70	\$5.13
51	165-1510	5.70	5.13
52	165-1520	5.70	5.13
53	165-1530	5.70	5.13
54	165-1540	5.70	5.13
56	165-1560	5.70	5.13
58	165-1580	5.70	5.13
60	165-1600	5.70	5.13

### Gardon/Vallorbe HS Round

No.	Item#	Each
50	166-7220	\$8.35
51	166-7221	8.35
52	166-7222	8.35
53	166-7223	8.35
54	166-7224	8.35

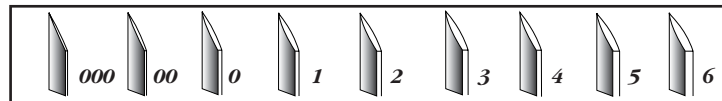

### Gesswein HS Point (Onglette)

No.	Item#	EACH Prices	
		1-2	3+
0	166-5001	\$6.98	\$6.28
1	166-5010	6.98	6.28
2	166-5020	6.98	6.28
3	166-5030	6.98	6.28
4	166-5040	6.98	6.28
5	166-5050	6.98	6.28

### Muller Point (Onglette)

No.	Item#	EACH Prices	
		1-2	3+
000	165-6003	\$5.70	\$5.13
00	165-6002	5.70	5.13
0	165-6001	5.70	5.13
1	165-6010	5.70	5.13
2	165-6020	5.70	5.13
3	165-6030	5.70	5.13
4	165-6040	5.70	5.13
5	165-6050	5.70	5.13

### Gardon/Vallorbe HS Point (Onglette)

No.	Item#	Each
2/0	166-7200	\$8.35
0	166-7201	8.35
1	166-7202	8.35
2	166-7203	8.35
3	166-7204	8.35
4	166-7205	8.35
5	166-7206	8.35
6	166-7207	8.35



**Gesswein® High-Speed Steel**

**Gesswein Half-Point Left  
not available**

**Gesswein Half-Point Right  
not available**

**Gesswein HS Bevel Edge**

No.	Item#	EACH Prices	
		1-2	3
1	<b>166-0010</b>	<b>\$6.98</b>	<b>\$6.28</b>
2	<b>166-0020</b>	<b>6.98</b>	<b>6.28</b>
3	<b>166-0030</b>	<b>6.98</b>	<b>6.28</b>

**Gesswein Oval  
not available**

**Gesswein HS Knife**

No.	Item#	EACH Prices	
		1-2	3
0	<b>166-4000</b>	<b>\$6.98</b>	<b>\$6.28</b>
1	<b>166-4010</b>	<b>6.98</b>	<b>6.28</b>
2	<b>166-4020</b>	<b>6.98</b>	<b>6.28</b>
3	<b>166-4030</b>	<b>6.98</b>	<b>6.28</b>
4	<b>166-4040</b>	<b>6.98</b>	<b>6.28</b>

**Gesswein Square  
not available**

**Gesswein Tapered Square  
not available**

**Muller® Swedish Steel**

**Muller Half-Point Left**

No.	Item#	EACH Prices	
		1-2	3+
0	<b>165-2001</b>	<b>\$5.70</b>	<b>\$5.13</b>
1	<b>165-2010</b>	<b>5.70</b>	<b>5.13</b>
2	<b>165-2020</b>	<b>5.70</b>	<b>5.13</b>
3	<b>165-2030</b>	<b>5.70</b>	<b>5.13</b>

**Muller Half-Point Right**

No.	Item#	EACH Prices	
		1-2	3+
0	<b>165-3001</b>	<b>\$5.70</b>	<b>\$5.13</b>
1	<b>165-3010</b>	<b>5.70</b>	<b>5.13</b>
2	<b>165-3020</b>	<b>5.70</b>	<b>5.13</b>
3	<b>165-3030</b>	<b>5.70</b>	<b>5.13</b>

**Muller Bevel Edge**

No.	Item#	EACH Prices	
		1-2	3+
0	<b>165-0001</b>	<b>\$5.70</b>	<b>\$5.13</b>
1	<b>165-0010</b>	<b>5.70</b>	<b>5.13</b>
2	<b>165-0020</b>	<b>5.70</b>	<b>5.13</b>
3	<b>165-0030</b>	<b>5.70</b>	<b>5.13</b>

**Muller Oval**

No.	Item#	EACH Prices	
		1-2	3+
63	<b>165-0630</b>	<b>\$5.70</b>	<b>\$5.13</b>
64	<b>165-0640</b>	<b>5.70</b>	<b>5.13</b>
65	<b>165-0650</b>	<b>5.70</b>	<b>5.13</b>

**Muller Knife**

No.	Item#	EACH Prices	
		1-2	3+
0	<b>165-4000</b>	<b>\$5.70</b>	<b>\$5.13</b>
1	<b>165-4010</b>	<b>5.70</b>	<b>5.13</b>
2	<b>165-4020</b>	<b>5.70</b>	<b>5.13</b>
3	<b>165-4030</b>	<b>5.70</b>	<b>5.13</b>
4	<b>165-4040</b>	<b>5.70</b>	<b>5.13</b>

**Muller Square**

No.	Item#	EACH Prices	
		1-2	3+
2	<b>165-7020</b>	<b>\$5.70</b>	<b>\$5.13</b>
4	<b>165-7040</b>	<b>5.70</b>	<b>5.13</b>
6	<b>165-7060</b>	<b>5.70</b>	<b>5.13</b>
8	<b>165-7080</b>	<b>5.70</b>	<b>5.13</b>
10	<b>165-7100</b>	<b>5.70</b>	<b>5.13</b>
12	<b>165-7120</b>	<b>5.70</b>	<b>5.13</b>

**Muller Tapered Square**

No.	Item#	EACH Prices	
		1-2	3+
1	<b>165-8010</b>	<b>\$5.70</b>	<b>\$5.13</b>
2	<b>165-8020</b>	<b>5.70</b>	<b>5.13</b>
3	<b>165-8030</b>	<b>5.70</b>	<b>5.13</b>

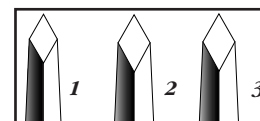
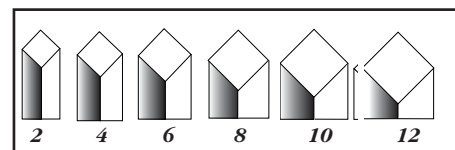
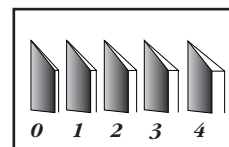
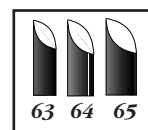
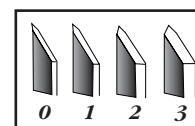
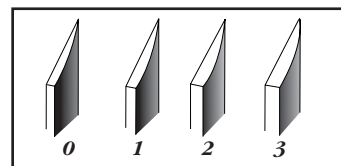
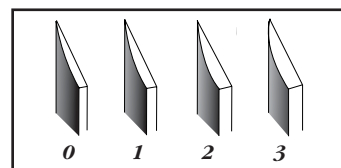





**A, B GRS® Engraver's Blocks**

The Magnablock and the Small Block are extremely well-made devices used to hold objects firmly for engraving and general-purpose work. Each holds both large and small items. Features heavy weight and adjustable drags for keeping the workpiece in the proper position. Uses two industrial ball bearings and a large roller thrust bearing to eliminate side play and wobble. Includes rubber ring pad with Nylon glides, upper jaw plates, five pins and wrench. Available with or without 30-Piece Attachment Set (see below). Made in USA.

**Features:**

- Solid steel construction for exceptional durability
- Adjustable friction lock for crown rotation control
- Nonglare satin finish on body, black oxide finish on jaws
- Precision-machined parts for smooth, efficient operation
- Infinite working angles for comfort

Specifications:	Magnablock	Small Block
Spherical Diameter	5 <sup>3</sup> / <sub>4</sub> "	5 <sup>1</sup> / <sub>8</sub> "
Jaw Size	3 <sup>1</sup> / <sub>2</sub> "W x 1 <sup>3</sup> / <sub>4</sub> "H	2 <sup>1</sup> / <sub>2</sub> "W x 1 <sup>1</sup> / <sub>2</sub> "H
Max. Jaw Opening	3 <sup>1</sup> / <sub>2</sub> "	3"
Net/Ship. Wt.	30/33 lbs.	19/22 lbs.

Description	Item#	Each
<b>A. Magnablock</b>	<b>856-0275</b>	<b>\$498.00</b>
Magnablock with 30-Piece Attachment Set	<b>856-0276</b>	<b>549.00</b>
<b>B. Small Block</b>	<b>821-6000</b>	<b>388.00</b>
Small Block with 30-Piece Attachment Set	<b>821-6005</b>	<b>448.00</b>



**C GRS® 30-Piece Attachment Set**

Includes 30 GRS block attachments and a wooden storage tray.

Description	Item#	Each
30-Piece Attachment Set	<b>856-0277</b>	<b>\$78.00</b>



**D GRS® Contoured Vise Jaw Set**

Ideal for holding irregularly shaped parts in GRS Engraver's Blocks. Fits in top holes of blocks. Rubber-lined jaws automatically conform to a part's shape to grip it firmly with minimal clamping force. Small jaw can be rotated 180° for greater versatility. Provides a fast and safe way to hold shaped mold inserts and irregular items for polishing.

Description	Item#	Each
Contoured Vise Jaw Set	<b>821-5997</b>	<b>\$59.00</b>

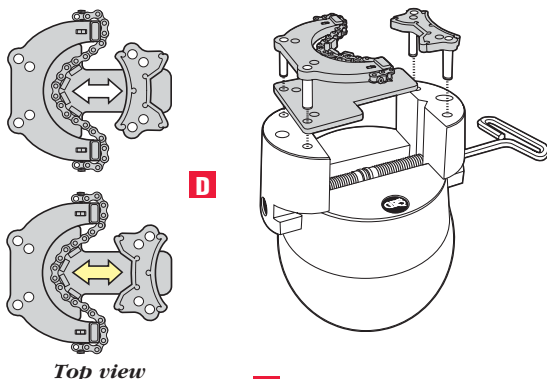

Top view

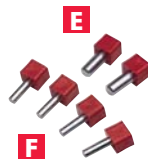

**E, F GRS® Super Pins**

Hold large parts for polishing without marring. Fit in jaw holes of GRS Engraver's Blocks. Made of heavy-duty plastic with steel shanks.

Description	Item#	Pkg. of 2
<b>E. Super Pins with 3/8" shanks</b>	<b>821-5999</b>	<b>\$4.90</b>
Description	Item#	Pkg. of 4
<b>F. Super Pins with 1/4" shanks</b>	<b>821-5998</b>	<b>\$8.40</b>

**A - F Graver Handles**

Six different hardwood handles with metal ferrules for firmly holding gravers.

Description	Style	Dia. x L	Item#	EACH Prices		
				3-9	12-141	144+
<b>A.</b> Small Half-Head	4	1 <sup>1</sup> / <sub>16</sub> " x 1 <sup>1</sup> / <sub>2</sub> "	<b>170-2040</b>	<b>\$1.35</b>	<b>\$1.15</b>	<b>\$.95</b>
<b>B.</b> Medium Half-Head	8	1 <sup>1</sup> / <sub>4</sub> " x 1 <sup>1</sup> / <sub>2</sub> "	<b>170-2080</b>	<b>1.21</b>	<b>1.03</b>	<b>.85</b>
<b>C.</b> Large Half-Head	7	1 <sup>1</sup> / <sub>4</sub> " x 1 <sup>3</sup> / <sub>4</sub> "	<b>170-2070</b>	<b>1.45</b>	<b>1.23</b>	<b>1.02</b>
<b>D.</b> X-Large Half-Head	5	1 <sup>1</sup> / <sub>4</sub> " x 2 <sup>1</sup> / <sub>4</sub> "	<b>170-2050</b>	<b>1.45</b>	<b>1.23</b>	<b>1.02</b>
<b>E.</b> Mushroom	9	1 <sup>3</sup> / <sub>8</sub> " x 1 <sup>7</sup> / <sub>8</sub> "	<b>170-2090</b>	<b>1.95</b>	<b>1.66</b>	<b>1.37</b>
<b>F.</b> Ball	11	1 <sup>3</sup> / <sub>8</sub> " x 1 <sup>5</sup> / <sub>8</sub> "	<b>170-2110</b>	<b>1.35</b>	<b>1.15</b>	<b>.95</b>

*Three-piece minimum; please order in multiples of three.*



**G - J Rosewood Graver Handles**

Four different rosewood handles with metal ferrules for firmly holding gravers.

Description	Dia. x L	Item#	Each
<b>G.</b> Small Half-Head	1 <sup>1</sup> / <sub>8</sub> " x 1 <sup>1</sup> / <sub>2</sub> "	<b>170-2140</b>	<b>\$2.25</b>
<b>H.</b> Large Half-Head	1 <sup>3</sup> / <sub>8</sub> " x 2 <sup>1</sup> / <sub>8</sub> "	<b>170-2141</b>	<b>2.25</b>
<b>I.</b> Mushroom	1 <sup>1</sup> / <sub>4</sub> " x 2"	<b>170-2143</b>	<b>2.25</b>
<b>J.</b> Ball	1 <sup>3</sup> / <sub>8</sub> " x 1 <sup>3</sup> / <sub>4</sub> "	<b>170-2142</b>	<b>2.25</b>



**K GRS® Thermo-Loc Handle™ Set**

Eliminates need for drilling handles, helping end frustration. Includes four color-coded round graver handles (rosewood, honey beige, pewter and dusk) with Thermo-Loc cores. Easy to use: microwave handle in water for 1–2 minutes or heat graver tang, then insert graver in handle. Just warm handle to remove graver and insert another. Handles measure 1<sup>5</sup>/<sub>16</sub>" dia. x 1<sup>1</sup>/<sub>2</sub>L.

Description	Item#	Each
Thermo-Loc Handle Set	<b>170-2145</b>	<b>\$8.95</b>



**L GRS® Adjustable Graver Handle Set**

Includes three adjustable aluminum handles that are color-coded for easy graver identification. To adjust, just loosen lock screw, slide graver to desired position and tighten.

Description	Item#	Each
Adjustable Graver Handle Set	<b>170-2201</b>	<b>\$28.95</b>



**M Graver Handle with Tool Chucks**

Wooden handle with two interchangeable tool chucks for holding gravers and other small tools up to 3mm. To swap tools, just unscrew knurled holder, remove chuck, replace with other chuck and screw holder back on. Graver not included.

Description	Item#	Each
Graver Handle with Tool Chucks	<b>840-4210</b>	<b>\$8.59</b>





## A, B GRS® Power Hone Dual-Angle Sharpening System

Sharpens gravers and tools in seconds without heat. Provides sharper, stronger tool edges for making brighter cuts. Teaches the beginner proper sharpening in minutes. Saves the professional an hour or more each day by drastically reducing time spent sharpening and resharpening.

First uses diamond wheels to sharpen hardened steel, high-speed steel and carbide tools and gravers, then uses ceramic lap with diamond spray to impart a high final polish. Lets you choose the best tool material for each job because it can sharpen them all. Features rugged steel housing, continuous-duty motor and double-bearing spindle for years of dependability. Remarkably easy to use.

System includes Power Hone, Dual-Angle Sharpening Fixture, Quick-Change Wheel Adapter, two Diamond Wheels (260 grit and 600 grit), Ceramic Lap, Diamond Spray and Wheel Storage Rack. Made in USA.



Description	Item#	Each
A. Power Hone Dual-Angle Sharpening System, 110V*	<b>856-0295</b>	<b>\$858.00</b>
Power Hone w/600 grit Diamond Wheel only, 110V	<b>856-0255</b>	<b>379.00</b>
B. Dual-Angle Sharpening Fixture, head only	<b>856-0299</b>	<b>179.00</b>



## C GRS® Power Hone Graver Sharpening Fixture

Takes the guesswork out of sharpening gravers and speeds up the sharpening process. Allows the operator to dial in precise cutting angles on its large calibrated dial. Both the face and the heel of the graver can be cut to the necessary working angles by flipping the tool and dialing in the individual angles. The base is magnetized to sit securely on top of the Power Hone. Simple to operate—even a beginner can make a perfectly angled cut every time.

Description	Item#	Each
Graver Sharpening Fixture	<b>856-0200</b>	<b>\$92.00</b>

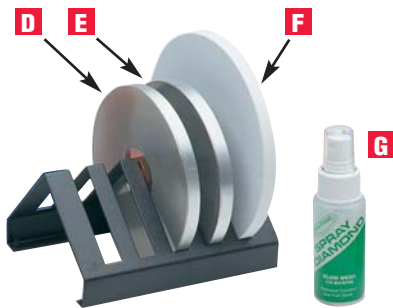

## D - G GRS® Power Hone Wheels

The low-cost, high-quality Diamond Wheels minimize heat buildup in gravers and tools, last for years and stay flat for accuracy. Produce a fine, dependable finish. Excellent for sharpening carbide, cobalt and standard steel tools. Available in three grits. Measure 5" dia. x 1/2" AH. The solid Ceramic Lap produces a mirror finish on gravers and tools, resulting in beautiful, bright cuts on your workpieces. Measures 6" dia. x 1/2" AH. Must be periodically charged with Diamond Spray Compound (sold in a 2 fl. oz. bottle containing 1 ct. diamond). Can be used with Quick-Change Wheel Conversion Set (see below).

Description	Item#	Each
D. 600 Grit Diamond Wheel	<b>856-0256</b>	<b>\$89.00</b>
E. 1200 Grit Diamond Wheel	<b>856-0032</b>	<b>114.00</b>
F. Ceramic Lap	<b>856-0258</b>	<b>188.60</b>
G. Diamond Spray Compound, 2 fl. oz.	<b>856-0260</b>	<b>23.90</b>



## H GRS® Power Hone Quick-Change Wheel Conversion Set

Easily attaches to the Power Hone without tools. Lets you change wheels in seconds: simply lift wheel off and replace with another. Can be used with all GRS 5" and 6" wheels.

Description	Item#	Each
Power Hone Wheel Conversion Set	<b>856-0261</b>	<b>\$49.00</b>

**A Crocker-Style Graver Sharpening Fixture**

Keeps graver in a fixed position for sharpening on a bench stone (see pp. 25, 29 and 30 for bench stones). Holds graver at any angle: just set index and lock in for repeated accuracy. Stone and graver not included.

Description	Item#	Each
Crocker-Style Graver Sharpening Fixture	<b>816-1000</b>	<b>\$42.00</b>

**B Graver Sharpening Holder**

A small, inexpensive holder for use during sharpening on a bench stone (see pp. 25, 29 and 30 for bench stones). Holds graver in either of two angled openings. Roller on bottom facilitates sharpening. Measures 1 3/8"W x 1 1/2"H.

Description	Item#	Each
Holder for Graver Sharpening	<b>816-1012</b>	<b>\$6.95</b>

**C Die Sinker's High-Speed Steel Chisels**

Made of the finest grade high-speed steel. Feature one-piece construction ground to shape from round stock. Excellent for removing large amounts of material uniformly. Will not lose temper when ground or sharpened. Measure 6" long. Sold individually and in a set of all 12 styles.

Description	Item#	EACH Prices	
		1-11	12+
Chisel #1	<b>166-9010</b>	<b>\$13.50</b>	<b>\$11.25</b>
Chisel #2	<b>166-9020</b>	<b>13.50</b>	<b>11.25</b>
Chisel #3	<b>166-9030</b>	<b>13.50</b>	<b>11.25</b>
Chisel #4	<b>166-9040</b>	<b>13.50</b>	<b>11.25</b>
Chisel #5	<b>166-9050</b>	<b>13.50</b>	<b>11.25</b>
Chisel #6	<b>166-9060</b>	<b>13.50</b>	<b>11.25</b>
Chisel #7	<b>166-9070</b>	<b>13.50</b>	<b>11.25</b>
Chisel #8	<b>166-9080</b>	<b>13.50</b>	<b>11.25</b>
Chisel #9	<b>166-9090</b>	<b>13.50</b>	<b>11.25</b>
Chisel #10	<b>166-9100</b>	<b>13.50</b>	<b>11.25</b>
Chisel #11	<b>166-9110</b>	<b>13.50</b>	<b>11.25</b>
Chisel #12	<b>166-9120</b>	<b>13.50</b>	<b>11.25</b>
12-Piece Set	<b>166-9990</b>	<b>145.00</b>	<b>-</b>

**D Diamond Scriber**

Features diamond point set in nonroll hexagonal handle. Will mark any metal. Measures 5 1/4" long.

Description	Item#	EACH Prices	
		1-2	3+
Diamond Scriber	<b>220-1900</b>	<b>\$9.97</b>	<b>\$8.97</b>

**E Carbide-Tipped Scriber**

Can be used on hardest metals, glass and more. Slim design is comfortable to use. Hexagonal aluminum handle prevents rolling. Measures 5 1/4" long.

Description	Item#	EACH Prices	
		1-2	3+
Carbide Tipped Scriber	<b>816-0950</b>	<b>\$4.40</b>	<b>\$3.96</b>

**F Steel Needle Scriber**

One-piece steel scriber with knurled handle. Measures 4 1/2" long.

Description	Item#	EACH Prices	
		1-2	3+
Steel Needle Scriber	<b>816-0905</b>	<b>\$1.85</b>	<b>\$1.67</b>

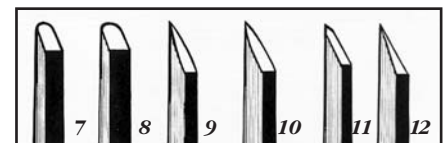
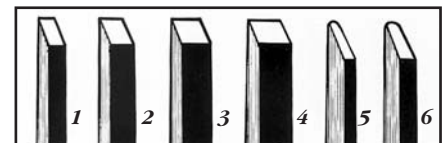
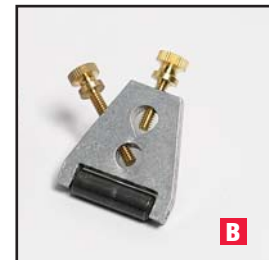





## A, B Ceramic Plastic Deflashing Tools

Each holds edge indefinitely and provides complete user safety.

These tools feature space-age ceramics that deburr hard plastics effortlessly while eliminating the fear of cutting your hands or fingers in the process. Ideal for curved and complicated shapes. Excellent on ultra-hard resins that defy carbon steel tools. Can also be used on soft metals such as aluminum, copper and brass. Available in two disposable sizes: large deflasher (6<sup>7</sup>/<sub>8</sub>" long with 1<sup>1</sup>/<sub>2</sub>" long cutting edge) has matte cutter-type handles; small deflasher (5<sup>1</sup>/<sub>4</sub>" long with 1" long cutting edge) has a fluted, nonroll design.

Description	Item#	Each
A. Large Ceramic Deflasher	<b>351-0295</b>	<b>\$32.95</b>
B. Small Ceramic Deflasher	<b>351-0294</b>	<b>29.95</b>



## C All-in-One Swiveling Deburrer – With five tips

Deburs holes as small as <sup>3</sup>/<sub>32</sub>" and removes sharp or rough edges from steel, aluminum, brass or iron parts. Comes with five curved, sharpened, high-speed steel tips made from <sup>1</sup>/<sub>8</sub>" stock for long wear and less chance of breakage. Each tip swivels 360° either way to follow curves and contours. Handle has an internal storage compartment and a quick-tip-release feature. Measures 5" long.

Description	Item#	Each
All-in-One Swiveling Deburrer	<b>846-2050</b>	<b>\$15.90</b>



## D Swiveling Deburrer – With two tips

Makes quick work of radiusing and rounding off corners and edges. Comes with two curved, sharpened, hardened tool steel tips to quickly deburr soft metals: one large (approx. 3mm diameter) and one small (approx. 2mm diameter). Each tip swivels 360° either way to follow curves and contours. Hexagonal metal handle will not roll. Measures <sup>1</sup>/<sub>2</sub>" dia. x 5<sup>7</sup>/<sub>8</sub>"L.

Description	Item#	Each
Swiveling Deburrer	<b>846-2055</b>	<b>\$12.65</b>



## E Improved Adjustable Scraper

Three-square double-ended blade mounted in a knurled handle. Blade slips fully inside handle when not in use for maximum safety and longevity. Blade and handle measure 3<sup>1</sup>/<sub>2</sub>" long.

Description	Item#	Each
Improved Adjustable Scraper	<b>816-0130</b>	<b>\$31.30</b>



## F, G Wooden Handle Scrapers

Lightweight tools excellent for cleaning, smoothing and deburring metals and plastics. Use to prepare surfaces for soldering and to remove excess solder and scale. Three-square chrome alloy steel blades are sharp their entire length and can be resharpened on a bench stone (see pp. 25, 29 and 30 for bench stones). Each 2<sup>1</sup>/<sub>2</sub>" long blade is securely mounted in a 3<sup>7</sup>/<sub>8</sub>" long hollow or solid hardwood handle.

Blade	Item#	Each
F. Hollow	<b>816-0150</b>	<b>\$7.25</b>
G. Solid	<b>816-0160</b>	<b>9.00</b>



**A - C Plastic Knife Handles**

Plastic handles contoured to fit your hand. Hold blades securely. Measure 4½" long. BP-6 accepts only Heavy-Duty Steel Knife Blade #260-3000 (see below).

Description	Item#	Each
A. BP-5 USA	<b>260-3050</b>	<b>\$15.85</b>
B. BP-6 USA	<b>260-3051</b>	<b>15.95</b>
C. Imported	<b>260-3052</b>	<b>5.30</b>



**A**



**B**



**C**

**D Stainless Steel Knife Handle**

Smooth, durable stainless steel handle. Holds blades securely. Measures 4⅞" long.

Description	Item#	EACH Prices	
		1-5	6+
Stainless Steel Knife Handle	<b>260-3055</b>	<b>\$3.10</b>	<b>\$2.79</b>



**D**

**E - G Swann Morton® Knife Blades**

High-carbon steel surgical blades (nonsterilized) for precise cutting. Last much longer and are sharper than stainless steel blades. Available in packages of five blades or individually wrapped boxes of 100. Fit plastic and stainless steel handles shown above except #260-3051.

Description	Item#	Pkg. of 5	Item#	BOX of 100		
				1-4	5-14	15+
E. #11 Straight	<b>260-2951</b>	<b>\$1.75</b>	<b>260-2952</b>	<b>\$21.50</b>	<b>\$20.43</b>	<b>\$19.35</b>
F. #12 Curved	<b>260-3001</b>	<b>1.75</b>	<b>260-3002</b>	<b>21.50</b>	<b>20.43</b>	<b>19.35</b>
G. #10A Wide-Angle Straight	-	-	<b>260-3005</b>	<b>21.50</b>	<b>20.00</b>	<b>19.35</b>



**E**



**F**



**G**

**H Heavy-Duty Steel Knife Blade**

Features exclusive rib-back design for added strength. Fits only Plastic Knife Handle #260-3051 (see above).

Description	Item#	BOX of 150		
		1-4	5-14	15+
#25 Heavy-Duty Blade	<b>260-3000</b>	<b>\$99.00</b>	<b>\$92.07</b>	<b>\$89.10</b>



**H**

**I, J Soft Grip Knife**

Round knife with comfortable nonslip, soft grip handle. Blades are held securely and locked or released by turning knurled knob at end of handle. Comes with one #11 blade. Measures 4¾" long without blade. Color: blue.

Description	Item#	Each
I. Soft Grip with #11 Blade	<b>260-3040</b>	<b>\$3.35</b>
J. Optional #16 Steel Blades, pkg. of five	<b>260-3048</b>	<b>1.15</b>
Replacement #11 Steel Blades, pkg. of five	260-3045	1.35



**I**



**J**

**K Bench Knife**

An all-purpose bench knife for scraping and cutting. Consists of steel blade mounted in a hardwood handle. Measures 5¼" long with 1¾" long blade.

Description	Item#	Each
Bench Knife	<b>260-3059</b>	<b>\$3.60</b>



**K**



**TolTec Microimage Measurer used with wire cutter**

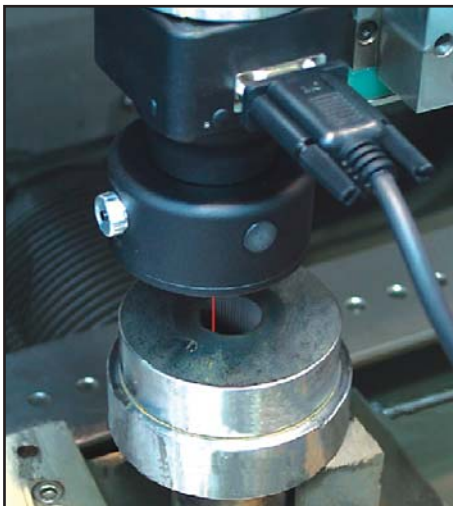

**TolTec Lens using laser point finder**



## A - D TolTec® Microimage Measurer

The TolTec Microimage Measurer verifies the accuracy of mold measurements during the mold making process while the mold is still in place on the EDM or milling machine, helping boost your productivity. Eliminates the time-consuming, error-prone routine of having to remove, measure and relocate the mold, allowing you to check tolerances on the fly with ease. Minimizes costly mistakes often caused by inexact mold repositioning. Accurate measurements are taken and recorded from the machine's CNC controller. See below for available systems and components.

### Features:

- Precise, in-process measurement verification without removing mold from host machine for reduced downtime and increased productivity
- Quick, hassle-free changeover from tooling head to imaging head
- In-process X-Y tolerance verification
- High-resolution video inspection with 15" LCD monitor and laser point finder
- Working tolerances equal to those of host machines
- Compatibility with a variety of different EDM and milling machines
- Choice of 30X, 55X and 250X lenses and 3R, EROWA and NB fixtures

System with Monitor	Lens + Fixture	Item#	Each
<b>A.</b> TTC30LS-3R	30X + 3R	<b>511-1000</b>	<b>\$6,695.00</b>
TTC55LS-3R	55X + 3R	<b>511-1005</b>	<b>6,995.00</b>
TTC250LS-3R	250X + 3R	<b>511-1010</b>	<b>8,295.00</b>
TTC30LS-ER	30X + EROWA	<b>511-1015</b>	<b>6,695.00</b>
TTC55LS-ER	55X + EROWA	<b>511-1020</b>	<b>6,995.00</b>
TTC250LS-ER	250X + EROWA	<b>511-1025</b>	<b>8,295.00</b>
TTC30LS-NB 12mm	30X + NB 12mm	<b>511-1030</b>	<b>6,695.00</b>
TTC55LS-NB 12mm	55X + NB 12mm	<b>511-1045</b>	<b>6,995.00</b>
TTC250LS-NB 12mm	250X + NB 12mm	<b>511-1060</b>	<b>8,295.00</b>
TTC30LS-NB 16mm	30X + NB 16mm	<b>511-1035</b>	<b>6,695.00</b>
TTC55LS-NB 16mm	55X + NB 16mm	<b>511-1050</b>	<b>6,995.00</b>
TTC250LS-NB 16mm	250X + NB 16mm	<b>511-1065</b>	<b>8,295.00</b>
TTC30LS-NB 20mm	30X + NB 20mm	<b>511-1040</b>	<b>6,695.00</b>
TTC55LS-NB 20mm	55X + NB 20mm	<b>511-1055</b>	<b>6,995.00</b>
TTC250LS-NB 20mm	250X + NB 20mm	<b>511-1070</b>	<b>8,295.00</b>
Lens + Fixture Only		Item#	Each
<b>B.</b> 30X + 3R		<b>511-1002</b>	<b>\$4,395.00</b>
55X + 3R		<b>511-1007</b>	<b>4,695.00</b>
250X + 3R		<b>511-1012</b>	<b>5,995.00</b>
<b>C.</b> 30X + EROWA		<b>511-1017</b>	<b>4,395.00</b>
55X + EROWA		<b>511-1022</b>	<b>4,695.00</b>
250X + EROWA		<b>511-1027</b>	<b>5,995.00</b>
<b>D.</b> 30X + NB 12mm		<b>511-1032</b>	<b>4,395.00</b>
55X + NB 12mm		<b>511-1047</b>	<b>4,695.00</b>
250X + NB 12mm		<b>511-1062</b>	<b>5,995.00</b>
30X + NB 16mm		<b>511-1037</b>	<b>4,395.00</b>
55X + NB 16mm		<b>511-1052</b>	<b>4,695.00</b>
250X + NB 16mm		<b>511-1067</b>	<b>5,995.00</b>
30X + NB 20mm		<b>511-1042</b>	<b>4,395.00</b>
55X + NB 20mm		<b>511-1057</b>	<b>4,695.00</b>
250X + NB 20mm		<b>511-1072</b>	<b>5,995.00</b>
Monitor Only		Item#	Each
15" LCD		<b>511-1075</b>	<b>\$2,415.00</b>

## Mantis® Stereo Optical Inspection System

The accepted standard of ergonomic wide-field inspection for quality control, redesigned to incorporate the most modern technological advances in optical design, plastic molding and LED illumination. Choose from two distinct versions: the affordable Compact and the high-performance Elite.

Each one combines the viewing ease of a bench magnifier with the high resolution of a microscope. Provides a large viewing area that promotes maximum user comfort while producing razor-sharp 3-D stereo images. Eliminates the muscle fatigue and eyestrain commonly associated with traditional eyepiece technologies. Easily accommodates users who wear safety or prescription glasses.

### Mantis Compact or Mantis Elite?

Mantis Compact is smaller, with lower magnification (4X and 6X) and a considerably lower price. Mantis Elite offers high-performance enhancements, including powerful magnification (up to 20X) and an extra-large field of view. The Elite head can be tilted from +5° to -20° for added viewing adjustment and compensation for taller subjects. Includes a twin turret that holds two lenses simultaneously, allowing the user to rotate either lens into place as needed, as well as an ambient glare shield.

Both Compact and Elite can be mounted on a counterbalanced universal stand that allows fluid movement and stop-on-a-dime positioning or on a stable bench stand that offers integrated focus and dimmable substage illumination. Please specify stand type and lens power(s) when ordering.

Optional Floating Stage for Compact and Elite bench stands features multidirectional capability, making it very easy to position items in the viewing field.

### Compact and Elite Features:

- Stereo viewing with true optical magnification (neither diopter nor video)
- Patented expanded-exit pupil technology for free head movement and eye comfort
- Multilayer anti-reflection coated optics
- Adjustable interpupillary distance (59–76mm)
- Choice of counterbalanced universal stand or bench stand
- Bright white LED illumination, true daylight color-corrected
- Noiseless, cool operation

### Specifications:

	Mantis Compact	Mantis Elite
Available Lenses	4 / 6X	4 / 6 / 8 / 10 / 15 / 20X
Working Distance	96 / 73mm	96 / 68 / 59 / 54 / 40 / 29mm
Field of View	27.5 / 19.2mm	34 / 23 / 17 / 13.5 / 8.8 / 6.5mm
Illumination	Twin-bank 20-LED array	Two-piece, twin-bank 24-LED array
Electrical	110/220V (universal)	110/220V (universal)
Dimensions		
Head Width	213mm	213mm
Height Range*	395–605mm	415–624mm
Depth Range*	565–775mm	593–802mm

\*On Universal Stand.

Description	Mantis Compact*		Mantis Elite*	
	Item#	Each	Item#	Each
Head	<b>271-3040</b>	<b>\$950.00</b>	<b>271-3030</b>	<b>\$1,475.00</b>
Universal Stand	<b>271-3041</b>	<b>525.00</b>	<b>271-3031</b>	<b>635.00</b>
Bench Stand	<b>271-3042</b>	<b>1,035.00</b>	<b>271-3032</b>	<b>1,120.00</b>
Optional Floating Stage	<b>271-3050</b>	<b>620.00</b>	<b>271-3050</b>	<b>620.00</b>
4X Lens	<b>271-3043</b>	<b>110.00</b>	<b>271-3033</b>	<b>150.00</b>
6X Lens	<b>271-3044</b>	<b>190.00</b>	<b>271-3034</b>	<b>325.00</b>
8X Lens	–	–	<b>271-3035</b>	<b>515.00</b>
10X Lens	–	–	<b>271-3036</b>	<b>565.00</b>
15X Lens	–	–	<b>271-3037</b>	<b>650.00</b>
20X Lens	–	–	<b>271-3038</b>	<b>675.00</b>
4, 6X Lens Cap	<b>271-3051</b>	<b>18.65</b>	–	–
4, 8, 10X Lens Cap	–	–	<b>271-3052</b>	<b>25.00</b>
6X Lens Cap	–	–	<b>271-3053</b>	<b>21.30</b>

\*Compact and Elite components are not interchangeable.



Compact Head and Universal Stand\*

Compact Head and Bench Stand\*

\*Head, stand and lenses sold separately.



Elite Head and Bench Stand\*

Elite Head and Universal Stand\*

\*Head, stand and lenses sold separately.



Long working distance and extra-large field of view make working under magnification easy.



Precision Mantis lenses offer superior optics.



**A Meiji Stereo Zoom Microscopes**  
**Standard Binocular and Camera-Ready Trinocular Styles**



**A**

From the premier optics manufacturer in Japan, these microscopes feature a Greenough optical design and high-resolution optics free of chromatic and spherical aberrations for yielding crystal-clear upright and unreversed stereoscopic images with rich contrast, impressive brightness and true-to-life color. Boast great depth of field and image flatness for accurate viewing and long working distances for ample workspace. Ideal for inspection of fine details.

Lightweight yet durable all-metal aluminum alloy bodies with premium components and chemical-resistant finishes provide stability and durability for a lifetime of dependable use. The 45°-inclined observation tubes with adjustable interpupillary distance and diopter tubes eliminate eyestrain.

Acrobat Boom Stand with friction arms, focus block and padded headrest ensures superb flexibility and comfort. Entire assembly can be easily positioned and quickly swung away when not in use. Friction arms lock in place when needed. Focus block securely holds microscope body. Padded headrest reduces neck and back fatigue.

Ring Light with extra-bright circular fluorescent bulb provides cool, glare-free illumination. Fits many other microscopes besides those from Meiji. Electrical: 115V.

**Features:**

- Binocular and Trinocular styles that can be rotated 360° and locked in any position
- High-resolution optics for yielding upright and unreversed stereoscopic images
- Rugged all-metal bodies and components designed to last a lifetime
- Ergonomically positioned bilateral zoom controls
- Interpupillary distance adjustment from 54–75mm
- Dual dioptic adjustment (±5 diopters) for maintaining focus throughout zoom range

**Binocular/Trinocular Components:**

- 10X eyepieces with eyeshields
- 0.5X auxiliary objective lens for increased working distance
- GRS Acrobat Boom Stand with focus block and headrest
- Ring Light, 115V
- Protective dust cover
- Instruction manual



*Ring Light*



*Ring Light Circuline Bulb*

**Specifications:**

Body Style	Binocular or Trinocular, each with 360° rotation
Zoom Control	Dual, graduated, bilateral mount
Zoom Range	0.7–4.5X (0.35–2.25X with 0.5X objective lens)
Magnification	7–45X (3.5–22.5X with 0.5X objective lens)
Field of View	32.8–5.1mm (65.6–10.2mm with 0.5X objective lens)
Working Distance	93mm (Binocular/Trinocular with 0.5X objective lens: 150/170mm)
Interpupillary Distance	Adjustable from 54–75mm
Dioptic Adjustment	Dual (±5 diopters)

Description	Item#	Each
A. Binocular Microscope with Acrobat Stand and Ring Light	<b>271-3029</b>	<b>\$1,830.00</b>
Trinocular Microscope with Acrobat Stand and Ring Light*	<b>271-3067</b>	<b>2,375.00</b>

*\*Designed for photo and video applications. When the beamsplitter is engaged, it does not obstruct the eyetubes; all three view ports are lighted for simultaneous use. Can be used with most cameras, including digital, SLR, digital SLR and CCD. Call for available adapters.*

**B GRS® Positioning Vise for Stereo Zoom Microscopes**

Simply pull a lever, and this vise lets you easily reposition its center of rotation to keep the object within your microscope's field of view. Its upper half moves off-center to left or right as desired; after moving, it rotates about set position. Includes upper jaw plates, five pins and wrench. Spherical diameter: 7.1". Jaw size: 3"W x 1.8"H. Max. jaw opening: 3.5". Weighs a massive 42 lbs. for incredible stability.

**B**



Description	Item#	Each
Positioning Vise for Stereo Zoom Microscopes	<b>271-3025</b>	<b>\$748.00</b>

**A Stereo Zoom Microscopes**

**Standard Binocular and Camera-Ready Trinocular Styles**

Professional zoom microscopes mounted on freestanding booms. Ideal for inspection of fine details. Choose from standard binocular and camera-ready trinocular styles. Both units offer excellent optics and true stereo imaging, 4X stepless zoom, 5–160X magnification and ring light with on/off switch for maximum illumination. Electrical: 110V.

Use 1½" diameter boom to extend microscope head securely up to approx. 24" with absolutely no wobble, then use smaller boom with fine adjustment knob to extend head up to 2" more while remaining seated. Head can also be infinitely positioned from 0–90° and moved up and down riser to a minimum height of 18" from the tabletop. Weighted 10" square base ensures stability. All parts are precision-machined for smooth-glide action.

**Specifications:**

Zoom Range	1–4X
Eyepieces	10X and 20X
Objective Lenses	0.5X and 2X
Magnification	5–160X (5X = 1X Zoom x 10X Eyepiece x 0.5X Objective; 160X = 4X Zoom x 20X Eyepiece x 2X Objective)
Field of View	20mm and 13mm
Working Distance	160mm and 30mm
Focus Adjustment Range	50mm

Description	Item#	Each
<b>A. Binocular Microscope with Ring Light</b>	<b>810-0065</b>	<b>\$1,785.00</b>
<b>B. Trinocular Microscope with Ring Light*</b>	<b>810-0066</b>	<b>1,995.00</b>
Replacement Lightbulb	810-0067	19.60

*\*Designed for photo and video applications. When the beamsplitter is engaged, it does not obstruct the eyetubes; all three view ports are lighted for simultaneous use. Can be used with most cameras, including digital, SLR, digital SLR and CCD. Call for available adapters.*

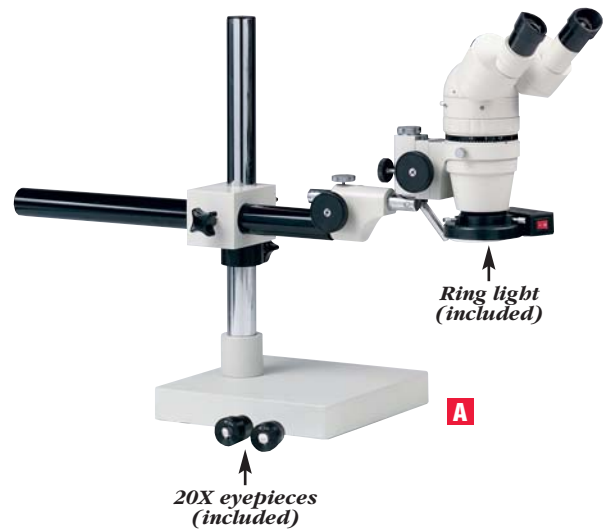

**C Eschenbach MaxDetail**

From Eschenbach, the premier magnification specialists, this lightweight headset offers high-end features at an affordable price. Galilean design allows magnification and focus to be adjusted independently for each lens, providing outstanding clarity for each eye. Magnifies objects 2X (comparable to a DA-4 Optivisor). Includes sturdy zippered protective case and head strap.

**Features:**

- Galilean design provides wide field of view (20°) and independently adjustable magnification and focus for each lens.
- Individually focusable objective lenses compensate for ±3-diopter spherical correction or allow adjustment for close-up activities.
- Lightweight PXM(R) optics and flexible plastic temples (1.7 oz.) and smooth molded bridge ensure comfortable extended wear.
- Frosted objective housing eliminates distracting reflections.

Description	Item#	Each
Eschenbach MaxDetail	<b>272-3280</b>	<b>\$79.90</b>







**A Bausch & Lomb® Magna Visor with Three Lenses**

This lightweight and well-balanced magnifying visor can be worn comfortably for long periods of time. Features contemporary formfitting design with extra-thick padded band and adjusting hardware to prevent loosening and slipping. Flips up when not in use. Includes three high-quality optical lens plates: 1.8X, 2.2X and 2.6X, with focal distances of 12", 8" and 6", respectively. Lens plates can be quickly removed and cleaned without tools. For easy, thorough cleaning of lens plates, use B&L Cleaning Tissues #272-1001 (see p. 264).

Description	Item#	Each
Magna Visor with Three Lenses	<b>272-3103</b>	<b>\$35.95</b>



**B Optivisor®**

All Optivisor binocular lens plates are made of high-quality optical glass, ground and polished to precision ophthalmic standards. Each lens plate comes mounted in a lightweight, durable, impact-resistant visor assembly, available in blue or black. Includes a genuine leather adjustable headband for comfortable all-day wear (adjust by turning knurled knob at the rear). The visor also has an adjustable pivot assembly to keep it in desired position. All Optivisor lens plates are interchangeable.

Style	Power	Focal Distance	Blue Item#	Black Item#	Each
DA-2	1½X	20"	<b>270-1020</b>	<b>270-1120</b>	<b>\$28.40</b>
DA-3	1¾X	14"	<b>270-1030</b>	<b>270-1130</b>	<b>28.40</b>
DA-4	2X	10"	<b>270-1040</b>	<b>270-1140</b>	<b>28.40</b>
DA-5	2½X	8"	<b>270-1050</b>	<b>270-1150</b>	<b>28.40</b>
DA-7	2¾X	6"	<b>270-1070</b>	<b>270-1170</b>	<b>29.00</b>
DA-10	3½X	4"	<b>270-1100</b>	<b>270-1180</b>	<b>29.00</b>
Replacement Lens			Item#	Each	
DA-2			270-2020	\$20.90	
DA-3			270-2030	20.90	
DA-4			270-2040	20.90	
DA-5			270-2050	20.90	
DA-7			270-2070	21.75	
DA-10			270-2100	21.75	
Replacement Headband Assemblies			Item#	Each	
Blue (without lens)			270-1010	\$18.15	
Black (without lens)			270-1115	18.15	



Flips up when not in use.



**C Optivisor® Optiloupe**

Attach to Optivisor (see above) for additional 2½X magnification power for one eye.

Description	Item#	Each
Optivisor Optiloupe	<b>270-2200</b>	<b>\$8.75</b>



**D Optivisor® Light**

Clip this lightweight battery-powered light onto Optivisor (see above) to illuminate the magnified viewing area. Features 6000-candlepower xenon bulb. Swivels up and down for optimal light coverage. Available in two styles: LT-06 with 10" cord, for mounting battery pack directly on headband; and LT-42 with 42" cord, for placing battery pack on a belt or in a pocket. Operates on two AA batteries (not included). Allows 4–5 hours of continuous use.

Style	Item#	Each
LT-06	<b>270-2150</b>	<b>\$19.95</b>
LT-42	<b>270-2151</b>	<b>19.95</b>

**D** Optivisor sold separately.

**A Mark 2 Magni-Focuser®**

Lightweight, binocular magnifiers with interchangeable lens units. These magnifiers offer clear, comfortable vision. The comfort design headband has dial adjustment for exact fit. Lens is shatter-resistant, optical-quality acrylic. Measures 3 1/8"L x 1 1/8"H. Auxiliary lens provides additional 2 1/2X magnification for one eye.

Style	Power	Focal Distance	Item#	EACH Prices		Replacement Lens Item#	Each
				1-2	3+		
103	1 3/4X	14"	<b>271-1030</b>	<b>\$20.50</b>	<b>\$17.08</b>	271-2030	\$10.50
105	2 1/4X	8"	<b>271-1050</b>	<b>20.50</b>	<b>17.08</b>	271-2050	10.50
107	2 3/4X	6"	<b>271-1070</b>	<b>20.50</b>	<b>17.08</b>	271-2070	10.50
110	3 1/2X	4"	<b>271-1100</b>	<b>21.50</b>	<b>17.92</b>	271-2090	13.25
113*	1 3/4X & 4 1/4X	14", 4"	<b>271-1130</b>	<b>24.75</b>	<b>20.62</b>	271-2110	16.50
115*	2 1/4X & 4 3/4X	8", 3"	<b>271-1150</b>	<b>24.75</b>	<b>20.62</b>	271-2130	16.50
117*	2 3/4X & 5 1/4X	6", 2"	<b>271-1170</b>	<b>24.75</b>	<b>20.62</b>	271-2150	16.50

\*Includes auxiliary lens.



**B Telesights®**

For use without prescription glasses. Binocular eye loupe mounted in glass lens half-frames, no heavier than ordinary eyeglasses. The half-frames stay in place. Just lower Telesights for magnification and flip up when finished. Lens is optical-quality injection-molded acrylic treated with abrasion-resistant coating.

Power	Focal Distance*	Item#	EACH Prices	
			1-2	3+
1 3/4X	13 1/2"	<b>270-0430</b>	<b>\$31.63</b>	<b>\$26.36</b>
2X	10"	<b>270-0440</b>	<b>31.63</b>	<b>26.36</b>
2 1/4X	8"	<b>270-0450</b>	<b>31.63</b>	<b>26.36</b>
2 1/2X	6 2/3"	<b>270-0460</b>	<b>31.63</b>	<b>26.36</b>
3X	5"	<b>270-0480</b>	<b>33.97</b>	<b>28.31</b>

\*Focal distance measured from eye.



**C Clip-On Binocular Magnifier with Half-Frame**

Ideal for small tasks that require hands to be free. Comes with half-frame as shown so you can use as a stand-alone magnifier. Use small clip shown when you want to clip magnifier onto your eyeglasses. Pivots up when not in use. Lightweight with dual-lens system designed to ease eyestrain by converging on focal point.

Style	Power	Focal Distance	Item#	Each
CO4	2X	10"	<b>271-1201</b>	<b>20.15</b>
CO5	2 1/2X	8"	<b>271-1202</b>	<b>20.15</b>
CO7	2 3/4X	6"	<b>271-1203</b>	<b>20.15</b>



**D Clip-On Telesights®**

For use with prescription glasses, including bifocals. The lens is optical-quality injection-molded acrylic treated with abrasion-resistant coating. Tension clamps permit instant attachment and release. Simply flip up when not in use.

Power	Focal Distance*	Item#	EACH Prices	
			1-2	3+
1 3/4X	13 1/2"	<b>270-0530</b>	<b>\$26.75</b>	<b>\$22.29</b>
2X	10"	<b>270-0540</b>	<b>26.75</b>	<b>22.29</b>
2 1/4X	8"	<b>270-0550</b>	<b>26.75</b>	<b>22.29</b>
2 1/2X	6 2/3"	<b>270-0560</b>	<b>26.75</b>	<b>22.29</b>
3X	5"	<b>270-0580</b>	<b>29.85</b>	<b>24.87</b>

\*Focal distance measured from eye.





**A Bausch & Lomb® Engraver's Magnifier**

**Great asset to mold and die polishers.**

A double-lens magnifier originally designed for the exacting work of hand tooling photo-engraved printing plates. It has near-universal application in precision work. The magnifier, in which two plano-convex lenses are used, provides the "corrected" wide, flat field.

Power	Focal Distance	Lens Diameter	Item#	Each
3½X	3"	15.9 mm	<b>272-5015</b>	<b>\$34.50</b>



**B, C Bausch & Lomb® Folding Pocket Magnifiers**

Multiple lenses can be used singly or in combination. Mounted in tough, durable black plastic frame, lenses fold into protective case. Focal distance from ½" to 3½" depending on magnification. All lenses are made of optical glass.

	No. of Lenses	Lens Powers	Magnifying Powers	Lens Diameter	Item#	EACH Prices	
						1-2	3+
<b>B.</b>	2	3X, 4X	3X, 4X, 7X	36mm	<b>272-4020</b>	<b>\$19.95</b>	<b>\$16.62</b>
<b>C.</b>	3	5X, 7X, 9X	5X, 7X, 9X, 12X, 14X, 16X, 21X	21mm 17mm	<b>272-4025</b>	<b>24.10</b>	<b>20.08</b>



**D Bausch & Lomb® Aspheric Round Magnifier**

Lightweight handheld magnifier with excellent balance for easy use. Aspheric lens provides wide field of view at higher power than a normal lens. Edge-to-edge clarity makes this magnifier ideal for large areas. Measures 6¾" long. Complete with soft protective case.

Power	Focal Distance	Lens Diameter	Item#	Each
5X	2"	50mm	<b>272-5005</b>	<b>\$27.50</b>



**E Bausch & Lomb® Illuminated Coddington Loupe**

Very useful for seeing into tight areas of a mold or die. A magnifier and light source in one. Illuminates the object being viewed through the lens. A flashlight bulb (included) is inserted into the groove of the Coddington lens. Uses two AA penlight batteries (not included). Approximately 60% of lens diameter is usable. Measures 5¾" long.

Power	Focal Distance	Lens Diameter	Item#	Each
10X	1"	19.75mm	<b>272-2037</b>	<b>\$27.50</b>



**F Linen Tester**

Although the name is derived from the textile industry, this loupe can be used anywhere. Features graduated lateral scale. Stands ¼" high when open; folds flat.

Power	Focal Distance	Lens Diameter	Item#	EACH Prices	
				1-2	3+
10X	1"	⅞"	<b>272-4050</b>	<b>\$11.95</b>	<b>\$9.96</b>



**G Bausch & Lomb® Aspheric Pocket Magnifier**

Pocket magnifier with slide-on plastic carrying case. Aspheric lens provides wide field of view at higher power than a normal lens. Measures approximately 2⅛" x 1⅜" x ⅝" when closed.

Power	Focal Distance	Lens Diameter	Item#	EACH Prices	
				1-2	3+
5X	2"	36mm	<b>272-5007</b>	<b>\$7.90</b>	<b>\$6.58</b>

**A Bausch & Lomb® Hastings Triplet Eye Loupe**

The best quality loupe from Bausch & Lomb in a lightweight watchmaker's style frame. The loupe has three layers of optical glass cemented together and a large field of view (out to the lens edges). Lens diameter: 15.8mm (almost  $\frac{5}{8}$ ").

Power	Focal Distance	Item#	Each
10X	1"	<b>272-1008</b>	<b>\$46.50</b>



**A**

**B, C Bausch & Lomb® Double-Lens Loupes**

Each provides two magnifications in a single loupe. Front lens screws off when not needed. Black finish with precision-ground and polished optical glass lenses.

Power	Focal Distance	Item#	Each
<b>B. 4X, 7X</b>	1½", 2½"	<b>272-1090</b>	<b>\$23.35</b>
<b>C. 8X, 18X</b>	½", 1¼"	<b>272-1091</b>	<b>26.40</b>



**B**



**C**

**D Bausch & Lomb® Single-Lens Loupes**

Lightweight, comfortable black frames hold precision-ground and polished optical glass lenses. Lens diameter: 25.4mm (1").

Power	Focal Distance	Item#	Each
<b>D. 10X</b>	1"	<b>272-1010</b>	<b>\$13.95</b>
7X	1½"	<b>272-1020</b>	<b>13.95</b>
5X	2"	<b>272-1030</b>	<b>13.95</b>
4X	2½"	<b>272-1040</b>	<b>13.95</b>



**D**

**E Bausch & Lomb® Headband**

For use with single- and double-lens Loupes. Black neoprene with Velcro end closures.

Description	Item#	Each
B&L Headband	<b>272-1005</b>	<b>\$8.75</b>



**E**

**F Bausch & Lomb® Hastings Triplet Loupes**

The best quality Loupes from Bausch & Lomb. Highly corrected for spherical and chromatic aberration. Each has a flat field. The Loupes have three layers of optical glass cemented together and a large field of view (out to the lens edges). A swing-away, nickel-plated case protects each loupe and serves as a handle.

Power	Focal Distance	Lens Diameter	Item#	Each
7X	1½"	19.8mm	<b>272-2039</b>	<b>\$37.95</b>
10X	1"	15.8mm	<b>272-2040</b>	<b>37.95</b>
14X	¾"	12.5mm	<b>272-2050</b>	<b>42.95</b>
20X	½"	8.3mm	<b>272-2060</b>	<b>46.50</b>



**F**

**G Bausch & Lomb® Coddington Loupes**

These Loupes have a thick single-lens construction with an internal diaphragm that provides a sharp, crisp image. Next to the Hastings Triplets in performance, although Coddington loupe lens diameters are much larger for equal powers (usable portion of each lens is approximately 60% of stated diameter). A swing-away, nickel-plated case protects each loupe and serves as a handle.

Power	Focal Distance	Lens Diameter	Item#	Each
10X	1"	19.8mm	<b>272-2010</b>	<b>\$24.50</b>
14X	¾"	15.8mm	<b>272-2020</b>	<b>26.90</b>
20X	½"	12.5mm	<b>272-2030</b>	<b>29.60</b>



**G**





**A**

**A Eschenbach Achromatic 10X Precision Metal Loupe**

A precision loupe made of matte chrome-plated brass. Features a 10X achromatic optical glass lens that delivers a color-corrected image, eliminating the prismatic effect that interferes with viewing accuracy. Meets EN ISO 9001 standards. Backed by a one-year manufacturer's warranty. Made in Germany.

Power	Focal Distance	Lens Diameter	Item#	Each
10X	5/8"	17mm	<b>272-3250</b>	<b>\$102.00</b>



**B**

**B Eschenbach Aplanatic 10X Precision Metal Loupe**

A precision loupe made of matte chrome-plated brass. Features a 10X aplanatic optical glass lens that delivers a distortion-free image over the entire field of view, even at the edges. Meets EN ISO 9001 standards. Backed by a one-year manufacturer's warranty. Made in Germany.

Power	Focal Distance	Lens Diameter	Item#	Each
10X	1"	23mm	<b>272-3255</b>	<b>\$61.50</b>



**C**

**C Eschenbach Aplanatic 10X Precision Fiberglass Loupe**

A precision folding loupe made of durable fiberglass-reinforced polyamide. Features a 10X aplanatic optical glass lens that delivers a distortion-free image over the entire field of view. Keeps out dust and lint when closed, protecting lens from damage. Meets EN ISO 9001 standards. Backed by a one-year manufacturer's warranty. Made in Germany.

Power	Focal Distance	Lens Diameter	Item#	Each
10X	1"	23mm	<b>272-3240</b>	<b>\$46.20</b>



**D**

**D 10X Green Hex Triplet Loupe**

Features generous lens for good viewing and hex shape for convenient gripping. Provides excellent optics across entire field of view with no edge distortion. Has distinctive green marbled metallic finish. Complete with leather pouch.

Description	Focal Distance	Lens Diameter	Item#	EACH Prices	
				1-2	3+
10X Green Loupe	1"	20.5mm	<b>272-3980</b>	<b>\$16.95</b>	<b>\$15.26</b>



**E**

**E Doublet Loupes**

Quality loupes at inexpensive prices. Each loupe has chrome-plated metal swing-away case. Complete with vinyl pouch. Made in China.

Power	Focal Distance	Lens Diameter	Item#	EACH Prices	
				1-2	3+
<b>E. 10X</b>	1"	21mm	<b>272-4031</b>	<b>\$8.95</b>	<b>\$8.06</b>
10X	1"	15mm	<b>272-4035</b>	<b>7.50</b>	<b>6.75</b>



**F**

**F Bausch & Lomb® Premoistened Lens Cleaning Tissues**

Antifog, antistatic, nonsilicone-based tissues treated with special surfactants to clean all glass and plastic lenses. Total of 100 individually wrapped tissues in convenient cardboard dispensing box that can be mounted on a bench or wall. Ideal for cleaning loupes, glasses, even computer screens. Each premoistened tissue measures 5" x 8". Box measures 9"L x 5 3/8"W x 2 3/8"D.

Description	Item#	Each
B&L Cleaning Tissues	<b>272-1001</b>	<b>\$12.40</b>



## A Dazor® Magnifying Lamp

Ideal for assembly, inspection and other high-precision work. Features 5" diameter 3-diopter crown optical glass lens with shade and 22W Circline cool white fluorescent tube for total visual freedom without eyestrain. Provides 75% magnification at 13" focal distance along with even, shadow-free light from all angles. Made of steel to endure years of rough use. Can be mounted horizontally or vertically on a bench, machine or wall. Available with a 28" heavy-duty lock-joint arm with three tension control knobs for reducing vibration or a 28" or 42" counterbalanced floating arm for easy positioning. Electrical: 115V, 60Hz (includes 9' cord with three-prong plug). UL listed. Backed by a five-year warranty.

Description	Item#	EACH Prices	
		1-2	3+
Lamp with 28" Lock-Joint Arm	<b>821-5534</b>	<b>\$170.00</b>	<b>\$164.90</b>
Lamp with 28" Floating Arm	<b>821-5529</b>	<b>190.00</b>	<b>184.30</b>
Lamp with 42" Floating Arm	<b>821-5517</b>	<b>190.00</b>	<b>184.30</b>



## B Add-A-Lens 1400

Designed specifically for use with the three-diopter lens found on the Dazor Magnifying Lamp (see above). Easy to attach. Increases magnification 50% for a total magnification of +275% at focal distance of 3<sup>3</sup>/<sub>4</sub>".

Description	Item#	Each
Add-A-Lens 1400	<b>821-5548</b>	<b>\$56.80</b>

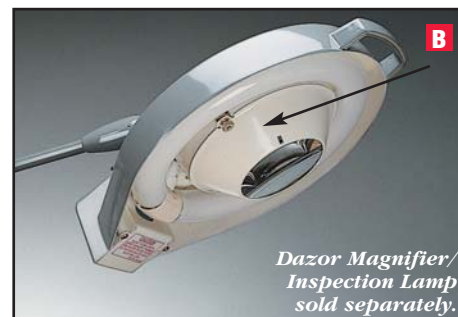

## C, D Dazor® Floating Arm Fluorescent Tube Lamps

Precision-built for home and workshop. Fluorescent tubes shed ample daylight lighting for most general work. Floating 24" arm permits rapid positioning of the light and stays where it is put without tightening screws or nuts. All-metal construction finished in baked enamel over protective bonderizing withstands everyday use. Universal base allows horizontal or vertical mounting. Two-Tube Lamp is supplied with two 15W daylight fluorescent tubes, and Three-Tube Lamp is supplied with three. Electrical: 115V, 60Hz (includes 7' cord with three-prong plug). UL listed. Backed by a five-year warranty.

Description	Item#	EACH Prices	
		1-2	3+
<b>C.</b> Two-Tube Lamp	<b>821-5530</b>	<b>\$159.00</b>	<b>\$154.23</b>
<b>D.</b> Three-Tube Lamp	<b>821-5535</b>	<b>187.00</b>	<b>181.39</b>
Replacement 15W Fluorescent Tube	821-5350	8.50	-



## E Dazor® Top-Mount Wide-Beam Incandescent Lamp

A longtime favorite of machine operators. Provides illumination over a large surface area. Features top-mounted swivel reflector with ventilated shell for comfortable handling and adaptable focusing. Has an inner aluminum reflector that is polished and anodized for surface protection and optimum lighting output. Ruggedly constructed with 31" steel ball-joint arm. Includes tabletop/wall mount and tabletop clamp. Approved for 100W bulb; 60W bulb (included) is recommended. Electrical: 115V, 60Hz. UL listed. Backed by a five-year warranty.

Description	Item#	EACH Prices	
		1-2	3+
Top-Mount Incandescent Lamp	<b>821-5567</b>	<b>\$153.00</b>	<b>\$148.41</b>





**A**

### **A Dazor® Halogen Lamp with Flex Arm**

Uses a 20W halogen bulb to produce a very intense light at the focal point of your workstation. The 2½" diameter head has a protective shield to guard against bulb breakage and proper ventilation to keep the reflector head cool. The 30" flexible arm allows easy positioning. Choose from weighted desk model and clamp-on model. Halogen bulb is rated to last 2,000 hours. Electrical: 115V, 60Hz. UL listed. Backed by a five-year warranty.

Description	Item#	EACH Prices	
		1-2	3+
<b>A. Weighted Desk Lamp</b>	<b>821-5555</b>	<b>\$146.00</b>	<b>\$141.62</b>
Clamp-On Lamp	<b>821-5560</b>	<b>130.00</b>	<b>126.10</b>
Replacement 20W Halogen Bulb	821-5549	11.50	—



**B**

### **B Dazor® Asymmetria Lamp**

A compact, energy-efficient fluorescent lamp for soft lighting. Produces an asymmetric light pattern that lowers reflective glare on work surfaces to reduce eyestrain. Features 18W fluorescent tube in head and 34" friction arm with three tension controls for precise positioning. Includes weighted base, C-clamp for benchtops up to 2¼" thick and 7' power cord with three-prong plug. Electrical: 115V, 60Hz. UL listed. Backed by a five-year warranty.

Description	Item#	Each
Black Lamp	<b>821-5542</b>	<b>\$95.00</b>
White Lamp	<b>821-5543</b>	<b>95.00</b>
Replacement 18W Fluorescent Tube	821-5305	19.80



**C**

### **C Magna Deluxe Fluorescent Lamp**

Features a 55W fluorescent bulb in an enclosed 20" head. Provides crisp, uniform light with maximum surface area. Built-in electronic ballast increases lumens. Head swivels 310° and tilts 210° for great flexibility. Heavy-duty arm with tempered steel springs and smooth-glide tension control knobs allows easy adjustment. Includes C-clamp for benchtops up to 2" thick and 5' power cord. Electrical: 115V, 60Hz. UL listed.

Description	Item#	Each
Magna Deluxe Lamp	<b>821-5029</b>	<b>\$135.00</b>



**D**

### **D Mighty Mag Magnifying Lamp**

With its extra-large 7.5" x 6.2" lens, Mighty Mag boasts the widest field of view of all our magnifying lamps. The 3-diopter lens provides 1.75X magnification for making objects appear 75% larger. Focal distance of 13" offers plenty of room to work under. Twin 9W daylight fluorescent tubes mounted on each side of lens shed light from every angle (can be switched on and off independently to control glare and shadows). Mar-resistant plastic housing is mounted to internal spring-balanced steel arm with 35" reach for easy positioning. Includes C-clamp for benchtops up to 2" thick and 5' power cord. Electrical: 115V, 60Hz. UL listed. Backed by a five-year warranty.

Description	Item#	Each
Mighty Mag Magnifying Lamp	<b>821-5045</b>	<b>\$120.00</b>



**E**

### **E ProVue Magnifying Lamp**

Ideal for inspection, assembly and other fine work. Features ultra-bright 22W circular fluorescent bulb and crystal-clear 3-diopter (1.75X) magnifying lens for 360° distortion-free viewing. Two optional add-on lenses provide more magnification: 3-diopter auxiliary lens adds another 1.75X, and 5-diopter swing-away lens adds another 2.25X. Lamp head measures 9" dia. with 5" dia. lens. The 45" spring-balanced arm locks in place via smooth-glide thumbscrews. Built to last with all-metal construction in powder-coated beige. Includes C-clamp for benchtops up to 2" thick and 5' power cord. Electrical: 115V, 60Hz. UL listed.

Description	Item#	Each
ProVue Magnifying Lamp	<b>821-5040</b>	<b>\$80.50</b>
Optional 3-Diopter Auxiliary Lens (+1.75X)	<b>821-5043</b>	<b>24.95</b>
Optional 5-Diopter Swing-Away Lens (+2.25X)	<b>821-5042</b>	<b>8.00</b>
Replacement 22W Circular Bulb	821-5044	10.80

**A Magna Twin-Tube Fluorescent Lamp**

These attractive, affordable workhorses use two or three 15W fluorescent tubes in a 19" head to produce uniform light. Convenient handle in head and flexible 42" spring-balanced arm with tension control knobs at joints allows precise placement. Built to last with all-metal construction in powder-coated beige. Includes on/off rocker switch on head, C-clamp for mounting on benchtops up to 2" thick and 5' power cord with polarized plug. Electrical: 115V, 60Hz. UL listed.

Description	Item#	Each
Magna Twin-Tube Lamp	<b>821-5027</b>	<b>\$75.00</b>
Magna Three-Tube Lamp	<b>821-5028</b>	<b>139.00</b>



**A**

**B Sirius Quartz Halogen Task Light with Flex Arm**

Provides high-intensity illumination for machining, manufacturing, assembly and inspection. Comes with a 20W MR16 halogen bulb yet accepts up to a 50W bulb. Head can be moved up and down. Flexible arm with 20½" reach resists vibration, staying put without drifting. Includes on/off rocker switch on head, C-clamp for mounting on benchtops up to 1¾" thick and 5' power cord. Electrical: 115V, 60Hz. UL listed.

Description	Item#	Each
Sirius Quartz Task Light	<b>821-5025</b>	<b>\$65.00</b>



**B**

**C Aurora Combo Lamp**

Features a 60W incandescent bulb, 22W circular fluorescent bulb and 9½" shade to enhance color perception, eliminate glare and reduce eyestrain. Use just one light source at a time for general work, or use them together to create optimal conditions for examining fine work. Adjustable 42" spring-balanced arm with tension control allows you to position head exactly where you need. Built to last with all-metal construction in powder-coated beige. Includes C-clamp for mounting on benchtops up to 2" thick and 5' power cord. Electrical: 115V, 60Hz. UL listed.

Description	Item#	Each
Aurora Combo Lamp	<b>821-5035</b>	<b>\$57.00</b>



**C**

**D OptiVue Magnifying Lamp**

Combines illumination and magnification in one compact unit. Features a powerful 12W circular T4 fluorescent bulb surrounding a 3-diopter (1.75X) magnifying lens. Just flip up the lens cover to transform OptiVue from desk lamp to inspection lamp. Lamp head measures 6" dia. with 3½" dia. lens. Highly flexible gooseneck stays put and will not kink, twist or slip. Made of heavy-duty plastic with 6½" dia. weighted base for stability. Includes 5' power cord with polarized plug. Electrical: 115V, 60Hz. UL listed.

Description	Item#	Each
OptiVue Magnifying Lamp	<b>821-5030</b>	<b>\$32.00</b>
Replacement 12W Circular Bulb	821-5037	7.95



**D**

**E Elumina Task Lamp**

With its classic design and contemporary brushed silver finish, Elumina complements any decor. Uses a 50W halogen bulb shielded with UV filter glass. Adjustable arm extends 23" from 6" dia. weighted base. Built-in 4" dia. shade can be rotated to focus light where you want. Joints lock firmly into place with smooth-glide thumbscrews. Includes 5' power cord with in-line on/off switch and polarized plug. Electrical: 115V, 60Hz. UL listed.

Description	Item#	Each
Elumina Task Lamp	<b>821-5020</b>	<b>\$28.00</b>



**E**

## A, B Multi Lamp with Flex Arm



Very popular with machine operators. Lamp with vinyl-covered flexible arm can be mounted virtually anywhere extra light is needed. Comes with three different mounting buttons. The patented nylon mounting button only takes up about 1" of space and can be mounted on any flat surface. Simply slide the base of the lamp arm over the mounting button, and the lamp is firmly locked in place. Includes studs for mounting Multi Lamp on either horizontal or vertical surface. Uses up to 100W bulb (not included). Electrical: 110V.

### Features:

- Lightweight, durable construction.
- Center-suspended reflector and socket keeps outer shade cool.
- Base rotates 360°.
- Shade rotates 1½ turns.
- Heavy-duty jacketed cord with three-prong plug.
- Optional Magnifier Attachment with shade-mounted, ground-glass magnifying lens (double lens: 2X and 4X).
- Easy installation in only a few minutes.
- Cleans with soap and water.

Description	Item#	Each
A. Multi Lamp with 18" neck	<b>821-4500</b>	<b>\$55.35</b>
B. Multi Lamp with 24" neck	<b>821-4510</b>	<b>58.30</b>
Optional Magnifier Attachment	<b>821-4530</b>	<b>35.70</b>
Replacement Steel Mounting Button (for vibrating surfaces)	821-4540	3.15
Replacement Right-Angle Bracket	821-4550	4.05



## C Bausch & Lomb® Illuminating Stand Magnifier

An all-purpose, large-field magnifier with a wide range of uses from inspection to general repair work. Both lens and light are adjustable. With lens tilted, small handheld objects can be worked on or inspected. When the lens is parallel to the work surface, anything placed beneath it is in focus.

Lens is 2X with 7/8" diameter insert for 6X magnification. Measures 3¾" x 2". Bulb is 7W GE 7C7 (or equivalent). Stand is chromium-plated steel rod. Lens mount and lamp housing are black plastic. Plastic sleeves on feet help protect even highly finished surfaces. Electrical: 110/120V, 50/60Hz.

Description	Item#	EACH Prices	
		1-2	3+
Illuminating Stand Magnifier	<b>272-5010</b>	<b>\$41.60</b>	<b>\$34.67</b>



## D Econo Magnifying Lamp

The affordable solution for viewing small, detailed areas. Provides 5X magnification and cool white light to reduce eyestrain, helping you work faster. Flexible gooseneck allows easy positioning. Heavy metal base with nonslip pad ensures stability. Flip-down cover keeps dust off lens when not in use.

Description	Item#	Each
Econo Magnifying Lamp	<b>821-5010</b>	<b>\$39.95</b>



## E Flip Lamp

A compact 13W fluorescent lamp ideal for the workshop. Unique swivel arm with 180° range delivers light at the precise angle you need: just raise arm to turn on lamp, and lower to turn off. Easy to use on crowded benchtops. Lightweight yet sturdy. Measures 10½" high with 3¼" square base. Includes 6' power cord with polarized plug. Electrical: 120V, 60Hz.

Description	Item#	Each
Flip Lamp	<b>821-5006</b>	<b>\$16.95</b>



**Imaging Systems – Ideal for capturing digital images of your small parts!**

Gesswein offers several high-quality imaging systems for capturing digital images of your small parts and components. Choose from top-of-the-line models all the way down to economical ones, and combine with your digital camera. All provide exceptional lighting to ensure images turn out clean and crisp. Use the resulting images for inventory management, repair documentation and much more—you can even include them in printed and electronic marketing materials. We even offer proprietary software for image management. Whatever your imaging needs, we have the right system for you!

**A The BOX™ II Advanced Light Box**

The BOX II offers several high-end features: extra-large imaging chamber allows easy adjustment of compositions; built-in horizontal and vertical camera tracks let you shoot pictures from any desired angle with a compatible digital camera; independently controlled lights in the top, front doors, back and sides ensure you have the right lighting environment for every composition; motorized lighted platform tilts 30° and rotates 180° for additional still-shot and video applications; and halogen and LED accent lights really bring out the sparkle in your images. Includes elevated and tilted platforms with remote control, three colored composition plates, assorted holding fixtures and positioning wax. Electrical: 110V. Measures 20¼"W x 22¼"D x 20"H with 14"W x 17½"D x 10"H chamber and 12½" dia. platform.

**Features:**

- Extra-large imaging chamber for easy composition adjustments
- Horizontal and vertical camera tracks for optimal shot angles
- Independent light switches for full lighting control
- Motorized lighted platform for still-shot and video applications
- Three halogen accent lights in left, right and back sides
- One ultra-bright LED accent light in top
- Built-in Dual-LED Sparkle Light

Description	Item#	Each
The BOX II	<b>817-0499</b>	<b>\$3,595.00</b>



*Camera not included.*

**B, C MEDALight® Mini Studio**

This mini studio provides a versatile 5000°K lighting environment for shooting your parts. With its compact size and multiple adjustable light sources, it gives you the flexibility you need to work with a wide range of compositions without using too much space (30" x 30" area required).

Features 17" x 23" imaging platform, durable shooting table frame, translucent diffusion tabletop (attaches securely to frame), innovative 48/32W bottom/back lighting unit, 48W large fluorescent light panel and two 32W small fluorescent light panels with barn-door reflectors. Comes complete with removable diffusion material for hard, soft or mixed lighting, top light stand with boom arm, two swing-arm light mounts and all necessary mounting hardware. Electrical: 120V, 60Hz. Roof diffuser sold separately (see below).

**Features:**

- Provides full control over shadows and highlights in images
- Perfect size for shooting a wide variety of compositions
- Unique 5000°K fluorescent foldaway bottom/back lighting unit
- Fluorescent light panels with barn-door reflectors
- Removable diffusion material for hard, soft or mixed lighting

Description	Item#	Each
<b>B. Mini Studio</b>	<b>817-0843</b>	<b>\$1,250.00</b>
<b>C. Roof Diffuser</b>	<b>817-0876</b>	<b>49.95</b>







**A MEDALight® Large Light Box**

A full-size light box for shooting a wide range of items. Features 11" x 16" imaging platform; five individually controllable, dimmable 5000°K fluorescent lights in front, rear, sides and bottom; and infinity curve from bottom platform to rear panel for seamless background transition.

Includes removable front door, universal camera bracket, power adapter, leatherette stand, positioning wax, six colored background papers and two black side masks. Electrical: 120V, 60Hz. Measures 19"W x 15"D x 14"H.

Description	Item#	Each
Large Light Box	<b>817-0842</b>	<b>\$950.00</b>

**B MEDALight® Medium Light Box**

This mid-range light box offers great control and flexibility at a reasonable price. Features 9" x 12" imaging platform; three individually controllable, dimmable 5000°K fluorescent lights in front, rear and bottom; light-reflecting sides; and infinity curve from bottom platform to rear panel for seamless background transition.

Includes removable front door, universal camera bracket, power adapter, leatherette stand, positioning wax, six colored background papers and two black side masks. Electrical: 120V, 60Hz. Measures 14½"W x 13"D x 12"H.

Description	Item#	Each
Medium Light Box	<b>817-0839</b>	<b>\$695.00</b>

**C MEDALight® Small Light Box**

An economical, portable light box for shooting small items. Features 5½" x 8" imaging platform; two 5000°K fluorescent lights in rear and bottom (not individually controllable); light-reflecting front and sides; and compact, space-saving design.

Includes removable front door, universal camera bracket, power adapter, leatherette stand, positioning wax and nylon carrying case. Electrical: 100–240V, 50/60Hz. Measures 11"W x 8"D x 9"H.

Description	Item#	Each
Small Light Box	<b>817-0844</b>	<b>\$395.00</b>

**D The LiteRoom™ Kit**

The easy-to-use lighting solution for shooting hard-to-move items. Produces crisp, consistent images. Includes 24"W x 32"D x 17"H LiteRoom tent with 22" x 30" imaging area, two light heads, two 250W tungsten lightbulbs, two light stands and tent carrying bag; all you need is a camera and tripod. Extremely easy to set up and break down.

The translucent LiteRoom tent helps create a soft wraparound lighting environment that results in even, reflection-free photos. Gives you a wide range of camera angle choices: take pictures from overhead through the circular opening or from the front through the multiple-zippered opening. Features a vestibule interior with Velcro tabs for attaching a variety of sweep backdrops. Best of all, the tent is bottomless, so you can move it without disturbing your composition. The professional-grade lights with stands provide precise, adjustable lighting. Made to last with replaceable tungsten lightbulbs for years of trouble-free use. Electrical: 110V.

Description	Item#	Each
The LiteRoom Kit	<b>817-0858</b>	<b>\$395.00</b>



**A Photo eBox Plus**

Offers the most control of all the Photo eBoxes. Features both 6500°K fluorescent and 3000°K halogen accent lighting. Includes a main power switch and five light switches: four switches for controlling the four fluorescent lights individually and another switch for controlling the three halogen accent lights. Allows you to shoot from the top at a variety of angles using the included L-shaped and magnetic camera mounts or from the front through the sliding camera opening. Electrical: 110V. Measures 19¾"W x 13¼"D x 13"H with 10" x 13½" imaging platform.

Description	Item#	Each
Photo eBox Plus	<b>817-0846</b>	<b>\$1,095.00</b>



**B Photo eBox II**

A great mid-range unit. Features both 6500°K fluorescent and 3000°K halogen accent lighting. Includes two light switches: one switch for controlling the four fluorescent lights and another switch for controlling the three halogen accent lights. Allows you to shoot from the top at a variety of angles using the included L-shaped and magnetic camera mounts or from the front through the sliding camera opening. Electrical: 110V. Measures 19¾"W x 13¼"D x 13"H with 10" x 13½" imaging platform.

Description	Item#	Each
Photo eBox II	<b>817-0845</b>	<b>\$895.00</b>



**C Photo eBox**

The most economical Photo eBox. Features 6500°K fluorescent lighting only. Includes a single main power switch for turning all four lights on or off at once. Allows you to shoot from the top at a variety of angles using the included L-shaped and magnetic camera mounts or from the front through the sliding camera opening. Electrical: 110V. Measures 19¾"W x 13¼"D x 13"H with 10" x 13½" imaging platform.

Description	Item#	Each
Photo eBox	<b>817-0817</b>	<b>\$795.00</b>



**D Gem eBox**

Offers quality lighting at an affordable price while saving valuable space. Features three 6500°K fluorescent lights, two 3200°K halogen accent lights and a special 5800°K 15-LED accent light. Includes a main power switch and three light switches for controlling the three types of lights. Allows you to shoot from the top using the included L-shaped camera mount or from the front through the removable door. Comes complete with assorted stands and positioning wax. Electrical: 110V. Measures 15"W x 7½"D x 10½"H.

Description	Item#	Each
Gem eBox	<b>817-0497</b>	<b>\$465.00</b>



**E GIS Pro Imaging Software**

Our proprietary imaging software helps you capture, edit, label and organize all your digital images for simple archiving and retrieving. An outstanding management tool.

Description	Item#	Each
GIS Pro	<b>817-0427</b>	<b>\$99.95</b>





**A**

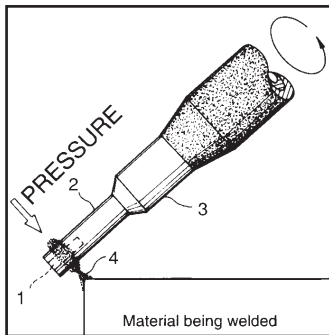

*Edge weld*

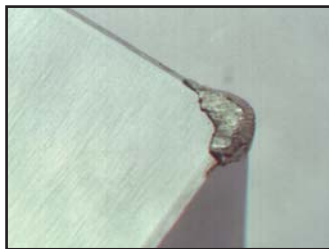

*Corner weld*

## The Microwelding Method with Weldmax 350

The Weldmax 350 Microwelder uses up to 1,600 amps, released in short pulses 200 times a minute. As gentle electrode pressure is applied to the damaged area, these pulses fuse metal powder, sheet or wire weld material to the mold under repair. Weld material containing alloying properties of the ferrous metal being welded is first fused then welded into the base metal by a systematic and controlled supply of amperage discharges. This process builds up weld material, producing a strong weld that penetrates the mold surface. The welding process can be fine-tuned by adjusting frequency of pulses and output current.

### **A** Weldmax 350 Microwelder

**Increase mold life and reduce repair costs by up to 85%!**

Perform controlled repairs on very small mold areas with the fast and powerful Weldmax 350 Microwelder. Its modern electronic controls help produce strong, homogeneous weld patterns, even under the most difficult working conditions. Weldmax 350's precision function, which provides very short-duration pulses, permits ultimate control of tiny part welding. Unit features six push-button weld material selections and three push-button amperage selections for easy, automatic welding. Includes automatic operation override for manual welding with up to 1,600 amps.

#### Advantages of Microwelding

The process emits no heat beyond the repair area, so there's no metal stress, distortion or shrinkage. Weld material is minimal, which makes hand and machine finishing easier. Hardening and plating can be done after welding. Only gentle pressure is required on welding electrodes, preventing the formation of cavities or pinholes.

Suitable for all forms of small mold damage. No need for other types of welding (e.g., argon or laser welding). Safe and easy to operate—no special training necessary. No harmful welding fumes or toxic gases are emitted. No scaling or flaking occurs. High-quality welding alloys are free of impurities to ensure resulting welds are reliable.

#### Industrial Uses

Suitable for use on molds and dies for plastics and rubber, die casting molds and compression molds. For all steels, stainless steels and other ferrous metals. Not recommended for use on press dies, and will not weld on aluminum molds.

#### Applications:

- Building up parting lines, mold seams, three-point corners and edges
- Filling pores and repairing pinholes
- Eliminating characteristic holes, sags or pores following the argon welding process
- Repairing slides, ejectors, core pins, flat cores and mold edges
- Eliminating machining defects caused by milling, countersinking and wire EDM
- Modifying designs of inserts, cores and prototype molds

#### Specifications:

Input Voltage	120V or 230V AC, 50/60Hz
Consumable Power	1,500VA
Control System	SCR switching system
Timer	200 min.
Output Power	1200W
Output Voltage	0-10V
Output Current	0-1,600A, 0-700A precision function
Auto Function	Current discharge control for tack or continuous welding
Dimensions	6½"W x 16¾"D x 15⅛"H (165 x 425 x 385mm)
Weight	39.5 lbs. (18kg)

Description	Item#	Each
<b>A.</b> Weldmax 350, 120V	<b>511-0010</b>	<b>\$6,485.00</b>
Weldmax 350, 230V	<b>511-0015</b>	<b>6,485.00</b>





## **A** Accessory Set – Included with Weldmax 350.

Weldmax 350 comes ready to use with a generous assortment of magnetic and nonmagnetic electrodes, electrode holders and sheet and powder welding materials—everything you need to weld large molds made of softer steels and small molds made of harder steel alloys (see list below for complete list of Weldmax 350 components). A complete range of accessories and replacement parts are also available, including additional magnetic and nonmagnetic electrodes (see pp. 274-275), electrode holders (see pp. 274-275) and wire, sheet and powder welding materials in various alloys (see pp. 276-277).

### Components:

- Power Pack and Cord
- On/Off Foot Switch
- Grounding Cord, 6½'
- Electrode Holder Cord, 6½'
- Replacement Fuse, 2A
- Copper Grounding Plate, 2 x 20 x 100mm
- Safety Goggles and Gloves
- Screw and Wrench Set
- Sheet Metal Shears
- Masking Tape
- Tool Box
- Magnetic Electrodes:  
  - ø2 x 50, 3 x 50, 4 x 50, 4 x 60mm
- Nonmagnetic Electrodes:  
  - ø2 x 50, 3 x 50, 4 x 50,
  - flat 1.2 x 5 x 35mm
- Brown Electrode Holders for magnetic electrodes: ø2, 3, 4mm
- Black Electrode Holders for nonmagnetic electrodes: ø2, 3, 4, 5mm
- Insert Collet for ø5mm nonmagnetic electrode holder (for holding flat 1.2 x 5 x 35mm electrode)
- Metal Welding Strips (10 pieces each):  
  - NTA1 (Ni alloy, HV 135),  
0.1 x 30 x 70mm;
  - NTA2 (Ni alloy, HV 135),  
0.2 x 30 x 70mm;
  - NAK80 (NAK80, HRC 38–40),  
0.1 x 5 x 100mm
- Metal Welding Powder (40 grams each):  
  - N51 (Hardened SKH51,  
HRC 63);
  - N80 (Prehardened NAK80/PHM50,  
HRC 38–40)



*Three-point corner welding*



*Buildup process*

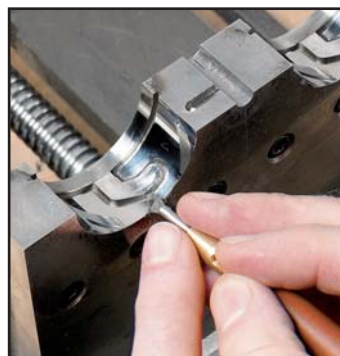

*In-press mold repair*

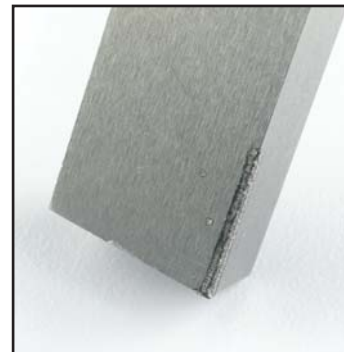

*Repaired edge*

## Weldmax Electrodes and Electrode Holders

Weldmax Electrodes are available in two forms: magnetic and nonmagnetic. Magnetic electrodes provide an easy method for placing and welding metal powder. Nonmagnetic electrodes are used to tack in place sheet and wire and to weld sheet, wire and powders. All nonmagnetic electrodes can be shaped to conform to the mold surfaces being repaired to improve the efficiency of the welding process. Electrode Holders are color-coded for easy distinction: brown to hold magnetic electrodes, black to hold nonmagnetic electrodes. Use standard 15mm O.D. for all normal repair work and slim 12mm O.D. for repairs in narrow areas or deep recesses. All electrodes and holders fit Weldmax 350.



### A, B, C Magnetic Electrodes

Tip Shape	Dimensions (d x L x D)	Use Magnetic Electrode Holder	Item#	Each
A. Round	2 x 50 x 3mm	3mm slim, 3mm std.	<b>511-0180*</b>	<b>\$66.80</b>
	3 x 50 x 3mm	3mm slim, 3mm std.	<b>511-0181*</b>	<b>74.20</b>
	4 x 60 x 4mm	4mm std.	<b>511-0182*</b>	<b>81.65</b>
B. Straight	5 x 60 x 5mm	5mm std.	<b>511-0183</b>	<b>89.00</b>
	2 x 50 x 2mm	2mm slim, 2mm std.	<b>511-0185</b>	<b>67.85</b>
	3 x 50 x 3mm	3mm slim, 3mm std.	<b>511-0186</b>	<b>74.20</b>
C. Taper	4 x 50 x 4mm	4mm std.	<b>511-0187*</b>	<b>82.70</b>
	5 x 50 x 5mm	5mm std.	<b>511-0188</b>	<b>89.00</b>
	2.5 x 50 x 4mm	4mm std.	<b>511-0189</b>	<b>80.50</b>
	2.5 x 50 x 5mm	5mm std.	<b>511-0190</b>	<b>91.00</b>

\*Supplied with Weldmax 350.

### D Brown Holders for Magnetic Electrodes – Slim and Standard

Style	Dimensions (O.D. x L)	Item#	Each
2mm slim	12 x 125mm	<b>511-0214</b>	<b>\$142.00</b>
3mm slim	12 x 125mm	<b>511-0215*</b>	<b>152.65</b>
2mm std.	15 x 125mm	<b>511-0210</b>	<b>142.00</b>
3mm std.	15 x 125mm	<b>511-0211</b>	<b>142.00</b>
4mm std.	15 x 125mm	<b>511-0212*</b>	<b>142.00</b>
5mm std.	15 x 125mm	<b>511-0213</b>	<b>142.00</b>

\*Supplied with Weldmax 350.

### E - H Nonmagnetic Electrodes

Tip Shape	Dimensions (L x D)	Use Nonmagnetic Electrode Holder	Item#	Each
E. Round	50 x 2mm	2mm slim, 2mm std.	<b>511-0195*</b>	<b>\$59.40</b>
	50 x 3mm	3mm slim, 3mm std.	<b>511-0196*</b>	<b>67.85</b>
	50 x 4mm	4mm std.	<b>511-0197*</b>	<b>74.20</b>
	50 x 5mm	5mm std.	<b>511-0198</b>	<b>89.00</b>
F. Straight	50 x 2mm	2mm slim, 2mm std.	<b>511-0199</b>	<b>59.35</b>
	50 x 3mm	3mm slim, 3mm std.	<b>511-0200</b>	<b>71.00</b>
	50 x 4mm	4mm std.	<b>511-0201</b>	<b>74.20</b>
	50 x 5mm	5mm std.	<b>511-0202</b>	<b>89.00</b>
G. Thin Chisel	50 x 2mm	2mm slim, 2mm std.	<b>511-0205</b>	<b>64.45</b>
H. Thin Round	50 x 2mm	2mm slim, 2mm std.	<b>511-0206</b>	<b>64.45</b>

\*Supplied with Weldmax 350.

### I Black Holders for Nonmagnetic Electrodes – Slim and Standard

Style	Dimensions (O.D. x L)	Item#	Each
2mm slim	12 x 125mm	<b>511-0324*</b>	<b>\$143.00</b>
3mm slim	12 x 125mm	<b>511-0325*</b>	<b>143.00</b>
2mm std.	15 x 125mm	<b>511-0320</b>	<b>143.00</b>
3mm std.	15 x 125mm	<b>511-0321</b>	<b>143.00</b>
4mm std.	15 x 125mm	<b>511-0322*</b>	<b>143.00</b>
5mm std.	15 x 125mm	<b>511-0323*</b>	<b>143.00</b>

\*Supplied with Weldmax 350.

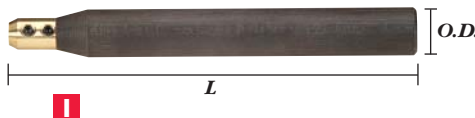
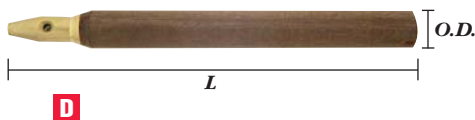



**A Flat Nonmagnetic Electrodes**

Tip Shape	Dimensions (T x W x L)	Use Electrode Holder	Item#	Each
Flat	1.2 x 5 x 35mm	5mm std.	<b>511-0203*</b>	<b>\$59.35</b>
	2.2 x 5 x 35mm	5mm std.	<b>511-0204</b>	<b>89.00</b>



**B Insert Collets for Flat Nonmagnetic Electrodes**

Collet	Dimensions (T x W x O.D.)	Use Electrode Holder	Item#	Each
For Flat 1.2T	1.2 x 5 x 5mm	5mm std.	<b>511-0218*</b>	<b>\$52.50</b>
For Flat 2.2T	2.2 x 5 x 5mm	5mm std.	<b>511-0219</b>	<b>52.50</b>

\*Supplied with *Weldmax 350*.



**C Black Holder for Insert Collets and Flat Nonmagnetic Electrodes**

Style	Dimensions (O.D. x L)	Item#	Each
5mm std.	15 x 125mm	<b>511-0323</b>	<b>\$143.00</b>

Supplied with *Weldmax 350*.

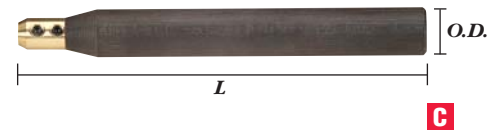

**D Meiji Stereo Zoom Microscopes**

**Standard Binocular and Camera-Ready Trinocular Styles**

From the premier optics manufacturer in Japan, these microscopes feature a Greenough optical design and high-resolution optics free of chromatic and spherical aberrations for yielding crystal-clear upright and unreversed stereoscopic images with rich contrast, impressive brightness and true-to-life color. Boast great depth of field and image flatness for accurate viewing and long working distances for ample workspace. Ideal for inspection of fine details.

Lightweight yet durable all-metal aluminum alloy bodies with premium components and chemical-resistant finishes provide stability and durability for a lifetime of dependable use. The 45°-inclined observation tubes with adjustable interpupillary distance and diopter tubes eliminate eyestrain.

Acrobat Boom Stand with friction arms, focus block and padded headrest ensures superb flexibility and comfort. Entire assembly can be easily positioned and quickly swung away when not in use. Friction arms lock in place when needed. Focus block securely holds microscope body. Padded headrest reduces neck and back fatigue.

Ring Light with extra-bright circular fluorescent bulb provides cool, glare-free illumination. Fits many other microscopes besides those from Meiji. Electrical: 115V.

**Features:**

- Binocular and Trinocular styles that can be rotated 360° and locked in any position
- High-resolution optics for yielding upright and unreversed stereoscopic images
- Rugged all-metal bodies and components designed to last a lifetime
- Ergonomically positioned bilateral zoom controls
- Interpupillary distance adjustment from 54–75mm
- Dual dioptic adjustment (±5 diopters) for maintaining focus throughout zoom range

**Specifications:**

Body Style	Binocular or Trinocular, each with 360° rotation
Zoom Control	Dual, graduated, bilateral mount
Zoom Range	0.7–4.5X (0.35–2.25X with 0.5X objective lens)
Magnification	7–45X (3.5–22.5X with 0.5X objective lens)
Field of View	32.8–5.1mm (65.6–10.2mm with 0.5X objective lens)
Working Distance	93mm (Binocular/Trinocular with 0.5X objective lens: 150/170mm)
Interpupillary Distance	Adjustable from 54–75mm
Dioptic Adjustment	Dual (±5 diopters)

Description	Item#	Each
<b>D. Binocular Microscope with Acrobat Stand and Ring Light</b>	<b>271-3029</b>	<b>\$1,830.00</b>
Trinocular Microscope with Acrobat Stand and Ring Light*	<b>271-3067</b>	<b>2,375.00</b>

\*Designed for photo and video applications. When the beamsplitter is engaged, it does not obstruct the eyetubes; all three view ports are lighted for simultaneous use. Can be used with most cameras, including digital, SLR, digital SLR and CCD. Call for available adapters.



Ring Light



Ring Light Circuline Bulb

## Welding Materials

Welding materials are available in atomized metal powder (standard and precise grades for use with precision function), sheet metal (0.1–0.2mm thick) and wire (0.2–0.6mm dia. and 0.015–0.025" dia.). The welding materials are particularly suitable for use with rolled, prehardened, quenched and tempered, free cutting steels and stainless steels. Each has a different hardness and metal mold application. Ideally, weld material hardness should match base metal hardness. As a rule, however, very good results can be achieved with N80 powder or NAK80, NTA1 or NTA2 sheet (supplied with Weldmax). These produce strong homogeneous welds on most molds. Molds for small parts usually made of harder alloys should be welded with N51 powder (supplied with Weldmax) or harder sheet material.



### A Standard Welding Powder – For repairing most damaged areas

Style	Material	Hardness	Application	Item#	40g Pkg.
N40	Ni-Cr Alloy	HRC 36–42	All Mold Steels	<b>511-0220</b>	<b>\$63.50</b>
N90	Ni Alloy	HRC 16–20	All Mold Steels	<b>511-0221</b>	<b>63.50</b>
N50	Ni Alloy	HRC 47–53	All Mold Steels	<b>511-0222</b>	<b>63.50</b>
N13	Ni Alloy	HRC 10–15	All Mold Steels	<b>511-0223</b>	<b>63.50</b>
NS8	SS 304	HV 200 Max.	All Mold Steels	<b>511-0224</b>	<b>65.00</b>
NS12	SS 316	HV 200 Max.	All Mold Steels	<b>511-0225</b>	<b>65.00</b>
N11	Hardened SKD11	HRC 50 Min.	A-2	<b>511-0227</b>	<b>101.50</b>
N70	Fe (Iron)	HRC 50–55	Cast Iron	<b>511-0229</b>	<b>79.95</b>
N51	Hardened SKH51	HRC 63 Min.	D-2	<b>511-0226*</b>	<b>106.00</b>
N11	Hardened SKD11	HRC 50 Min.	D-2	<b>511-0227</b>	<b>101.50</b>
N61	Hardened SKD61	HRC 53 Max.	H-13	<b>511-0228</b>	<b>101.50</b>
N51	Hardened SKH51	HRC 63 Min.	M-2	<b>511-0226*</b>	<b>106.00</b>
N80	Prehardened NAK80/PHM50	HRC 38–40	P-20	<b>511-0230*</b>	<b>106.00</b>
N80	Prehardened NAK80/PHM50	HRC 38–40	P-21	<b>511-0230*</b>	<b>106.00</b>
N55	Prehardened NAK55/PHM1	HRC 38–41	P-21	<b>511-0231</b>	<b>101.50</b>
N39	Stavax/PD555	HRC 50–52	STAVAX	<b>511-0233</b>	<b>101.50</b>
N51	Hardened SKH51	HRC 63 Min.	S-7	<b>511-0226*</b>	<b>106.00</b>
N38	HPM38/PD555	HRC 30 Max.	SS 420	<b>511-0232</b>	<b>101.50</b>

\*Supplied with Weldmax 350.



### B Precision Function Welding Powder – Finely graded for welding small parts

Style	Material	Hardness	Application	Item#	40g Pkg.
N14	SCM, PHM2-2311	HRC 30+	All Mold Steels	<b>511-0247</b>	<b>\$140.00</b>
N15	SNCM, HPM17	HRC 30–35	All Mold Steels	<b>511-0248</b>	<b>140.00</b>
N16	SNCM, 2767	HRC 30–35	All Mold Steels	<b>511-0249</b>	<b>140.00</b>
SA60	UDHOLM ASP	HRC 58–72	ASP	<b>511-0239</b>	<b>140.00</b>
SP11	Hardened SKD11	HRC 50	A-2	<b>511-0241</b>	<b>198.00</b>
SP51	Hardened SKH51	HRC 63 Min.	D-2	<b>511-0240</b>	<b>198.00</b>
SP11	Hardened SKD11	HRC 50	D-2	<b>511-0241</b>	<b>198.00</b>
SP61	Hardened SKD61	HRC 53 Max.	H-13	<b>511-0242</b>	<b>198.00</b>
N5	2162	HRC 54–56	H-13	<b>511-0245</b>	<b>140.00</b>
SP51	Hardened SKH51	HRC 63 Min.	M-2	<b>511-0240</b>	<b>198.00</b>
SP80	Prehardened NAK80/PHM50	HRC 38–40	P-20	<b>511-0243</b>	<b>204.00</b>
SP80	Prehardened NAK80/PHM50	HRC 38–40	P-21	<b>511-0243</b>	<b>204.00</b>
SP55	Prehardened NAK55/PHM1	HRC 38–41	P-21	<b>511-0244</b>	<b>204.00</b>
N6	SKD6, 2343	HRC 38–45	P-21	<b>511-0246</b>	<b>140.00</b>
SP51	Hardened SKH51	HRC 63 Min.	S-7	<b>511-0240</b>	<b>198.00</b>

## A Welding Sheet and Strips

Size (mm)	Material	Hardness	Application	Item#	Pkg. of 10
0.1 x 30 x 70	NTA1 (Ni Alloy)	HV 135	All Mold Steels	<b>511-0280*</b>	<b>\$37.10</b>
0.2 x 30 x 70	NTA2 (Ni Alloy)	HV 135	All Mold Steels	<b>511-0281*</b>	<b>37.10</b>
0.1 x 30 x 70	NS1 (SS Alloy)	HRB 90	All Mold Steels	<b>511-0282</b>	<b>37.10</b>
0.2 x 30 x 70	NS2 (SS Alloy)	HRB 90	All Mold Steels	<b>511-0283</b>	<b>37.10</b>
0.2 x 5 x 100	NT6	HRC 30	All Mold Steels	<b>511-0268</b>	<b>132.30</b>
0.1 x 5 x 100	SKD61	HRC 53	H-13	<b>511-0275</b>	<b>113.45</b>
0.2 x 5 x 100	SKD61	HRC 53	H-13	<b>511-0276</b>	<b>113.45</b>
0.1 x 5 x 100	NAK80	HRC 38-40	P-20	<b>511-0270*</b>	<b>108.00</b>
0.2 x 5 x 100	NAK80	HRC 38-40	P-20	<b>511-0260</b>	<b>108.00</b>
0.1 x 5 x 100	HPM2	HRC 30-33	P-20	<b>511-0271</b>	<b>108.00</b>
0.2 x 5 x 100	HPM2	HRC 30-33	P-20	<b>511-0261</b>	<b>104.00</b>
0.2 x 5 x 100	MAS1	HRC 50-53	P-20	<b>511-0263</b>	<b>104.00</b>
0.2 x 5 x 100	YAG	HRC 50-53	P-20	<b>511-0265</b>	<b>108.00</b>
0.1 x 5 x 100	NAK80	HRC 38-40	P-21	<b>511-0270*</b>	<b>108.00</b>
0.2 x 5 x 100	NAK80	HRC 38-40	P-21	<b>511-0260</b>	<b>108.00</b>
0.1 x 5 x 100	NAK55	HRC 38-40	P-21	<b>511-0272</b>	<b>104.00</b>
0.2 x 5 x 100	NAK55	HRC 38-40	P-21	<b>511-0266</b>	<b>108.00</b>
0.1 x 5 x 100	HPM50	HRC 38-40	P-21 Improved	<b>511-0273</b>	<b>104.00</b>
0.2 x 5 x 100	HPM50	HRC 38-40	P-21 Improved	<b>511-0262</b>	<b>108.00</b>
0.2 x 5 x 100	STAVAX	HRC 50-52	STAVAX	<b>511-0264</b>	<b>104.00</b>
0.1 x 5 x 100	HPM38	HRC 30-33	SS 420	<b>511-0274</b>	<b>108.00</b>
0.2 x 5 x 100	HPM38	HRC 30	SS 420	<b>511-0267</b>	<b>104.00</b>

\*Supplied with Weldmax 350.

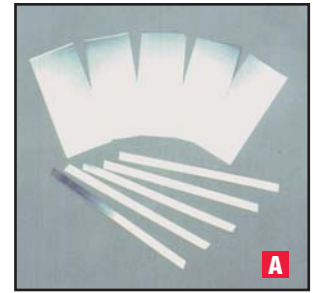

## B Welding Wire – inch diameters

Available in three diameters: 0.025", 0.020" and 0.015". Measure 6" (150mm) long. Sold in packages of 25.

Material	Hardness	Application	0.025 Dia. Item#	Pkg. of 25	0.020 Dia. Item#	Pkg. of 25	0.015 Dia. Item#	Pkg. of 25
SS 420	HRC 50	All Mold Steels	<b>511-0351</b>	<b>\$15.85</b>	<b>511-0359</b>	<b>\$19.00</b>	<b>511-0367</b>	<b>\$22.25</b>
A-2	HRC 45-50	A-2	<b>511-0353</b>	<b>15.85</b>	<b>511-0361</b>	<b>19.00</b>	<b>511-0369</b>	<b>22.25</b>
H-13	HRC 58-60	H-13	<b>511-0352</b>	<b>15.85</b>	<b>511-0360</b>	<b>19.00</b>	<b>511-0368</b>	<b>22.25</b>
P-20	HRC 50-55	P-20	<b>511-0355</b>	<b>15.85</b>	<b>511-0363</b>	<b>19.00</b>	<b>511-0371</b>	<b>22.25</b>
P-20 Modified	HRC 30-35	P-20 Modified	<b>511-0356</b>	<b>15.85</b>	<b>511-0364</b>	<b>19.00</b>	<b>511-0372</b>	<b>22.25</b>
NAK55	HRC 35	P-21	-	-	-	-	<b>511-0373</b>	<b>22.25</b>
S-7	HRC 54-56	S-7	<b>511-0354</b>	<b>15.85</b>	<b>511-0362</b>	<b>19.00</b>	<b>511-0370</b>	<b>22.25</b>
SS 316	HRC 20	SS 316	<b>511-0350</b>	<b>15.85</b>	<b>511-0358</b>	<b>19.00</b>	<b>511-0366</b>	<b>22.25</b>

## C Welding Wire – mm diameters

Available in two diameters: 0.3mm and 0.6mm. Measure 150mm (6") long. Sold in packages of 20.

Material	Hardness	Application	0.3 Dia. Item#	Pkg. of 20	0.6 Dia. Item#	Pkg. of 20
NAK80	HRC 38-40	P-20, P-21	<b>511-0379</b>	<b>\$31.75</b>	<b>511-0374</b>	<b>\$51.90</b>
NAK55	HRC 38-40	P-21	<b>511-0376</b>	<b>31.75</b>	<b>511-0375</b>	<b>51.90</b>
STAVAX	HRC 50-52	STAVAX	<b>511-0378</b>	<b>39.75</b>	<b>511-0377</b>	<b>69.90</b>

## D Welding Wire – mm diameters

Each package contains 5 meters (approx. 16.5') of wire. Available in four diameters: 0.2mm, 0.3mm, 0.4mm and 0.5mm.

Material	Hardness	Application	0.2mm Dia. Item#	0.3mm Dia. Item#	0.4mm Dia. Item#	0.5mm Dia. Item#	Each
SS Alloy	HRB 90	All Mold Steels	<b>511-0290</b>	<b>511-0291</b>	<b>511-0292</b>	<b>511-0293</b>	<b>\$15.75</b>



## A PUK 3 High-Precision Welding Systems

PUK 3 spot welders carry the technological advancements of previous-generation PUK units to a whole new level. Each creates 0.3–3.0mm diameter welding points with very low heat, allowing you to hold workpieces by hand for more control. Discharges a quick burst of argon gas around the electrode tip and work surface while welding to prevent oxidation, yielding smooth-as-silk welds with maximum homogeneity. Ideal for permanent welding and tack welding prior to soldering. Welding is simple: just touch the electrode tip to the work surface, take a couple seconds to position it where you want, and the weld is made. If repositioning is needed, simply lift the tip off the work surface to break contact.

These units boast modeled energy impulses with intelligent distribution for welding softly and prolonging electrode life. When fusing metals in tight areas, a special setting shortens impulse times to increase weld quality and strength. Micro mode helps with delicate tasks, enabling microwelding on sheet metal as thin as 0.10mm. Increased controller performance and gas preflow period that self-adjusts to working speed allow you to work twice as fast. PUK 3 Professional Plus offers all the benefits of PUK 3 Professional as well as more power, finer setting ranges and five program slots in which you can save frequently used settings. Both units include 10"W x 11"D x 6"H stainless steel controller, Mezzo Stereomicroscope (features precise, adjustable 10X optics with large viewing area for razor-sharp close-ups of work in progress, electronic eye filter for vision-field darkening, adjustable handpiece arm and integral 20W lighting unit), 5" long welding handpiece, 10 reversible electrode tips, cross-locking electrode tweezers, flat electrode pliers, electrode clamp, diamond disc for cleaning electrode tips, 10' gas hose and complete instructions. Electrical: 110V, 50/60Hz. Made in Germany according to stringent VDE guidelines. CE approved.

### Applications:

- Weld stainless steel, titanium, bronze, copper and tin alloys.
- Fill porosity in castings by adding the same type of metal.
- Weld different metals together without solder.
- Fix parts with tack welds prior to soldering.

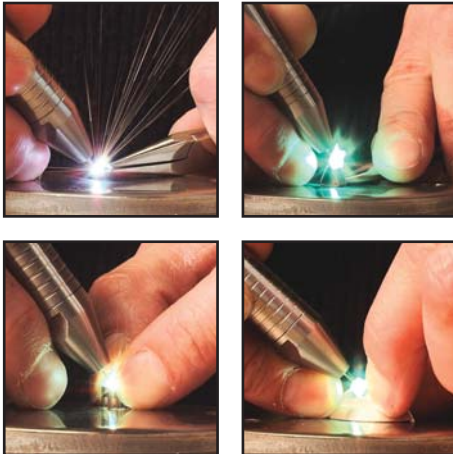

### Specifications:

	PUK 3 Professional Plus	PUK 3 Professional
Power Range	9–320A	10–240A
Power Settings	12 std., 10 micro	10 std., 10 micro
Impulse Range	4–30ms std., 4–12ms micro	4–24ms std., 4–8ms micro
Impulse Settings	9	5
Welding Speed	0.8 sec.	0.8 sec.
Inert Gas	Requires argon gas tank	Requires argon gas tank

Description	Item#	Each
A. PUK 3 Professional Plus	<b>830-0990</b>	<b>\$4,570.00</b>
PUK 3 Professional	<b>830-0995</b>	<b>3,995.00</b>
Optional Argon Gas Regulator	<b>830-0974</b>	<b>144.00</b>
Replacement Electrode Tips, set of 10	830-0978	39.70

## B Hydroflux Welder System

Hydroflux is a complete torch system that manufactures its own fuel from distilled water. Uses a hydrogen/oxygen mixture to produce noncontaminating flames with temperatures up to 4,850°F (2,675°C). Ideal for soldering and welding.

Includes torch with 4' flexible hose, eight hypodermic-type tips that create pinpoint to broad flames, chemicals, sight gauges for flux and water, in-line dryer and instructions for easy setup and operation. Measures 16"W x 9"D x 10"H. Ship. wt: 45 lbs. Made in USA.



Description	Item#	Each
Complete System, 110V	<b>830-0830</b>	<b>\$1,250.00</b>
Complete System, 220V	<b>830-0831</b>	<b>1,325.00</b>
System w/o chemicals, 220V	<b>830-0832</b>	<b>1,325.00</b>
Replacement Electrolyte Solution, 1 qt.	830-0833	30.50
Replacement Flux Solution, 1 qt.	830-0834	19.50
Replacement Torch with 4' hose	830-0835	108.50
Replacement 8-Piece Tip Set	830-0836	4.65
Replacement Cotton Fiber Filter	830-0837	5.55



### Little Torch™

The Little Torch welds with incredible precision an unlimited range of materials from less than 0.001" copper wire to 16-gauge steel with Oxy/Acetylene or Oxy/Hydrogen. It brazes the tiniest elements with uncanny accuracy. It solders hard or soft materials. Whether your material is metal, plastic, glass or even ceramic, Little Torch does the job quickly and easily.

Its rugged aluminum alloy body weighs only 0.5 oz. and is superbly balanced to allow the operator to maneuver easily in areas impossible to enter with a conventional tool. The pencil-style handle makes it easy to direct the flame exactly where you want it for a cleaner, more professional job. It features a thin, extremely lightweight hose that gives it added flexibility. Little Torch heats with infinite control at an infinite variety of settings and sizes. Produce thread-thin flames up to 6,300°F.

Can be used with many fuels, including acetylene, hydrogen, propane, propylene, MAPP, LP and natural gas. Six brazing tips available individually (see p. 280).

### A, B Little Torch™ Deluxe Sets

Each Little Torch Deluxe Set includes one torch handpiece, five brazing tips, 6' oxygen and 6' fuel gas twin hose with 1/16" connectors, two single-stage regulators (one for oxygen, one for fuel gas), one oxygen tank, one fuel gas tank and a carrier. (Tanks shipped empty.)

Description	Item#	Set
A. For Oxy/Acetylene	<b>830-1020</b>	<b>\$687.00</b>
B. For Oxy/Propane	<b>830-1018</b>	<b>630.00</b>

### C Little Torch™ Sets

Each Little Torch Set includes one torch handpiece, 6' oxygen and 6' fuel gas twin hose with 1/16" connectors and five brazing tips. Medium sets also include two single-stage regulators (one for oxygen and one for fuel gas).

Description	Item#	Set
C. Medium Set for Oxy/Acetylene	<b>830-1010</b>	<b>\$325.00</b>
Medium Set for Oxy/Propane	<b>830-1015</b>	<b>325.00</b>
Starter Set for Oxy/Acetylene or Hydrogen	<b>830-1000</b>	<b>109.00</b>
Starter Set for Oxy/Propane or Natural Gas	<b>830-1002</b>	<b>109.00</b>

### D - G Little Torch™ Regulators

Compact regulators for single torch use. Provide accurate control of oxygen and acetylene or propane for welding, soldering, brazing and heating operations. Maintain uniform pressure and contain protective check valves. Include easy-turning T-bars.

Description	Item#	Each
D. For Oxygen	<b>830-1021</b>	<b>\$115.65</b>
E. For Acetylene MC Tank	<b>830-1022</b>	<b>109.65</b>
F. For Propane	<b>830-1023</b>	<b>115.65</b>
G. For Acetylene B Tank	<b>830-1024</b>	<b>115.65</b>
For Hydrogen (not shown)	<b>830-1016</b>	<b>99.90</b>

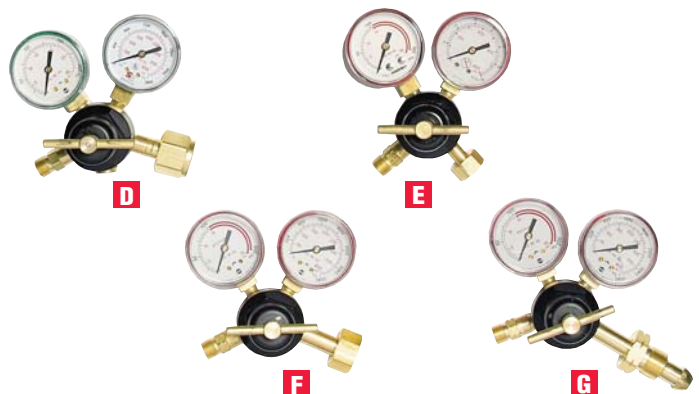





## A Little Torch™ Brazing Tips

Because of their extraordinarily small orifices, tips 2 and 3 are fitted with synthetic sapphires to ensure accurate performance and control. Tip 2 is for oxy/acetylene only.

Tip Size	Gas Pressures (PSI)		Flame Temps. (°F)			Item#	EACH Prices	
	Oxygen	Fuel Gas	Acet.	Prop.	NG		1-2	3+
2	2	2	6,000	—	—	<b>830-1102*</b>	<b>\$21.50</b>	<b>\$19.35</b>
3	4	4	6,000	3,000	4,200	<b>830-1103</b>	<b>21.50</b>	<b>19.35</b>
4	4	4	6,000	3,000	4,200	<b>830-1104</b>	<b>21.50</b>	<b>19.35</b>
5	6	6	6,000	3,000	4,200	<b>830-1105</b>	<b>21.50</b>	<b>19.35</b>
6	6	6	6,000	3,000	4,200	<b>830-1106</b>	<b>21.50</b>	<b>19.35</b>
7	8	8	6,000	3,000	4,200	<b>830-1107</b>	<b>21.50</b>	<b>19.35</b>

Flame drawings are symbolic representations of neutral settings for each tip. Each tip has a variety of settings for particular needs.  
\*For oxygen and acetylene only.

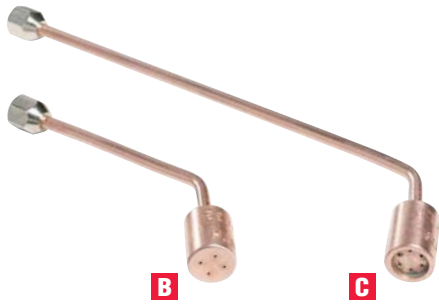

## B, C Little Torch™ Heating Tips

For work requiring large amounts of heat. Specially designed with four orifices to produce four flames that combine into one flame. Each of the four orifices is equal to tip 4 in size.

Description	Length	Item#	EACH Prices	
			1-2	3+
<b>B.</b> For Oxy/Acetylene	3"	<b>830-1115</b>	<b>\$35.60</b>	<b>\$32.04</b>
<b>C.</b> For Oxy/Propane and Oxy/Nat. Gas	6"	<b>830-1116</b>	<b>42.80</b>	<b>38.52</b>

Max. temperatures: 3,600°F for propane and 6,000°F for all other fuels.



## D - F Torch Lighters

Electric Torch Mate allows you to light any torch easily with one hand. Just rest your torch on Torch Mate's ignition switch, and a small spark from the electrode immediately lights the torch. Includes two AA batteries.

Flint Lighter produces a spark by friction to light any torch safely without an open flame. Includes one flint.

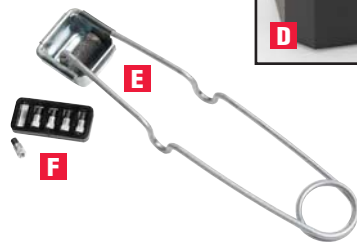

Description	Item#	Each
<b>D.</b> Electric Torch Mate	<b>830-0407</b>	<b>\$32.50</b>
<b>E.</b> Flint Lighter	<b>830-0410</b>	<b>3.85</b>
<b>F.</b> Replacement Flints, pkg. of 5	830-0411	3.35



## G, H Little Torch™ Holders

Cradle Holder keeps your Little Torch at the ideal angle for easy, safe use. Features sturdy cast base, heavy-duty 4mm steel rod and holes for storing extra tips. Made in USA.

Magnetic Holder lets you quickly and easily position your Little Torch. Features 2¾" dia. weighted base, extra-thick steel rod, powerful magnet for securing your torch and holes for storing extra tips. Measures 4½" high.

Description	Item#	Each
<b>G.</b> Cradle Holder	<b>830-1307</b>	<b>\$11.75</b>
<b>H.</b> Magnetic Holder	<b>830-1250</b>	<b>35.10</b>

### The Small Torch™ by Gentec

This lightweight, durable torch features user-friendly control knobs for quick, precise, one-handed flame adjustments and nickel-plated brass handle with stainless steel inner gas tubes for superior strength. Designed specifically for brazing and soldering at the bench as well as melting small amounts of metal. Provides stable, concentrated feather flames up to 6,000°F. Choose from basic and complete kits. Compatible with accessories listed below and other popular brands of accessories. Backed by a two-year manufacturer's limited warranty.

**Features:**

- Lightweight, durable design for comfort and longevity.
- User-friendly control knobs for convenient one-handed operation.
- Accepts standard tips for soldering and brazing and rosebud tips for melting.
- Fully compatible with other popular brands of accessories.
- Backed by two-year manufacturer's limited warranty.

#### A The Small Torch™ Complete Caddy Kits

Each includes The Small Torch handle, five tips, 12' dual oxygen and fuel hose with "B" (3/16") fittings, oxygen and fuel regulators, tank(s) and handy plastic carrying caddy. Oxy/Propane Kit includes #3, 4, 5, 6 and 7 tips and oxygen tank (only for use with disposable propane tanks); Oxy/Acetylene Kit includes #2, 3, 4, 5 and 6 tips and oxygen and acetylene tanks. Tanks shipped empty. Net wt: 30 lbs.

Description	Item#	Each
A. Oxy/Propane Kit	<b>830-1603</b>	<b>\$299.00</b>
Oxy/Acetylene Kit	<b>830-1604</b>	<b>399.00</b>

#### B The Small Torch™ Basic Kits

Each includes The Small Torch handle, five tips, 12' dual oxygen and fuel hose with "B" (3/16") fittings and adapter for "A" (3/8") fittings. Oxy/Propane Kit includes #3, 4, 5, 6 and 7 tips; Oxy/Acetylene Kit includes #2, 3, 4, 5 and 6 tips. Optional melting tips are 6" long, multi-orifice rosebud tips for melting up to 3 oz. of gold, silver or bronze.

Description	Item#	Each
B. Oxy/Propane Kit	<b>830-1600</b>	<b>\$82.49</b>
Oxy/Acetylene Kit	<b>830-1601</b>	<b>82.49</b>
#2 Tip (oxy/acetylene use only)	<b>830-1614</b>	<b>14.99</b>
#3 Tip	<b>830-1615</b>	<b>14.99</b>
#4 Tip	<b>830-1616</b>	<b>14.99</b>
#5 Tip	<b>830-1617</b>	<b>14.99</b>
#6 Tip	<b>830-1618</b>	<b>14.99</b>
#7 Tip	<b>830-1619</b>	<b>14.99</b>
Twin #3 Tip	<b>830-1620</b>	<b>22.90</b>
Propane Rosebud Melting Tip	<b>830-1612</b>	<b>20.75</b>
Acetylene Rosebud Melting Tip	<b>830-1613</b>	<b>20.75</b>

#### C - E The Small Torch™ Regulators

Single-stage regulators manufactured using state-of-the-art equipment. Feature chrome-plated housing caps and bodies machined from class "A" brass bar stock. Single-stage, rear-entry design ensures safe, neat fit in caddy systems. Internal safety pressure relief valve and stem-type seat assembly promote reliable seating.

Description	Item#	Each
Oxygen Regulator	<b>830-1607</b>	<b>\$63.35</b>
Propane Regulator	<b>830-1608</b>	<b>59.10</b>
C. Acetylene Regulator	<b>830-1609</b>	<b>59.10</b>
D. Oxygen Regulator for Disposable Tanks	<b>830-1610</b>	<b>31.10</b>
E. Fuel Gas Regulator for Disposable Tanks	<b>830-1611</b>	<b>31.10</b>

#### F, G Gentec Casting Torch

Casting torch for use with oxygen/propane or oxygen/natural gas. Features a high-quality forged brass handle with "tube-in-a-tube" design for high strength. Combine with Heating Tip to create a versatile casting, soldering and melting torch. Handle measures 6" long.

Description	Item#	Each
F. Casting Torch Handle only	<b>830-1621</b>	<b>\$74.35</b>
G. #6 Heating Tip with Tube	<b>830-1622</b>	<b>33.38</b>

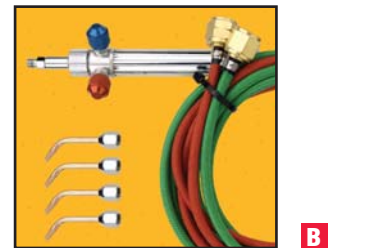



**A**



**A Gesswein® Sweep Ultrasonics**

Sweep Ultrasonic Cleaners feature a brushed steel housing with stainless steel tank and lid, on/off switch, 30 minute timer with hold function, drain, heater and EMI (electromagnetic interference) filter. Instead of having a fixed kilohertz output like most other ultrasonic cleaners, Sweep Ultrasonics are designed to cycle regularly through a kilohertz range. They generate tightly packed layers of ultrasonic waves throughout their tanks for more powerful, faster cleaning action. Ultrasonic waves are fully and evenly distributed, regardless of cleaning load and solution level. Cavitation reaches into all corners of the tanks, leaving no weak zones or “hot spots.” Engineered for heavy-duty, full-time use. Both units 50/60Hz.

110V Model	Sonic Power (W)	Dimensions (W x D x H) Overall		Item#	Each
.84 gal.	150	10 <sup>3</sup> / <sub>8</sub> " x 6 <sup>3</sup> / <sub>8</sub> " x 8"	9 <sup>3</sup> / <sub>8</sub> " x 5 <sup>3</sup> / <sub>8</sub> " x 4"	<b>851-5046</b>	<b>\$495.00</b>
2.75 gal.	510	12 <sup>5</sup> / <sub>8</sub> " x 10 <sup>3</sup> / <sub>8</sub> " x 11 <sup>1</sup> / <sub>8</sub> "	11 <sup>3</sup> / <sub>4</sub> " x 9 <sup>3</sup> / <sub>8</sub> " x 6"	<b>851-5048</b>	<b>1,080.00</b>
Replacement				Item#	Each
Drain Fitting and Hose Assembly, 3/8" dia.				851-5145	\$18.44
Heater Switch for Model .84				851-5054	6.50
Heater Switch for Model 2.75				851-5055	21.65
Timer Assembly				851-5052	32.50
Timer knob				851-5053	4.00

Accessories	Dimensions (L x W x D)	For Model	Item #	Each
Mesh Baskets	5 <sup>3</sup> / <sub>8</sub> " x 5" x 3 <sup>1</sup> / <sub>4</sub> "	.84	<b>851-5101</b>	<b>\$36.99</b>
	9" x 5" x 3 <sup>3</sup> / <sub>8</sub> "	.84, 2.75	<b>851-5121</b>	<b>39.99</b>
	11" x 5 <sup>3</sup> / <sub>8</sub> " x 5 <sup>1</sup> / <sub>4</sub> "	2.75	<b>851-5126</b>	<b>68.00</b>
Solid Wall Baskets	8 <sup>3</sup> / <sub>8</sub> " x 4 <sup>1</sup> / <sub>2</sub> " x 3"	.84, 2.75	<b>851-5110</b>	<b>92.00</b>
Auxiliary Pans	9 <sup>1</sup> / <sub>4</sub> " x 5 <sup>1</sup> / <sub>4</sub> " x 2 <sup>3</sup> / <sub>4</sub> "	.84	<b>851-5170</b>	<b>99.50</b>
	11 <sup>1</sup> / <sub>2</sub> " x 5 <sup>3</sup> / <sub>4</sub> " x 3"	2.75	<b>851-5175</b>	<b>120.00</b>

**B L&R Quantrex® Ultrasonic Cleaners**

Made by L&R, a leader in ultrasonic cleaning technology, Quantrex Ultrasonic Cleaners feature durable vinyl-clad steel housings, stainless steel tanks and lids, 60-minute timers and drains (except Model 90, which has a timer but no drain), EMI (electromagnetic interference) filters for worry-free operation around all other electronic equipment within your work area, premium system components and contemporary design. Include integral heating elements at a preset temperature of approx. 160°F. Provide quiet yet strong 43kHz cleaning action. Backed by a 2<sup>1</sup>/<sub>2</sub> year manufacturer's warranty—the most comprehensive in the industry.



**B**



110V Model	Capacity (qts.)	Dimensions (W x D x H) Overall		Item#	Each
90	2	7" x 6 <sup>3</sup> / <sub>8</sub> " x 8 <sup>3</sup> / <sub>4</sub> "	5 <sup>7</sup> / <sub>8</sub> " x 5 <sup>3</sup> / <sub>8</sub> " x 4"	<b>851-5070</b>	<b>\$269.00</b>
140	3 <sup>3</sup> / <sub>8</sub>	10 <sup>1</sup> / <sub>4</sub> " x 6 <sup>1</sup> / <sub>2</sub> " x 8 <sup>1</sup> / <sub>4</sub> "	9 <sup>3</sup> / <sub>8</sub> " x 5 <sup>3</sup> / <sub>8</sub> " x 4"	<b>851-5072</b>	<b>410.00</b>
210	6	12 <sup>3</sup> / <sub>4</sub> " x 7" x 11"	11 <sup>3</sup> / <sub>4</sub> " x 6" x 6"	<b>851-5074</b>	<b>695.00</b>
310	13	16 <sup>1</sup> / <sub>2</sub> " x 10" x 12"	15 <sup>1</sup> / <sub>2</sub> " x 9" x 6"	<b>851-5076</b>	<b>1,475.00</b>
650	26	21 <sup>3</sup> / <sub>4</sub> " x 14" x 12 <sup>1</sup> / <sub>2</sub> "	19 <sup>3</sup> / <sub>4</sub> " x 4 <sup>3</sup> / <sub>4</sub> " x 6 <sup>1</sup> / <sub>2</sub> "	<b>851-5077</b>	<b>1,525.00</b>
220V Model	Capacity (qts.)	Dimensions (W x D x H) Overall		Item#	Each
90	2	7" x 6 <sup>3</sup> / <sub>8</sub> " x 8 <sup>3</sup> / <sub>4</sub> "	5 <sup>7</sup> / <sub>8</sub> " x 5 <sup>3</sup> / <sub>8</sub> " x 4"	<b>851-5071</b>	<b>\$315.00</b>
140	3 <sup>3</sup> / <sub>8</sub>	10 <sup>1</sup> / <sub>4</sub> " x 6 <sup>1</sup> / <sub>2</sub> " x 8 <sup>1</sup> / <sub>4</sub> "	9 <sup>3</sup> / <sub>8</sub> " x 5 <sup>3</sup> / <sub>8</sub> " x 4"	<b>851-5073</b>	<b>455.00</b>
210	6	12 <sup>3</sup> / <sub>4</sub> " x 7" x 11"	11 <sup>3</sup> / <sub>4</sub> " x 6" x 6"	<b>851-5075</b>	<b>855.00</b>
310	13	16 <sup>1</sup> / <sub>2</sub> " x 10" x 12"	15 <sup>1</sup> / <sub>2</sub> " x 9" x 6"	<b>851-5078</b>	<b>2,050.00</b>
650	26	21 <sup>3</sup> / <sub>4</sub> " x 14" x 12 <sup>1</sup> / <sub>2</sub> "	19 <sup>3</sup> / <sub>4</sub> " x 4 <sup>3</sup> / <sub>4</sub> " x 6 <sup>1</sup> / <sub>2</sub> "	<b>851-5079</b>	<b>2,095.00</b>

Accessories	Dimensions (L x W x D)	For Model	Item #	Each
Mesh Baskets	5 <sup>3</sup> / <sub>8</sub> " x 5" x 3 <sup>1</sup> / <sub>4</sub> "	90, 140, 210	<b>851-5101</b>	<b>\$36.99</b>
	9" x 5" x 3 <sup>3</sup> / <sub>8</sub> "	140	<b>851-5121</b>	<b>39.99</b>
	11" x 5 <sup>3</sup> / <sub>8</sub> " x 5 <sup>1</sup> / <sub>4</sub> "	210	<b>851-5126</b>	<b>68.00</b>
Solid Wall Baskets	5" x 4 <sup>1</sup> / <sub>2</sub> " x 2 <sup>3</sup> / <sub>4</sub> "	90, 140, 210	<b>851-5100</b>	<b>78.00</b>
	8 <sup>3</sup> / <sub>8</sub> " x 4 <sup>1</sup> / <sub>2</sub> " x 3"	140	<b>851-5110</b>	<b>92.00</b>
Auxiliary Pans	9 <sup>1</sup> / <sub>4</sub> " x 5 <sup>1</sup> / <sub>4</sub> " x 2 <sup>3</sup> / <sub>4</sub> "	140	<b>851-5170</b>	<b>99.50</b>
	11 <sup>1</sup> / <sub>2</sub> " x 5 <sup>3</sup> / <sub>4</sub> " x 3"	210	<b>851-5175</b>	<b>120.00</b>

**A Elma SX30H Ultrasonic Cleaner**

With its microprocessor control and many user-friendly features, this professional-grade unit runs 30% more efficiently than Elma's economy unit. Features a built-in heater with LED display that shows both set and actual temperatures from 30–80°C (88–175°F). Includes heavy-duty plastic lid that helps reduce noise and also doubles as a drip tray, as well as a free sample of ultrasonic cleaning solution. Capacity: 2.75L (approx. 3 quarts). Electrical: 110–120V, 50/60Hz. Weighs 7¼ lbs. CE approved. Made in Germany. *Note: Has no drain; just lift and pour to remove water.*

**Features:**

- 30-minute electronic timer with continuous-on setting option
- LED display of set and remaining cleaning time
- 37kHz high-performance transducers
- Stainless steel tank and housing
- Automatic sweep function for full tank cleaning
- Nonsweep option for concentrated energy
- Dry-run protection for heater
- Auto de-gas for new bath in just 10 minutes
- Splash-proof membrane keypad for easy cleanup
- Fill level clearly marked on tank

Model	Dimensions (W x D x H)		Item#	Each
	Overall	Tank		
SX30H	12"w x 7"d x 8¾"h	9½"w x 5¾"d x 4"h	<b>851-4203</b>	<b>\$499.50</b>
Accessories	Dimensions (L x W x D)		Item#	Each
Mesh Baskets	5¾" x 5" x 3¼"	SX30H	<b>851-5101</b>	<b>\$36.99</b>
	9" x 5" x 3¾"	SX30H	<b>851-5121</b>	<b>39.99</b>



**A**



**B Digisonic Ultrasonic Cleaner**

Removes the most stubborn dirt and polishing compounds from jewelry. Provides 42kHz of cleaning power. Features quiet solid-state circuitry; advanced digital controls with 90-, 180-, 280-, 380- and 480-second cleaning cycles; isolated electronics for protection against moisture and leaks; heavy-duty wipe-clean plastic housing and stainless steel tank; and automatic shutoff for safety. Includes lid with viewing window, jewelry cleaning basket and free sample of ultrasonic cleaning solution. Capacity: 1½ quarts. Electrical: 100–120V, 60W, 60Hz. Measures 9"W x 7"D x 6¼"H. CE, GS, PSE, CETL and ETL approved. Conforms to UL Std. 1431.

Description	Item#	EACH Prices	
		1-5	6+
Digisonic Ultrasonic Cleaner	<b>851-4905</b>	<b>\$73.95</b>	<b>\$66.56</b>



**B**

**C Sonic Wave Ultrasonic Cleaner**

This compact ultrasonic provides 35 watts and 42,000 cycles of cleaning power. Features quiet solid-state circuitry, high-impact plastic body, attached see-through lid, one-piece stainless steel tank, three-minute timer with auto-shutoff and neon blue power light. Includes cleaning basket, free sample of ultrasonic cleaning solution and instructions. Capacity: ½ quart. Electrical: 110V, 50/60Hz. Measures 7¾"W x 5"D x 5"H. Backed by a one-year manufacturer's warranty. ETL listed and CE approved.

Description	Item#	EACH Prices	
		1-5	6+
Sonic Wave Ultrasonic Cleaner	<b>851-4901</b>	<b>\$33.95</b>	<b>\$28.86</b>



**C**





**A, B Gesswein® Ultrasonic Cleaning Solution**  
**Comes in super-concentrated form for exceptional value!**

Improves performance of your ultrasonic cleaner, reducing cleaning time. Cleans without using harsh chemicals that can damage your ultrasonic tank, such as ammonia. In fact, it inhibits rust, so it actually helps protect your parts and tank. Contains no phosphates, which thicken with use and shorten solution life. Gives you a long-lasting supply for your money at 40:1 concentration. Won't irritate eyes or nose. Complies with water treatment regulations for direct disposal into sewage. Meets OSHA standards.

Description	Item#	EACH Prices	
		1-5	6+
<b>A.</b> 1-quart Bottle	<b>851-5300</b>	<b>\$23.60</b>	<b>\$18.88</b>
1-gallon Bottle	<b>851-5308</b>	<b>81.00</b>	—
<b>B.</b> 5-gallon Pail	<b>851-5305</b>	<b>290.00</b>	—

*Ask for bulk pricing.*



**C BCR Plus Cleaner – Extra-strong buffing compound remover.**

Ideal for your toughest cleaning jobs. Works effectively on steel, stainless steel, zinc, magnesium, brass, copper and aluminum. Concentrated: use 3–20% by volume depending on extent of compound buildup. Exceptional rinsability eliminates hand wiping, streaking and discoloration.

Description	Item#	Each
<b>C.</b> 1-gallon Bottle	<b>812-0670</b>	<b>\$24.50</b>
5-gallon Pail	<b>812-0675</b>	<b>81.95</b>
15-gallon Drum	<b>812-0680</b>	<b>247.95</b>
51-gallon Drum	<b>812-0685</b>	<b>695.00</b>



**D Supra Galvex Swiss Formula Ultrasonic Cleaning Solution**  
**One of the most effective cleaners you'll ever use!**

Swiss Formula Supra Galvex ensures fast, thorough cleaning of brass, stainless steel, titanium, zinc and more. This nonoxidizing polishing compound remover is free of complexing agents (EDTA), silicates, phosphates and alkaline hydroxides. Concentrated: use 50:1 in tap water, 100:1 in distilled or deionized water. Made in Switzerland.

Description	Makes up to	Item#	EACH Prices	
			1-5	6+
1-pint Bottle	50 qts.	<b>851-5301</b>	<b>\$15.85</b>	—
1-quart Bottle	100 qts.	<b>851-5302</b>	<b>24.50</b>	<b>\$19.60</b>
1-gallon Bottle	100 gals.	<b>851-5307</b>	<b>66.00</b>	—
5-gallon Pail	500 gals.	<b>851-5304</b>	<b>325.00</b>	—



**E OrganiClean® Organic-Based Ultrasonic Soap Concentrate**

A very effective yet safe concentrate for fast removal of polishing compounds, finger grease and other soils. Gentle on your hands due to neutral pH of 7 and organic-based formulation. Use a water:concentrate mixing ratio of 128:1 to 40:1 for fast results. Pleasant, mild aroma.

Description	Yield at 40:1	Item#	Each
1-quart. Bottle	10 gallons	<b>851-5363</b>	<b>\$19.50</b>
1-gallon Bottle	40 gallons	<b>851-5362</b>	<b>66.00</b>
5-gallon Pail	200 gallons	<b>851-5361</b>	<b>260.00</b>



**F Drum Pump – For 5-, 15-, 30- and 51-gallon drums.**

A reusable plastic pump for easily dispensing cleaning solution from any standard drum. Lets you take advantage of bulk pricing without having to worry about lifting or tilting heavy, awkward containers. Features raised spout that dispenses liquid at a convenient working height. Includes adapters and extension tubing for standard 5-, 15-, 30- and 51-gallon drums. Adjusts to dispense exact quantities of 4, 8, 12 or 16 av. oz.

Description	Item#	Each
Drum Pump	<b>852-0942</b>	<b>\$69.00</b>



**A Deluxe Junior Steamer**

This compact tabletop unit boasts up to 40% greater effective capacity than similar ones, so it provides more steam before needing a water refill. Features a high-limit control switch that regulates heat and pressure automatically (much more reliable than a thermostat and one of the updated safety requirements mandated by ASME CSD-1), as well as an improved sight gauge for easier viewing and replacement. Made of toughest materials to withstand everyday use. Easy to install with no plumbing required.

Includes operating pressure control switch for easy adjustment, fast heating element for responsive on-demand steam generation, foot-controlled solenoid switch, low-water cutoff reset switch, steam pressure gauge, safety relief valve, lockable blowdown drain valve and inlet funnel and valve. Chamber size: 0.26 cu. ft. Water capacity: 1.5 gals. Max. pressure: 60–85 PSI. Electrical: 120V, 13A, 1500W, 50/60Hz. Measures 14½"W x 14½"D x 18½"H. Backed by a one-year limited warranty. ASME certified. UL and CSA approved.

Description	Item#	Each
Deluxe Junior Steamer	<b>853-0059</b>	<b>\$970.00</b>



**B Steam Cleaner Powder – For boiler-style steamers.**

For removing rust and mineral deposits from boiler chamber of steam cleaner. Comes in 4 oz. bottle sufficient for one cleaning, which should be done once a week.

Description	Item#	EACH Prices		
		1-2	3-9	10+
Steam Cleaner Powder	<b>853-1000</b>	<b>\$5.95</b>	<b>\$4.76</b>	<b>\$4.17</b>



**C Cyclone Steamer**

Instead of a pressurized boiler, this highly efficient steamer uses a heating chamber to instantly flash incoming water into steam, so it needs no boiler permits. Safe and quiet enough for stores and offices. Warms up in 5–10 minutes, then delivers continuous dry steam for up to 1½ minutes—impressive for such a compact unit. Features high-limit temperature shutoff with automatic reset, foot controller, durable stainless steel front panel and off-white finished housing. Max. pressure: 60 PSI. Electrical: 120V, 12.5A, 1500W. Measures 8¼"W x 9¾"D x 8¼"H. Requires distilled water. UL listed.

Description	Item#	Each
Cyclone Steamer	<b>853-0066</b>	<b>\$695.00</b>



**D, E Jewel Jet Steam Cleaners**

Compact steam cleaners for use almost anywhere. Choose from two models: Mini and Pro. Each produces a powerful blast of steam that removes stubborn dirt. Heats up in only a few minutes, so it can be turned on right when needed. Uses ordinary tap water and requires no chemicals. Includes fill cup, funnel, stainless steel mesh basket and tweezers. Pro also includes foot pedal for hands-free operation and automatic lock button to keep steam flowing. Backed by a one-year manufacturer's warranty. UL listed. *Please note: Neither model is designed to replace a heavy-duty commercial steamer.*

Specifications:	Mini	Pro
Capacity	½ pint	1 liter
Operating Pressure	25 PSI (approx.)	50 PSI (approx.)
Electrical	110V, 1000W, 60Hz	120V, 1450W, 60Hz
Dimensions	6"W x 7"D x 9½"H	9½"W x 12"D x 14"H

Description	Item#	EACH Prices	
		1-5	6+
<b>D.</b> Jewel Jet Mini Steam Cleaner	<b>853-0068</b>	<b>\$55.00</b>	<b>\$52.25</b>
<b>E.</b> Jewel Jet Pro Steam Cleaner	<b>853-0076</b>	<b>250.00</b>	–





**A**

**B**



**D**

**E**



**F**

**G**



**H**

**I**



**J**

**A Sprints Mold Release Spray**

Net wt: 12 fl. oz.

Description	Item#	Each
Mold Release Spray	<b>816-2925</b>	<b>\$8.30</b>

**B Sprints Citrus Mold Cleaner**

A great general-purpose cleaner for removing release agents, greases, oils, fingerprints and other contaminants from molds, tools and machines. Biodegradable. Net wt: 12 fl. oz.

Description	Item#	EACH Prices	
		1-11	12+
Citrus Mold Cleaner	<b>816-2932</b>	<b>\$6.70</b>	<b>\$6.37</b>

**C Sprints Mold Cleaner/Degreaser**

A powerful all-purpose cleaner and degreaser for molds, tools and machines. Ideal for post-run use. Nonflammable. Net wt: 20 fl. oz.

Description	Item#	EACH Prices	
		1-11	12+
Mold Cleaner/Degreaser	<b>816-2933</b>	<b>\$5.95</b>	<b>\$5.65</b>

**D Sprints Hi-Purity Mold Cleaner**

Contains an odorless solvent that removes release agents, greases and oils from molds, tools and machines. FDA regulated. Net wt: 12 fl. oz.

Description	Item#	EACH Prices	
		1-11	12+
Hi-Purity Mold Cleaner	<b>816-2935</b>	<b>\$5.95</b>	<b>\$5.65</b>

**E Sprints Mold Protectant**

Contains three components that neutralize fingerprints, condensation and corrosion on molds, tools and machines. Helps safeguard all metals. Use one light coat to protect for a few weeks, two light coats to protect for a year. Net wt: 12 fl. oz.

Description	Item#	EACH Prices	
		1-11	12+
Mold Protectant	<b>816-2934</b>	<b>\$5.95</b>	<b>\$5.65</b>

**F, G Metal Cleaner/Degreaser**

Water-based alkaline cleaner for removing grease, oil, carbon and other contaminants from metal finishing systems. Cleans without foaming, making it effective for jet-spray, immersion, ultrasonic and manual applications. Nonhazardous, nontoxic and biodegradable. Requires no special handling or storage. Comes in concentrated form.

Description	Item#	Each
<b>F.</b> 1-quart Bottle	<b>825-1403</b>	<b>\$8.50</b>
<b>G.</b> 1-gallon Bottle	<b>825-1404</b>	<b>19.95</b>

**H, I Aluminum Cleaner**

Powerful formula for cleaning aluminum, aluminum alloys, brass, copper, stainless steel and high-alloy steels. Contains rust inhibitor for exceptional rust protection. Nonhazardous, nontoxic and biodegradable. Requires no special handling or storage. Comes in concentrated form.

Description	Item#	Each
<b>H.</b> 1 qt. Bottle	<b>825-1400</b>	<b>\$6.95</b>
<b>I.</b> 1 gal. Bottle	<b>825-1401</b>	<b>16.70</b>

**J ESP Anti-Rust Spray**

Protects all metal surfaces from rust and corrosion after cleaning. Neutralizes fingerprints and displaces water. No CFCs. Net wt: 16 fl. oz.

Description	Item#	EACH Prices	
		1-11	12+
ESP Anti-Rust Spray	<b>825-1450</b>	<b>\$13.95</b>	<b>\$12.56</b>

**A 3M™ High Performance Cloth**

This amazing cloth has oil- and water-absorbing fibers that lift and trap both liquid and solid contaminants. Features a specially knitted design that does a better job of cleaning surfaces than conventional wipes. Can be used dry or damp. Removes grease, silicone, solvents, abrasive residues, polishes, waxes and fingerprints. Leaves no smears or streaks and is resistant to common cleaning chemicals. Can be machine-washed in temperatures up to 200°F. Measure 12¾" x 14". Comes in five different colors for easy coding to specific uses.

Description	Item#	EACH Prices	
		1-9	10+
White	<b>820-0500</b>	<b>\$5.50</b>	<b>\$4.40</b>
Blue	<b>820-0505</b>	<b>5.50</b>	<b>4.40</b>
Green	<b>820-0507</b>	<b>5.50</b>	<b>4.40</b>
Yellow	<b>820-0509</b>	<b>5.50</b>	<b>4.40</b>
Red	<b>820-0511</b>	<b>5.50</b>	<b>4.40</b>



**A**

**B SELVYT® Professional Cloth**

Features low nap and tight weave, same as Original Selvyt. Lifts off dust, smudges, dirt and fingerprints. Designed for finest polishing applications, including optical use on plastic and glass lenses. Made of woven unbleached cotton velvet. Stays lint-free after repeated washing. Stitched edges prevent fraying. Machine washable.

Description	Item#	EACH Prices	
		1-11	12+
10" x 10"	<b>820-0270</b>	<b>\$7.75</b>	<b>\$6.98</b>
14" x 14"	<b>820-0275</b>	<b>10.15</b>	<b>9.14</b>



**B**

**C Selvyt SR Cloth**

Made of pure unbleached cotton. Features no-lint texture that polishes without scratching. Retains its suppleness even after repeated washings.

Description	Size	Item#	EACH Prices	
			1-11	12+
Small Cloth	5" x 5"	<b>820-0100</b>	<b>\$2.25</b>	<b>\$1.87</b>
Medium Cloth	10" x 10"	<b>820-0155</b>	<b>6.25</b>	<b>5.44</b>
Large Cloth	14" x 14"	<b>820-0205</b>	<b>7.95</b>	<b>6.92</b>



**C**

**D Gesswein® Royal Gem Cloth**

Incredibly soft microfiber cloth. Removes dust and fingerprints quickly and easily. Contains no abrasives or chemicals. Leaves no residue behind. Stays lint-free after repeated washing. Stitched edges prevent fraying. Machine washable.

Description	Color	Item#	EACH Prices	
			1-11	12+
10" x 10"	Ivory	<b>820-0415</b>	<b>\$5.65</b>	<b>\$4.71</b>
	Lt. blue	<b>820-0419</b>	<b>5.65</b>	<b>4.71</b>



**D**



**A**

**A GLOVE-COTE 720® Protective Skin Lotion**

Features water-resistant formulation with protectants that guard skin particularly well against water-based irritants such as cooling lubricants and cutting fluids, as well as grime, grease and other irritants that can harm and stain. Apply before working to form an invisible shield that lasts for hours. Won't block pores or prevent perspiration. Contains moisturizers and emollients to prevent drying and cracking. Removes easily with soap and water. Silicone-free. Nontoxic. Made in USA.

Description	Item#	Each
6 oz. Tube	<b>805-1080</b>	<b>\$9.95</b>
1 qt. Bottle	<b>805-1090</b>	<b>44.95</b>



**B**

**B MAN-O® Protective Skin Cream**

Features unique formulation with solvent, insoluble protectants that guard skin against the toughest solvents, grime and grease, as well as other irritants that can harm and stain. Apply before working to form an invisible shield that lasts for hours. Won't block pores or prevent perspiration. Contains lanolin and glycerin to prevent drying and cracking. Removes easily with soap and water. Silicone-free. Nontoxic. Made in USA.

Description	Item#	Each
1 lb. Tub	<b>805-1085</b>	<b>\$9.95</b>



**C**

**C PR-88 Hand Protectant**

This glycerine-based compound prevents grease and grime from penetrating your skin. Apply before working to form an invisible shield that lasts for hours. Removes easily with soap and water.

Description	Item#	Each
3.5 oz. Tin	<b>812-0490</b>	<b>\$7.95</b>



**D**

**D MicroFlex® NeoPro® EC Glove – Ideal for rhodium plating!**

Exceptional comfort in a tough synthetic glove. NeoPro EC offers the barrier protection of a synthetic with the comfort, fit and feel of natural rubber latex. Offers 90% more puncture resistance than natural rubber latex. Resists a broad range of chemicals. Ideal for rhodium plating, electrocleaning and most other plating operations. Textured fingertips provide a secure grip. Extended, beaded cuff guards against splashes and spills. Made of polychloroprene, the generic name for neoprene. Ambidextrous. Powder-free and polymer-coated for easy donning. Length: 300mm (11.8"). Thicknesses: 8.3mil finger, 6.3mil palm, 4.7mil cuff. Color: green. Sold in dispenser box of 50.

Description	Item#	Box of 50
Small	<b>805-1052</b>	<b>\$17.50</b>
Medium	<b>805-1051</b>	<b>17.50</b>
Large	<b>805-1050</b>	<b>17.50</b>



**E**

**E MicroFlex® UltraSense™ Powder-Free Nitrile Glove – The alternative to latex!**

Powder-free UltraSense is a breakthrough in nitrile technology, providing the fit and feel of latex while eliminating the possibility of natural rubber latex allergic reaction. Provides reliable barrier protection against many hazardous and infectious substances. Highly elastic for easy conformance and reduced fatigue. Textured fingertips offer excellent grip in wet or dry conditions. Ambidextrous. Beaded cuff. Polymer-coated for easy donning. Length: 245mm (9<sup>7</sup>/<sub>8</sub>"). Thicknesses: 5.1mil finger, 3.5mil palm. Color: blue. Sold in dispenser box of 100.

Description	Item#	Box of 100
Small	<b>805-1072</b>	<b>\$14.75</b>
Medium	<b>805-1071</b>	<b>14.75</b>
Large	<b>805-1070</b>	<b>14.75</b>



**F**

**F Latex Gloves**

Disposable latex gloves for everyday use. Prevent skin problems that arise from chemical reactions caused by constant exposure to soaps, solvents and other mild chemicals. Powdered to go on and off easily. Available in small, medium and large sizes. Sold in boxes of 100.

Description	Item#	Box of 100
Small	<b>805-1043</b>	<b>\$10.35</b>
Medium	<b>805-1041</b>	<b>10.35</b>
Large	<b>805-1042</b>	<b>10.35</b>



**A Fire-Resistant Apron**

Made of fire-resistant fabric ideal for welding applications. Full-coverage design provides excellent protection of neck, chest and lap. Includes small chest pocket, large waist pocket and bottom flap for catching runaway parts. Comfortable neckband and extra-long waist strings for front tying. Navy blue. One size fits all. Measures 27"W x 36"L.

Description	Item#	Each
Fire-Resistant Apron	<b>827-1508</b>	<b>\$24.95</b>



**B Sueded Leather Bib Apron**

Durable and comfortable. Protects clothing when machining and working with rotary power equipment. There are no pockets to allow dirt and filings to collect. Made of heavy-weight, tanned, split rust-colored leather. Adjustable leather ties with brass grommet reinforcements. One size fits all. Measures 24"W x 36"L.

Description	Item#	Each
Sueded Leather	<b>827-1507</b>	<b>\$41.95</b>



**C Neoprene Apron**

Heavy-duty double-coated yellow neoprene apron for broad-spectrum protection from a wide range of chemicals, including acids, caustics and solvents. Features extra-long neck and waist ties. Measures 35"W x 45"L. Weighs 12½ oz. Recyclable.

Description	Item#	Each
Neoprene Apron	<b>827-1509</b>	<b>\$24.75</b>



**D Neoprene Sleeves**

These yellow neoprene sleeves provide lower-arm protection against a wide range of chemicals, oils, acids, caustics and solvents. Feature elastic cuffs on both ends for a secure fit. Measure 18" long. Sold by the pair.

Description	Item#	Each
Neoprene Sleeves	<b>827-1510</b>	<b>\$7.75</b>



**E Dust/Mist Mask – NIOSH-MSHA Approved for Dusts and Mists**

Strengthened outer shell provides greater toughness, durability and moisture resistance. Dual prestretched polymer head-straps require no adjustments and prevent hair from catching in elastic formable nosepiece. Large filter area assures easy breathing, speech, vision and comfort.

Description	Item#	Pkg. of 5	Item#	Box of 20	
				1-9	10+
Dust/Mist Mask	<b>805-1015</b>	<b>\$5.95</b>	<b>805-1010</b>	<b>\$22.25</b>	<b>\$18.91</b>



**F Comfort Fit Dust/Mist Mask – NIOSH-MSHA Approved for Dusts and Mists**

The most comfortable mask you'll ever wear! Adjustable aluminum nosepiece is actually contoured for improved facial fit and comfort. Inner foam seal across the bridge of the nose provides real comfort and a better seal. New lower profile fits better with glasses and goggles. The special microfiber filter maintains high filtration levels while making breathing easier. Disposable. Packaged 20 per box.

Description	Item#	Box of 20	
		1-9	10+
Comfort Fit Mask	<b>805-1020</b>	<b>\$25.95</b>	<b>\$22.06</b>





**A**

**A Attack Epoxy Solvent**

Dissolves cured epoxy and polyester resins without affecting surrounding material. Excellent for separating misaligned bonded items. For use on metal, glass, wood and similar materials.

Description	Item#	Each
8 fl. oz. Container	<b>821-2800</b>	<b>\$9.90</b>



**B**

**C**

**D**

**B - D Super Glue**

A transparent, high-strength, quick-setting adhesive for metal-to-metal and general-purpose bonding. No mixing required. Regular Super Glue dries in 45–60 seconds. Qwik-Dry sets up in just 10–20 seconds. Maximum strength is reached after 12 hours.

Regular Super Glue	Item#	EACH Prices		
		1-4	5-9	10+
<b>B. 2g Tube</b>	<b>811-2300*</b>	<b>\$2.25</b>	<b>\$2.03</b>	<b>\$1.91</b>
<b>C. 2g Pen</b>	<b>811-2305</b>	<b>2.40</b>	<b>2.28</b>	<b>2.04</b>
<b>D. 20g Liquid Bottle</b>	<b>811-2400</b>	<b>7.80</b>	<b>7.41</b>	<b>6.63</b>

Qwik-Dry Super Glue	Item#	EACH Prices		
		1-4	5-9	10+
2g Tube	<b>811-2310*</b>	<b>\$2.25</b>	<b>\$2.03</b>	<b>\$1.91</b>
20g Liquid Bottle	<b>811-2312</b>	<b>7.80</b>	<b>7.41</b>	<b>6.63</b>

*\*Five-piece minimum; please order in multiples of five.*

**E**



**E Debonder**

A solvent cleaner for all instant glues. Breaks bonds and removes hardened glues from all surfaces—including skin. Removes acrylic, enamel and epoxy paint overspray. Can also be used to prepare surfaces by removing grease and oil prior to application of Super Glue.

Description	Item#	EACH Prices	
		1-4	5+
10ml Tube	<b>811-2550</b>	<b>\$2.35</b>	<b>\$2.23</b>



**F**

**F Syringe Dispensers**

Plastic syringes with 18-gauge stainless steel needle for pinpoint delivery of adhesive, stoning and lubricating oil or diamond compound lapping oil to the exact place you want. Plunger works smoothly and slides evenly to prevent accidental flooding and sputtering. Use with our Epoxy 220 or 330, Devcon Epoxies and similar adhesives. Available in two sizes, each including tip sheath and cover. Sold in packages of six.

Description	Item#	PKG. of 6	
		1-3	4+
5cc Syringe	<b>811-2450</b>	<b>\$7.95</b>	<b>\$6.36</b>
10cc Syringe	<b>811-2451</b>	<b>9.95</b>	<b>7.96</b>



**G**

**G Chemical Splash Goggles**

Heavy-duty Chemical Splash Goggles feature generously sized frame and lens, which fit easily over prescription glasses. Clear lens with fog-free coating helps maintain excellent visibility. One-way vents let air in yet keep harmful liquids out. Adjustable headband ensures a comfortable, secure fit. Provide 99% UV protection. Exceed ANSI Z87.1-2003 impact requirements.

Description	Item#	Each
5cc Syringe	<b>270-0300</b>	<b>\$9.95</b>



**H**

**H Safety Glasses**

Comfortable, lightweight safety glasses with high-impact lenses for full eye protection while drilling, grinding, polishing and much more. One size fits all.

Description	Item#	Each
Safety Glasses	<b>270-0205</b>	<b>\$4.30</b>



**I**

**I Bausch & Lomb® Eye Wash**

This eye irrigating solution flushes away foreign particles, chlorine and other eye irritants. Gently cleanses and soothes irritated eyes. Includes sterile eye wash cup. Net wt: 4 fl. oz.

Description	Item#	Each
Eye Wash	<b>272-1002</b>	<b>\$5.75</b>

**A Metals Handbook – 10th Edition,  
Volume 5: Surface Cleaning, Finishing and Coating, By ASM International**

Covers every aspect of cleaning, finishing and coating technology, including conventional finishes, coatings and processes. Examines modern trends such as deposition in a vacuum, ion plating and ion implantation. Belongs on every shop's bookshelf.

Description	Item#	Each
Metals Handbook (hardcover, 715 pgs.)	<b>811-0155</b>	<b>\$210.00</b>

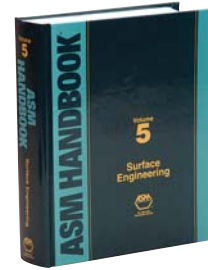

*Books cannot be returned for credit; damaged books can be exchanged for identical copies only.*

**A**

**B Machining Data Handbook  
3rd Edition, By Institute of Advanced Manufacturing Sciences**

Industry's best-known reference for making machining decisions. Completely revised and expanded into two volumes that address the latest technology for machinability of more than 1,500 materials. Covers more than 80 machining and grinding operations with speeds and feeds, as well as data for turning and milling, nontraditional machining and surface finishing. Offers solid advice for countering increased competition and rising costs of labor, equipment and materials. Provides both inch and metric units. Two-volume set.

Description	Item#	Each
Machining Data Handbook (hardcover, 2,258 pgs.)	<b>811-0130</b>	<b>\$245.00</b>

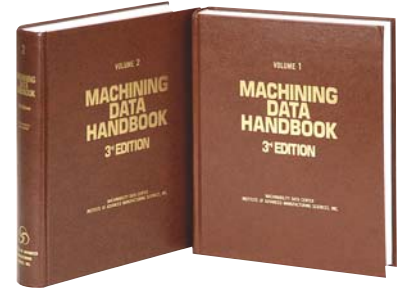

**B**

**C Blueprint Reading Basics – 2nd Edition, By Warren Hammer**

Written in a nontechnical and easy-to-understand format, this practical guide combines blueprint reading theory with industrial applications for machinists, technicians, inspectors and students. Includes illustrations and examples to help you visualize and develop drawings.

Description	Item#	Each
Blueprint Reading Basics (softcover, 314 pgs.)	<b>811-0125</b>	<b>\$29.95</b>

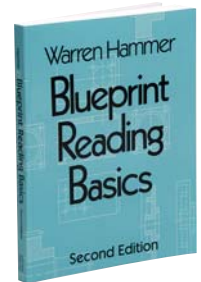

**C**

**D Metals Handbook – Desk Edition, By ASM International**

Considered the leading reference for metals technology. Divided into four parts: General Information includes a complete glossary of terms and common engineering tables; Properties and Selection covers all standard industrial alloys; Processing presents a how-to approach for solving production problems; Testing and Inspection examines general testing procedures and quality control.

Description	Item#	Each
Metals Handbook (hardcover, 1,294 pgs.)	<b>811-0120</b>	<b>\$235.00</b>



**D**

**E Introduction to Mold Making – By SPI Moldmakers Division**

An illustrated guide to common molding processes, standard mold components, mold problems and solutions. Intended for the first-year apprentice or student mold maker. Suitable for engineers, managers and buyers who need an orientation to the technology of building molds for plastic or rubber.

Description	Item#	Each
Introduction to Mold Making (softcover, 117 pgs.)	<b>811-0115</b>	<b>\$29.95</b>

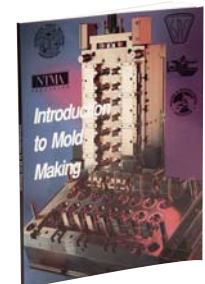

**E**

**F How to Make Injection Molds – 2nd Edition, By G. Menges and P. Mohren**

Newly revised for the design and manufacture of injection molds. Covers all aspects of material selection, fabricating cavities and cores, general mold design, hot runner systems, venting and ejection systems. Provides special focus on repair and cost-saving alterations to defective or improperly designed molds.

Description	Item#	Each
How to Make Injection Molds (hardcover, 540 pgs.)	<b>811-0140</b>	<b>\$149.95</b>

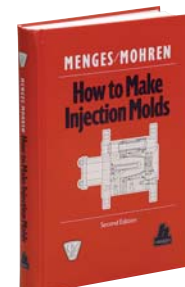

**F**



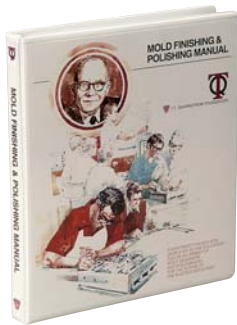

**A**

**A Mold Finishing and Polishing Manual – By Society of Plastics Engineers**

A valuable resource tool for critical mold making and finishing operations, including grinding techniques, polishing characteristics of steels and the use of abrasive cloth and paper, stones and diamond compounds. Discusses various types of molds as well as the different types of steels and other materials used in mold making. Explains techniques for using finishing equipment such as hand grinders and rotary tools, profilers, files, rifflers and chisels with descriptive charts, tables and photos. A must for the apprentice as well as the experienced mold maker.

Description	Item#	Each
Mold Finishing and Polishing Manual (spiral-bound, 61 pgs.)	<b>811-0215</b>	<b>\$56.00</b>

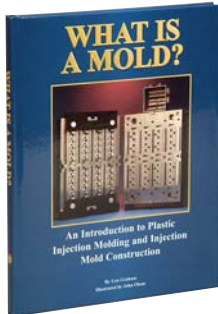

**B What is a Mold? – By Len Graham**

A well-organized, structured tutorial that explains basic terms and processes critical to an understanding of injection molds. Examines topics such as common plastics, injection molding, molding processes, injection molds and cold and hot runner delivery systems. Each chapter concludes with a test of the subject matter discussed. Illustrated with ten highly useful appendices and a glossary of terms.

Description	Item#	Each
What is a Mold? (hardcover, 156 pgs.)	<b>811-0143</b>	<b>\$50.00</b>

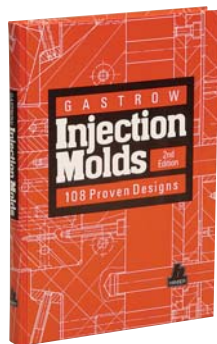

**C**

**C Gastrow Injection Molds: 108 Proven Designs 2nd Edition, By Hans Gastrow**

Not intended to be a textbook, Gastrow illustrates selected problems of injection mold construction with interesting and commercially tested solutions. Fully revised to include all types of injection molds, runners and gates, temperature controls, ejectors and standard components. Includes tested results, practical tips and proven shortcuts. Fully illustrated with detailed design drawings and examples.

Description	Item#	Each
Gastrow Injection Molds: 108 Proven Designs (hardcover, 248 pgs.)	<b>811-0150</b>	<b>\$129.95</b>

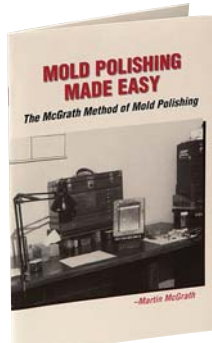

**D**

**D Mold Polishing Made Easy – By Martin McGrath**

A very detailed but simple approach to mold polishing. Emphasizes obtaining the required finish in the least amount of time. Takes the polisher step-by-step from the EDM or machine finish to the final #2 or #1 polish. Covers “orange peel” (and methods for avoiding or remedying the problem), timesaving tips on slots and radii, troubleshooting and repair of a finish and efficient use of ultrasonic polishers and air-powered tools. Very specifically suggests what kinds of stones, brushes and felts to use in each area and, most importantly, when to move on to the next step. Whether you are a tool and die student, mold polisher or veteran mold maker, this 6' x 9' reference manual should have a place in your toolbox.

Description	Item#	Each
Mold Polishing Made Easy (softcover, 24 pgs.)	<b>811-0210</b>	<b>\$14.95</b>

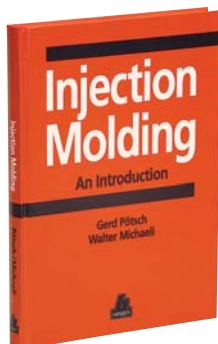

**E**

**E Injection Molding: An Introduction – By Gerd Potsch and Walter Michaeli**

A fundamental introduction to injection molding technology, this informative book presents key aspects of injection molding, including material behavior, machine and mold design and each step in the injection molding process. Also covers automation, simulation software and quality assurance. Illustrated with 249 figures.

Description	Item#	Each
Injection Molding: An Introduction (hardcover, 195 pgs.)	<b>811-0142</b>	<b>\$59.95</b>

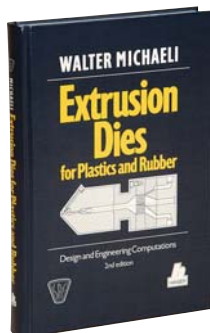

**F**

**F Extrusion Dies for Plastics and Rubber – 2nd Edition, By Walter Michaeli**

Presents a concise look at the full range of dies used for extrusion of plastics and elastomers. Revised with updated advice on the mechanical configurations of dies, handling, maintenance and computer-aided options and limitations. Fundamentals and computational procedures are easy to follow.

Description	Item#	Each
Extrusion Dies for Plastics and Rubber (hardcover, 340 pgs.)	<b>811-0135</b>	<b>\$99.95</b>





**Thank You for Your Order!**

As our business grows, so does our volume of incoming phone calls. We know your time is valuable, so to make sure you always have access to toll-free lines when placing your order, without the annoyance of busy signals, we have reserved a set of toll-free lines for orders only.

Our toll-free numbers can be used in all 50 states. Your order will be taken directly by an Inside Sales representative, entered immediately into our computer system, carefully picked, packaged and shipped.

**Opening an Account**

If you wish to open an account with us and you have a good rating with Dun & Bradstreet (D&B), we will immediately establish an open account with 1% 10, net 30 day terms. If you are not listed with D&B, please send us three trade references and one bank reference, or request an account application and return it to our office in Bridgeport, CT. We will immediately contact your references and inform you of our decision as soon as they respond.

**How to Place an Order**

Simply visit our Web site, phone, fax or E-mail your orders or requests for price quotes. Orders in by 3:00pm EST are shipped the same day. Of course, nonstock items and special-make items require additional time.

Visit our E-commerce Web site at [www.gesswein.com](http://www.gesswein.com) to view the latest products and pricing and to place orders on-line whenever convenient for you.

When you phone, please have your account number ready. This will help us enter your order quickly and give you current pricing and availability.

Each item in this catalog is coded with a seven-digit item number. Please use these numbers when placing your orders to ensure that the correct products are sent to you. Having these numbers also speeds up the order entry process.

However, please keep in mind that even if you don't have your account number or the item numbers, we are ready to assist. Simply let us know what you want and we will make it happen! If you cannot locate an item in our catalog, please be sure to let us know. We might be able to find it specially for you. And we're always adding to our product line.

**Prices**

For your convenience, we have included prices for all our cataloged products. *Please use as a guide only.* Fluctuations in raw material costs, manufacturing costs or foreign currency exchange rates may require sudden price adjustments. Our buyers are constantly seeking better prices without sacrificing the quality for which Gesswein is known. When successful, we pass the savings on to our customers, adjusting prices accordingly. Our prices do not include shipping and handling charges. All prices are in U.S. funds. Please feel free to call or fax for price quotes. We collect appropriate state and local sales taxes as required by the current laws of each state.

**Terms of Payment**

**Open Accounts**

Our terms are 1% 10, net 30 days. We reserve the right to impose a service charge of 1½% (18% APR) on all accounts not paid within 30 days.

**Credit Cards**

We currently accept Visa, MasterCard, American Express, Discover and Diners Club cards for payment. For your security, credit card transactions are verified with the credit card company and/or your issuing bank. The card number, expiration date and billing address are checked for your safety.



**COD Charges** (subject to change)

Due to the extra paperwork required for handling CODs, we charge \$6.00 per order. In addition, the carriers charge extra fees as follows:

- UPS \$6.00 per package (one order shipment can have more than one package).
- FedEx \$7.50 per package (one order shipment can have more than one package).
- Truck Approx. a \$54.00 minimum, or 3% of the total COD amount to be collected, whichever amount is higher. Any changes to a COD shipment will result in an additional charge as high as \$33.65.
- USPS \$4.00–\$10.00 per package (one order shipment can have more than one package; maximum \$600.00 COD for one package).

All carriers refuse to accept cash for COD payments, so all COD orders must be paid by money order or certified check in U.S. funds only. Company checks are accepted for preapproved accounts only. Contact our Credit Department if interested.

**All Other Accounts**

Our terms are net, payable in advance by check, money order, bank wire transfer, credit card or COD. Payments accepted in U.S. funds only.

**Leasing Options Available**

For equipment purchases totaling \$5,000.00 or more, you might want to consider leasing options. While Gesswein does not operate an in-house leasing program, we are certainly happy to work closely with the leasing firm of your choice. Contact our Credit Department for details.

### Important Warning – Please Read!

All products sold by Gesswein are restricted for use by professional tradespeople only. Additional documentation may be requested before shipment can be made. Our products are not intended for use by the general public. Those not knowledgeable in the usage of hazardous materials and equipment should not purchase these products since non-compliance with safety regulations can be dangerous to health and property.

### Product Design and Modifications

As part of our continuing effort to provide only the highest quality tools, equipment and supplies, we are always looking for new and improved products. The photographs and descriptions in this catalog are based on the products offered when this catalog was printed. We reserve the right to make changes in design and specifications without notice.

### Material Safety Data Sheets

Material Safety Data Sheets are available at your request for all products that contain hazardous ingredients. MSDS contain important user information such as safety recommendations and emergency procedures.

### Returns

If for any reason you wish to return merchandise, simply refer to the back of your packing slip. If you require any assistance, contact our Customer Service associates at 1-800-544-2043, and they will be happy to help. Please be prepared to give us your account number, pick list number and date shipped. This information is on the packing slip and also on your invoice. All returns must be shipped prepaid and be in unused and resellable condition. Please make sure you carefully package the merchandise to avoid damage during shipment. We do not accept collect or COD shipments. Any items we authorize to be returned at our expense should be via the carrier we specify.

Additional restrictions:

- We reserve the right to charge a restocking fee for cataloged products returned after 30 days.
- Nonstock items ordered specially for you are subject to a restocking charge.
- Items made to your specifications are not returnable.
- Returns will be credited in the same manner as paid.
- Hazardous items can be returned only by authorized hazardous goods shippers.

### Inside Sales

To place an order, check prices or request literature:  
☎ 1-800-243-4466 or 1-203-366-5400  
(8:30am–5:00pm EST)  
FAX 1-203-366-3953 • E-mail: [sales@gesswein.com](mailto:sales@gesswein.com)

### Technical Services

For technical service or product information, MSDS requests, shop setups or repairs:  
☎ 1-800-544-2043 or 1-203-366-5400  
(9:00am–5:00pm EST)  
FAX 1-203-335-0300 • E-mail: [info@gesswein.com](mailto:info@gesswein.com)

### Customer Service

For inquiries concerning orders already placed and/or received:  
☎ 1-800-544-2043 or 1-203-366-5400  
(8:30am–5:00pm EST)  
FAX 1-203-366-3953 • E-mail: [custserv@gesswein.com](mailto:custserv@gesswein.com)

### Credit

For credit or billing inquiries:  
☎ 1-203-366-5400  
(8:30am–5:00pm EST)  
FAX 1-203-331-8870 • E-mail: [info@gesswein.com](mailto:info@gesswein.com)

### Web Site

[www.gesswein.com](http://www.gesswein.com)

Please visit our E-commerce Web site. This full-featured site gives you the ability to place an order on-line as easily as dropping items into a shopping cart.

You will also have instant access to technical product information. Plus you will get the same great service you have counted on from Gesswein since 1914.



# Order On-Line!

## [www.gesswein.com](http://www.gesswein.com)

Now Gesswein is only a few mouse-clicks away! Come visit our brand-new E-commerce Web site: [www.gesswein.com](http://www.gesswein.com). Shop for products, find answers to technical questions, and review the latest industry news, all at your convenience. Our site gives you the power to do business with us faster than ever. When you think on-line, think Gesswein.

## Shipping Policy

Shipping and handling charges are F.O.B. shipping point. A small handling fee is presently charged on all original orders. The method of shipment will be left to our discretion unless you request a specific method. If timing is critical, we can often provide same-day delivery to most major cities. Please ask for a price quote.

### USPS Shipments

All postage and handling charges are F.O.B. shipping point. Orders are shipped postage prepaid, and the postage appears on your invoice. No hazardous goods accepted.

#### USPS Charges – in Addition to the Postage

(subject to change)

- \$5.10 minimum charge for COD per package (limit \$1,000.00 total COD amount per package)

### UPS Shipments

All shipping and handling charges are F.O.B. shipping point. Orders are shipped freight prepaid, and the freight appears on your invoice along with your UPS tracking number.

#### UPS Charges – in Addition to the Freight Charge

(subject to change)

- \$12.50 charge for Saturday delivery
- \$9.00 charge for each COD package
- \$20.00 charge for each hazardous carton via ground
- \$10.00 charge for any changes to shipments after pickup (no payment changes allowed for COD shipments)
- \$6.00 special handling charge for items in pails or drums (also applies to any package that exceeds 60" or has a second-longest side exceeding 30")
- \$6.00 handling charge for any package over 70 lbs.

UPS offers a wide range of guaranteed delivery options to fit your needs. However, not all areas have every service available. Ask your Inside Sales representative to confirm your ZIP code for a specific time-of-day delivery commitment:

**UPS SonicAir® Service** – Next-flight-out service can be same-day if conditions are met.

**UPS Next Day Air Early A.M.<sup>SM</sup>** – Delivery by 8:00 or 8:30am.

**UPS Next Day Air® (aka UPS RED)** – Delivery to every address coast-to-coast and Puerto Rico by 10:30am, noon or end of day.

**UPS Next Day Air Saver<sup>SM</sup>** – Delivery to specific destinations throughout the continental U.S. by 3:00pm, 4:00pm or end of day.

**UPS 2nd Day Air A.M.<sup>SM</sup>** – Morning delivery on the second business day to most metro-commercial addresses throughout the U.S.

**UPS 2nd Day Air® (aka UPS BLUE)** – Delivery by the second business day to every address coast-to-coast and Puerto Rico.

**UPS 3 Day Select®** – Delivery within three business days throughout the 48 contiguous states.

**UPS Ground** – Delivery for entire U.S. and Puerto Rico.

### FedEx Shipments

Simply provide us with your FedEx account number, advise how you want your order shipped, and we'll bill your FedEx account. No hazardous items may be shipped via FedEx.

#### FedEx Charges – in Addition to the Freight Charge

(subject to change)

- \$12.50 charge for Saturday delivery
- \$8.50 charge for each COD package
- \$10.00 charge for any changes to shipments after pickup

FedEx offers a wide range of guaranteed delivery options to fit your needs. However, not all areas have every service available. Ask your Inside Sales representative to confirm your ZIP code for a specific time-of-day delivery commitment:

**First Overnight** – Delivery by 8:30am.

**Priority Overnight** – Delivery by 10:30am.

**Standard Overnight** – Delivery by 3:00pm.

**2 Day** – Delivery by the second business day.

**Express Saver** – Delivery within three business days.

**Ground** – Delivery to continental U.S. within one to five business days and three to seven days for Alaska and Hawaii.

### Truck Shipments

All shipping and handling charges are F.O.B. shipping point. If you request a specific carrier, we will be happy to send your shipment collect via that carrier. Otherwise, we have negotiated lower rates with select carriers and will pass savings on to you. Orders are shipped freight prepaid, and the freight appears on your invoice. If the trucker will have to off-load your shipment to a smaller delivery truck (e.g., if you have limited access to your door because of a narrow alleyway), there may be a delay in delivery. Please make us aware of any potential problems so we can take steps to minimize delays. We will phone you the day the shipment is picked up at our facility in Bridgeport, CT, and provide you with the PRO (tracking) number, trucking charge and estimated delivery date.

#### Truck Shipment Charges – in Addition to the Freight Charge (subject to change)

The following services can generate extra charges above the normal trucking rates:

- Residential delivery (minimum \$35.00)
- Liftgate service (minimum \$49.00)
- Inside delivery (minimum \$35.00). Inside delivery is simply placing the shipment inside your door. If you require further assistance, it can be arranged at a premium rate.
- Hazardous goods surcharge (minimum \$12.00 per shipment)
- Redelivery due to customer unavailability (minimum \$39.00)
- Telephone call notification by trucker prior to delivery (minimum \$33.00)
- Any changes to shipment after pickup from F.O.B. point (minimum \$30.00)
- COD fee (\$54.00 minimum or a percentage of the total COD amount to be collected, whichever is higher)

### Shipping Damage

Orders always leave our facility in excellent condition. Our shipping terms are F.O.B. shipping point, which means you assume ownership the moment your order is picked up by the carrier. Therefore, in the unfortunate circumstance that you find any damage to your shipment, *you as the owner must file a claim with the carrier*. Gesswein will be happy to assist you in any way possible, but you must file the claim yourself.

- If you see any obvious outside damage to a shipping carton, you must write “Damaged” on the carrier’s delivery sheet.
- Save all cartons and packing materials. Do not return shipment.
- If, after initial inspection of the shipment, you discover concealed damage, you must promptly contact the carrier for inspection *and save all shipping materials*.
- Gesswein will not assume responsibility for any losses that occur due to your failure to follow these steps.

### Truck Shipments

All carriers are liable for any damages that occur during transit. You are responsible for making sure all cartons that are listed on your freight bill have actually been delivered. If you find a shortage or suspect a carton might have been damaged during transit, you or the trucker must make a notation of this on the delivery receipt. Do not sign the receipt without a notation. *Retain all cartons and packing materials* until after the inspection is completed.

If shortages or damages are discovered after the packages are opened (concealed loss or damage), notify the carrier within 15 days and request an inspection. *Also retain all cartons and packing materials* until after the inspection is completed. Gesswein will not assume responsibility for any losses that occur due to your failure to follow these steps.

### UPS Shipments

United Parcel Service is liable for any loss or damage that occurs during transit. If a shipment is not delivered to you in proper order, make a notation on the delivery receipt. Contact your local UPS office within 10 days so that we can submit a claim on your behalf and arrange for a replacement. *Save all cartons and packing materials* until after the inspection is completed.

No changes can be made to a COD shipment after pickup.

If shortages or damages are discovered after the packages are opened (concealed loss or damage), notify the carrier within 15 days and request an inspection. *Also save all cartons and packing materials* until after the inspection is completed. Gesswein will not assume responsibility for any losses that occur due to your failure to follow these steps.

### FedEx Shipments

FedEx is liable for losses or damages that occur during transit. If the shipping cartons are obviously damaged, you must write this on the driver’s copy of the delivery receipt. You have 15 days to inspect for hidden damage, so don’t delay. *In either case, all cartons and packing materials have to be available for inspection*. Please keep in mind that FedEx requires written notification of possible claims within 15 days of shipment. Gesswein will not assume responsibility for any losses that occur due to your failure to follow these steps.

### Shipping Hazardous Materials

When shipping of hazardous materials is prohibited by a specific means, we will ship by the best method possible. UPS Ground and most trucking firms charge an additional fee for the transport of hazardous materials, including but not limited to acids and corrosive materials. UPS limits the quantity and type of hazardous items that may be shipped in one carton. Therefore, multiple cartons may have to be used for your order. UPS assesses their hazardous surcharges per carton. Most trucking firms charge per shipment. No hazardous items may be shipped via FedEx or USPS.

**Hazardous goods can only be shipped by those companies authorized to do so. Therefore, a return of hazardous items to Gesswein can be made only if your firm is an authorized shipper of such goods. Call tags and pickups cannot be issued.**

### Material Safety Data Sheets

Material Safety Data Sheets are available at your request for all products that contain hazardous ingredients. MSDS contain important user information such as safety recommendations and emergency procedures.

### Important Warning – Please Read!

**All products sold by Gesswein are restricted for use by professional tradespeople only. Additional documentation may be requested before shipment can be made. Our products are not intended for use by the general public. Those not knowledgeable in the usage of hazardous materials and equipment should not purchase these products since non-compliance with safety regulations can be dangerous to health and property.**



**Measurement Comparison Chart**

inch	mm	B&S Gauge	Stubs Steel Wire	Drill#
.0030	0.076	-	-	-
.0040	0.102	-	-	-
.0050	0.127	-	-	-
.0059	0.150	-	-	97
.0060	0.152	-	-	-
.0063	0.160	-	-	96
.0067	0.170	-	-	95
.0070	0.178	-	-	-
.0071	0.180	-	-	94
.0075	0.190	-	-	93
.0079	0.200	-	-	92
.0080	0.203	-	-	-
.0083	0.210	-	-	91
.0087	0.220	-	-	90
.0090	0.229	-	-	-
.0091	0.230	-	-	89
.0095	0.241	-	-	88
.0100	0.254	-	-	87
.0105	0.267	-	-	86
.0110	0.279	-	-	85
.0115	0.292	-	-	84
.0120	0.305	-	-	83
.0125	0.320	-	-	82
.0130	0.330	-	80	81
.0135	0.343	-	-	80
.0140	0.356	-	79	-
.0142	0.361	27	-	-
.0145	0.369	-	-	79
.0150	0.381	-	78	-
.0159	0.404	26	-	-
.0160	0.406	-	77	78
.0179	0.455	25	-	-
.0180	0.457	-	76	77
.0200	0.508	-	75	76
.0201	0.511	24	-	-
.0210	0.533	-	-	75
.0220	0.559	-	74	-
.0225	0.572	-	-	74
.0226	0.574	23	-	-
.0230	0.584	-	73	-
.0240	0.610	-	72	73
.0250	0.635	-	-	72
.0253	0.643	22	-	-
.0260	0.660	-	71	71
.0270	0.685	-	70	-
.0280	0.712	-	-	70
.0285	0.724	21	-	-
.0290	0.737	-	69	-
.0293	0.743	-	-	69
.0300	0.762	-	68	-
.0310	0.787	-	67	68
.0320	0.813	20	66	67
.0330	0.838	-	65	66
.0350	0.889	-	64	65
.0359	0.912	19	-	-
.0360	0.914	-	63	64
.0370	0.940	-	62	63
.0380	0.965	-	61	62
.0390	0.990	-	60	61
.0400	1.016	-	59	60

inch	mm	B&S Gauge	Stubs Steel Wire	Drill#
.0403	1.024	18	-	-
.0410	1.041	-	58	59
.0420	1.067	-	57	58
.0430	1.092	-	-	57
.0450	1.143	-	56	-
.0453	1.151	17	-	-
.0465	1.181	-	-	56
.0500	1.270	-	55	-
.0508	1.290	16	-	-
.0520	1.321	-	-	55
.0550	1.397	-	54	54
.0571	1.450	15	-	-
.0580	1.473	-	53	-
.0595	1.512	-	-	53
.0630	1.600	-	52	-
.0635	1.613	-	-	52
.0641	1.629	14	-	-
.0660	1.676	-	51	-
.0670	1.702	-	-	51
.0690	1.753	-	50	-
.0700	1.778	-	-	50
.0720	1.829	13	49	-
.0730	1.854	-	-	49
.0750	1.905	-	48	-
.0760	1.930	-	-	48
.0770	1.956	-	47	-
.0785	1.994	-	-	47
.0790	2.007	-	46	-
.0808	2.052	12	-	-
.0810	2.057	-	45	46
.0820	2.083	-	-	45
.0850	2.159	-	44	-
.0860	2.184	-	-	44
.0880	2.235	-	43	-
.0890	2.261	-	-	43
.0907	2.304	11	-	-
.0920	2.337	-	42	-
.0935	2.378	-	-	42
.0950	2.413	-	41	-
.0960	2.438	-	-	41
.0970	2.464	-	40	-
.0980	2.489	-	-	40
.0990	2.515	-	39	-
.0995	2.528	-	-	39
.1010	2.565	-	38	-
.1015	2.578	-	-	38
.1019	2.588	10	-	-
.1030	2.616	-	37	-
.1040	2.642	-	-	37
.1060	2.692	-	36	-
.1065	2.705	-	-	36
.1080	2.743	-	35	-
.1100	2.794	-	34	35
.1110	2.819	-	-	34
.1120	2.845	-	33	-
.1130	2.870	-	-	33
.1144	2.906	9	-	-
.1150	2.921	-	32	-
.1160	2.946	-	-	32

inch	mm	B&S Gauge	Stubs Steel Wire	Drill#
.1200	3.048	-	31	31
.1270	3.226	-	30	-
.1285	3.264	8	-	30
.1340	3.404	-	29	-
.1360	3.454	-	-	29
.1390	3.531	-	28	-
.1405	3.573	-	-	28
.1430	3.636	-	27	-
.1440	3.662	-	-	27
.1443	3.670	7	-	-
.1460	3.712	-	26	-
.1470	3.758	-	-	26
.1480	3.763	-	25	-
.1495	3.802	-	-	25
.1510	3.835	-	24	-
.1520	3.861	-	-	24
.1530	3.886	-	23	-
.1540	3.912	-	-	23
.1550	3.937	-	22	-
.1570	3.988	-	21	22
.1590	4.039	-	-	21
.1610	4.085	-	20	20
.1620	4.111	6	-	-
.1640	4.162	-	19	-
.1660	4.212	-	-	19
.1680	4.263	-	18	-
.1695	4.302	-	-	18
.1720	4.371	-	17	-
.1730	4.396	-	-	17
.1750	4.447	-	16	-
.1770	4.498	-	-	16
.1780	4.523	-	15	-
.1800	4.570	-	14	15
.1819	4.618	5	-	-
.1820	4.621	-	13	14
.1850	4.697	-	12	13
.1880	4.773	-	11	-
.1890	4.799	-	-	12
.1910	4.855	-	10	11
.1935	4.919	-	-	10
.1940	4.932	-	9	-
.1960	4.982	-	-	9
.1970	5.008	-	8	-
.1990	5.059	-	7	8
.2010	5.105	-	6	7
.2040	5.182	-	5	6
.2043	5.189	4	-	-
.2055	5.220	-	-	5
.2070	5.258	-	4	-
.2090	5.309	-	-	4
.2120	5.381	-	3	-
.2130	5.406	-	-	3
.2190	5.559	-	2	-
.2210	5.615	-	-	2
.2270	5.768	-	1	-
.2280	5.793	-	-	1
.2294	5.829	3	-	-
.2576	6.543	2	-	-
.2893	7.346	1	-	-

**Fractional Measurement Conversion Chart**

Fraction	inch	mm
1/64	.0156	0.3969
1/32	.0313	0.7937
3/64	.0469	1.1906
1/16	.0625	1.5875
5/64	.0781	1.9843
3/32	.0937	2.3812
7/64	.1094	2.7781
1/8	.1250	3.1750
9/64	.1406	3.5718
5/32	.1562	3.9687
11/64	.1719	4.3656
3/16	.1875	4.7624
13/64	.2031	5.1593
7/32	.2187	5.5562
15/64	.2344	5.9530
1/4	.2500	6.3499

Fraction	inch	mm
17/64	.2656	6.7468
9/32	.2812	7.1437
19/64	.2969	7.5405
5/16	.3125	7.9374
21/64	.3281	8.3343
11/32	.3438	8.7312
23/64	.3594	9.1280
3/8	.3750	9.5249
25/64	.3906	9.9217
13/32	.4062	10.3186
27/64	.4219	10.7155
7/16	.4375	11.1124
29/64	.4531	11.5092
15/32	.4687	11.9061
31/64	.4844	12.3030
1/2	.5000	12.6999

Fraction	inch	mm
33/64	.5156	13.0968
17/32	.5313	13.4936
35/64	.5469	13.8905
9/16	.5625	14.2874
37/64	.5781	14.6842
19/32	.5938	15.0811
39/64	.6094	15.4780
5/8	.6250	15.8749
41/64	.6406	16.2717
21/32	.6563	16.6686
43/64	.6719	17.0655
11/16	.6875	17.4623
45/64	.7031	17.8592
23/32	.7188	18.2561
47/64	.7344	18.6529
3/4	.7500	19.0498

Fraction	inch	mm
49/64	.7656	19.4467
25/32	.7813	19.8436
51/64	.7969	20.2404
13/16	.8125	20.6373
53/64	.8281	21.0342
27/32	.8438	21.4311
55/64	.8594	21.8279
3/8	.8750	22.2248
29/32	.9063	23.0185
59/64	.9219	23.4154
15/16	.9375	23.8123
61/64	.9531	24.2091
31/32	.9688	24.6060
63/64	.9844	25.0029
1	1.0000	25.3998

## Featured Manufacturers

### 3M Abrasives

#### Abrasive Bands

3M Aluminum Oxide.....	67
3M Cubitron Ceramic.....	68
3M Flex Diamond.....	68
3M Imperial Film.....	66
3M Trizact.....	66

#### Abrasive Polishing Paper

3M Imperial.....	76
3M Wetordry.....	76
3M Wetordry Polishing.....	76

#### Diamond Micro Finishing Film.....

#### Diamond QRS Discs.....

#### Grinding Wheels.....

#### Hand Pads, Diamond.....

#### Hand Pads, Scotch-Brite.....

#### Radial Bristle Discs & Sets.....

#### Roloc Discs & Holders.....

#### Unitized Wheels, Scotch-Brite EXL.....

### Cratex

#### Rubberized Abrasives.....

### Foredom

#### Flexible Shafts.....

#### Handpiece Drill Presses & Holders.....

#### Mini Vise.....

#### Motor Hangers.....

#### Rotary Handpieces.....

#### Speed Controllers.....

### Grobet

#### Files.....

### Norton Abrasives

#### Abrasive Polishing Paper

Durite.....	76
-------------	----

Waterproof.....	76
-----------------	----

#### Arkansas

Bench Stones.....	26, 27
-------------------	--------

Engraver's Point.....	26
-----------------------	----

Files.....	26, 27
------------	--------

#### Bear-Tex Wheels.....

#### Crystolon Stones.....

#### Dressing Stone.....

#### Hand Pads, Bear-Tex.....

#### India Files.....

### SGS End Mills

#### Power Carb.....

#### Solid Carbide.....

#### Solid Carbide for Aluminum.....

#### Turbo Carb.....

## Alphabetical Index

### A

#### Abrasives

##### Bands

3M Aluminum Oxide.....	67
3M Cubitron Ceramic.....	68
3M Flex Diamond.....	68
3M Imperial Film.....	66
3M Trizact.....	66
Aluminum Oxide.....	67
Propel-Loc.....	65

##### Bands, Drum Arbors for.....

##### Belts, Sticks & Sets.....

##### Caps, Holders & Sets.....

##### Cartridge Rolls & Mandrels.....

##### Cloth, Lightning Metalight.....

##### Cords & Tapes, Mitchell's.....

##### Cut-Off Discs.....

##### Polishing Paper

3M Imperial.....	76
3M Wetordry.....	76
3M Wetordry Polishing.....	76
Emery.....	76
Norton Durite.....	76
Norton Waterproof.....	76

##### Rubberized

Brightboy.....	56
Cera.....	53
Cratex.....	54-55
Edenta Titanium Polishers.....	52
PT8 Polishers.....	52
Pumice Wheels.....	51
Rub-Out Stick & Holder.....	49
Rugi.....	56
Silicon Carbide.....	51, 52

##### Stones, Finishing.....

##### Accu-Finish II.....

##### Adapter Chuck.....

##### Air Filter/Regulator.....

##### Air Fittings & Hoses.....

##### Air Handpiece Oil.....

##### Air Handpiece Variable-Speed Foot Controller.....

#### Air Handpieces

##### Reciprocating Handpieces

FPD.....	113
Super Hand.....	111

TL70 .....	113
UHT (Ushio).....	113
<b>Rotary Handpieces, Angled</b>	
Suhner .....	110
UHT (Ushio).....	110
<b>Rotary Handpieces, Straight</b>	
HS80 .....	110
HT60.....	111
Nitto Kohki.....	111
NSK .....	111, 112
Suhner.....	110
UHT (Ushio).....	110
<b>Rotary Sanders, Angled</b>	
AG22 .....	112
Nitto Kohki.....	112
<b>Aprons</b> .....	289
<b>Arbors for Polishing Motors</b> .....	136

## B

<b>Bench Stones</b> .....	26, 27, 29
<b>Blanks &amp; Cutters</b> .....	190-191
<b>Books</b> .....	291-292
<b>Brightboy Rubberized Abrasives</b> .....	56

### Brushes

<b>EL-192</b> .....	118
<b>Hand Brushes</b> .....	121
<b>Scratch</b> .....	120
<b>Supra</b>	
ME .....	117
MK.....	118
MKM.....	116
MM .....	116
<b>Wheel</b> .....	119-120

### Bufs

Chamois .....	125
Chamois, Faux .....	125, 127
Cotton String .....	127, 130
Felt.....	125, 127
Muslin.....	122-124, 127, 130
Synflex.....	127

### Burs

<b>Busch</b> .....	180-183
<b>Carbide</b>	
Diamond-Cut .....	175

Friction Grip.....	176
Gesswein .....	171
Long-Shank .....	172
Nonferrous .....	172
S.S. White.....	173
Solid .....	166-170
Super .....	174
<b>High Speed Steel</b> .....	177-179
<b>Typhoon</b> .....	183

<b>Bur, Holders for</b> .....	184
-------------------------------	-----

## C

<b>CBN Pins</b> .....	152-153
<b>Center Punch</b> .....	186
<b>Cera Rubberized Abrasives</b> .....	53
<b>Ceramic Diamond Stones, Super</b> .....	23
<b>Ceramic Stones, Super</b> .....	22, 23
<b>Chisels</b> .....	253
<b>Cleaning Cloths</b> .....	287
<b>Cloth, Diamond</b> .....	163
<b>Cloth, Lightning Metalight</b> .....	77

### Compounds

<b>Buffing</b> .....	132-133
<b>Diamond</b>	
Gesswein .....	144
Supra.....	145
Lubricant/Thinner .....	145
<b>Polishing</b> .....	135

<b>Cone Loc Drum</b> .....	77
<b>Cotton Fiber Wheels, Quick Change</b> .....	60
<b>Cratex Rubberized Abrasives</b> .....	54-55
<b>Cut-Off Discs</b> .....	50
<b>Cut-Off Discs, Diamond</b> .....	165
<b>Cutters, Diamond</b> .....	157, 160

## D

<b>Debonder</b> .....	290
<b>Deburrers, Swiveling</b> .....	254
<b>Deflasher, Ceramic</b> .....	254
<b>Demagnetizer/Magnetizer</b> .....	233

### Diamond

<b>Cloth</b> .....	163
<b>Compounds</b>	
Gesswein .....	144
Supra.....	145
<b>Cut-Off Discs</b> .....	165
<b>Cutters</b> .....	157, 160
<b>Dressing Block</b> .....	53

**Files**

Hand, 3M.....149  
 Hand & Poli, Gesswein .....146-147  
 Needle, Micro & Poli, Spectra.....148-149

**Grinding Wheels** .....151

**Hand Lappers** .....150

**Hand Pads, 3M**.....164

**Lubricant/Thinner**.....145

**Micro Finishing Film, 3M**.....162

**PSA Film & Foil**.....161

**QRS Discs, 3M** .....164

**Scriber** .....150

**Sharpeners**.....150

**Sheet, Diamond Copper**.....165

**Tip Set for Mini Filler**.....149

**Wheel Dressers**.....150, 154-155

**Wheels & Points**.....156-159, 163

**Disposable Gloves**.....288

**Dressing Stone for Rubber Polishing Rods** .....51

**Dressing Stones**

Gesswein .....47  
 Norbide, Norton.....47  
 PBC .....47  
 Type VS .....47

**Drills**

**Countersinks, Combined**.....187

**Solid Carbide, Jobbers Length**.....187

**Twist**

Blue Ribbon .....186  
 Busch .....185  
 Supra.....185

**Drum Arbors** .....68

**Drum Pump**.....284

**Duplex Spring Adapter**.....106

**Dust Collectors**

#250 .....142  
 #60B .....141  
 #75-0.....139  
 #762 .....141  
 #90-D .....140  
 Quatro.....142-143  
 Torit.....138

**Dust Masks**.....289

**E**

**Edenta Titanium Rubberized Abrasive Polishers**.....52

**EDM Tapping, EDTapper** .....193

**End Mills**

Power Carb, SGS.....190  
 Solid Carbide, SGS .....188  
 Solid Carbide for Aluminum, SGS.....189  
 Turbo Carb, SGS .....190

**Engraver, Electric** .....108

**Engraver's Blocks** .....250

**Engraver's Chuck** .....26

**Engraver's Point, Norton**.....26

**Epoxy Solvent**.....290

**Eye Wash**.....290

**F**

**Felt**

Bobs .....128-129  
 Laps.....125  
 Sticks.....130  
 Wheels.....126

**Fiber Wheels & Discs**

3M Scotch-Brite.....64  
 FR .....62  
 Satin Finish .....62  
 SLP.....62

**File Card**.....199

**File Handles**.....211

**Files**

Diamond .....146-149  
 Escapement Files, Swiss.....218-220  
 Flexi-Files.....221  
 Habilis Files, Swiss .....212  
 Needle Files, Swiss .....213-217  
 Needle Files, Valtitan.....212  
 Pattern Files, American.....208-210  
 Pattern Files, Swiss .....198-207  
 Screwhead File.....212  
 Steel Files .....212  
 Vulcanite File, Swiss .....212

**Files, Diamond**

3M .....149  
 Gesswein .....146-147  
 Spectra .....148-149  
 Tip Set .....149

**Finger Guards & Tape** .....137

**Flap Wheels**

Cloth .....63  
 Fiber .....62  
 Satin Finish.....62



**Flexible Shaft, Foredom**

Motors .....	100–101
Reciprocating Handpieces .....	109
Rotary Handpieces .....	103–105
Speed Controllers .....	102
Handpiece Accessory Set .....	103
Handpiece Duplex Spring Adapter .....	106
Handpiece Drill Presses & Holders .....	107
Handpiece Oil.....	106
Motor Hangers.....	106

**G****Gesswein****Finishing Stones**

Diemaker .....	10–11
EDM.....	6–7
EDM Blue.....	5
GP .....	8
Moldmaker .....	13
Moldmaker Plus.....	12
Oil-Treated .....	9
Pencil.....	16
Premium White.....	9
RA .....	4
Rough Out .....	14
Super Fine .....	15
Ultra-Soft.....	15
White Polishing .....	14

**Finishing Stone, Sets**

12-Piece Intro Finishing Sets .....	19
20-Piece Polishing Sets .....	18
48-Piece Pencil Set II.....	17
54-Piece Finishing Set .....	18
96-Piece Discovery Set IV .....	19

**Mounted Points**

Blue .....	43
Pink .....	46
Red.....	44
White .....	45

**Mounted Stones**

Blue .....	32–36
Light Blue .....	42
Red .....	37–41

**Mounted Stone, Sets**

Blue .....	36
Light Blue .....	42
Red.....	41

Ultrasonic Cleaning Solution .....	284
------------------------------------	-----

<b>G-FLEX Mounted Cylinders</b> .....	59
---------------------------------------	----

<b>Glove Cote Hand Protectant</b> .....	288
---	-----

<b>GMX Discs, Sticks &amp; Wheels</b> .....	57
---	----

<b>GMX Mounted Cylinders</b> .....	58
------------------------------------	----

<b>Goggles, Safety</b> .....	290
------------------------------	-----

**Gravers**

Gesswein .....	248–249
----------------	---------

Gardon/Vallorbe .....	248
-----------------------	-----

Muller .....	248–249
--------------	---------

<b>Graver Handles</b> .....	251
-----------------------------	-----

**Gravers, Power**

Chicago.....	247
--------------	-----

Dremel.....	247
-------------	-----

Foredom .....	246
---------------	-----

Magna.....	247
------------	-----

<b>Graver Sharpener, Power Hone</b> .....	252
---	-----

<b>Graver Sharpeners, Fixtures</b> .....	253
--	-----

**Grinders, Electric**

Dremel.....	108
-------------	-----

Dumore.....	108
-------------	-----

**Grinding Wheels**

3M .....	49
----------	----

AirFlex.....	49
--------------	----

Diamond .....	151
---------------	-----

Norton .....	48
--------------	----

**H****Hammers & Mallets**

Brass Mallet .....	226
--------------------	-----

Brass/Nylon Mallet.....	226
-------------------------	-----

Chasing Hammer .....	226
----------------------	-----

Dead Blow Mallet.....	227
-----------------------	-----

Flat/Ball-Peen Hammer .....	226
-----------------------------	-----

Flat, Brass Hammer .....	226
--------------------------	-----

Nylon Mallet.....	227
-------------------	-----

Rawhide Mallet .....	227
----------------------	-----

<b>Hand Lapper, Deborit</b> .....	25
-----------------------------------	----

**Hand Pads**

Bear-Tex, Norton.....	65
-----------------------	----

Scotch-Brite, 3M.....	65
-----------------------	----

<b>Hand Pads, Holder</b> .....	65
--------------------------------	----

<b>Hand Pads, Mandrel</b> .....	65
---------------------------------	----

<b>Hemostats</b> .....	240
------------------------	-----

<b>Holders, Stone</b> .....	20–21
-----------------------------	-------

**I**

<b>Imaging Systems &amp; Software</b> .....	269–271
---	---------

<b>India Stones &amp; Files</b> .....	28–29
---------------------------------------	-------

**Inspection Systems**

Mantis Stereo Optical .....257  
 Meiji Stereo Zoom .....258  
 Stereo Zoom .....259

**J-K**

**Knife Blades & Handles** .....255

**L**

**Lamps**

Aven .....266-267  
 Dazor .....265-266  
 Flip Lamp .....268  
 Magnifier, Econo .....268  
 Magnifier Stand .....268  
 Multi Lamp .....268

**Lappers, Diamond** .....150

**Lens Cleaning Tissues** .....264

**Loupes** .....263-264

**Lube-Stik** .....168

**Lubricant/Thinner** .....145

**M**

**Magnifiers** .....262

**Magnifiers, Binocular**

Eschenbach Max Detail .....259  
 Magna Visor .....260  
 Magni-Focuser .....261  
 Optivisor .....260  
 Telesights .....261

**Man-O-Barrier Hand Protectant** .....288

**Mandrels**

Screw .....131  
 Tapered Thread .....131  
 Straight Thread .....131

**Mold Cleaners & Degreasers** .....286

**Mold Finish Gauges** .....165

**Mold Release Spray** .....286

**Mold Repair Kit** .....17

**Mold Rust Preventives** .....286

**Micro-Mesh Cushioned Abrasives** .....79

**Mini Vise, Foredom** .....107

**Mitchell's Abrasive Cords & Tapes** .....74

**N**

**Needle Files**

**Diamond** .....146-149  
**Swiss** .....213-217  
**Valtitan** .....212

**O-P**

**Paper Cones & Mandrels** .....72

**Pin Grinding Fixture** .....244

**Pliers & Cutters**

Bergeon .....240  
 Compound .....240  
 Foam-Grip .....238  
 Lindstrom .....234-235  
 Loop Opening .....240  
 Nylon Jaw .....240  
 Palm Grip .....238  
 Parallel-Jaw .....238  
 Standard-Weight .....237  
 Teborg .....236  
 Xuron .....239

**Polishing Motors**

#12 .....136  
 #15 .....136  
 Baldor .....136  
 Foredom .....141

**Power Hand 2X Finishing System** .....88-99

**Power Hone Graver Sharpener** .....252

**PSA**

**Discs & Holders** .....73  
**Film & Foil, Diamond** .....161  
**Strips** .....77

**PT8 Rubberized Abrasive Polishers** .....52

**Pumice Wheels** .....51

**Q-R**

**Quad-Hone Stone** .....27

**Quick Change Cotton Fiber Wheels** .....60

**Radial Bristle Discs & Sets** .....75

**Razor Saw** .....229

**Reamers** .....185

**Rifflers**

Diemaker's .....225  
 Swiss Diesinker's .....222-224

**Roloc Discs & Holders, 3M** .....61

**Rub-and-Rinse Stone Cleaner** .....31

**Rub-Out Stick & Holder** .....49

**Ruby Carvers** .....160

**Ruby Stones & Files**

Bench Stones .....25  
 Midget Files .....25  
 Stones .....24

**Rugi Rubberized Abrasive Cylinders** .....56

## S

Safety Glasses & Goggles.....	290
Sandblasters & Media.....	245
Sawblades & Sawframes.....	228-229
Scraper, Adjustable.....	254
Screwdrivers.....	241
Scribers.....	253
Simichrome.....	135
Snap-On Discs & Mandrel.....	74
Snips, Metal.....	240
Spindles for Polishing Motors.....	118
Split Mandrels.....	77
Spray-Pump Bottle.....	31
Stamp Sets.....	247
Stones, Finishing.....	2-19

## Steam

## Cleaners

Compact Jewel Jet.....	285
Cyclone.....	285
Deluxe Junior.....	285

Cleaning Powder.....	285
----------------------	-----

Steamostat.....	241
-----------------	-----

Stone Holders.....	20-21
--------------------	-------

Stoning Oils.....	31
-------------------	----

## Super Ceramic

Diamond Stones.....	23
---------------------	----

## Stones

Flat, Round & Sets.....	22
Mounted Cylinders.....	23
Unmounted Wheels.....	23

Super Dresser.....	23
--------------------	----

Super Glue.....	290
-----------------	-----

Syringe Dispensers.....	31
-------------------------	----

## T

Tapered Cone Points & Holders.....	72
------------------------------------	----

Third Hand.....	233
-----------------	-----

TolTec Microimage Measurer.....	256
---------------------------------	-----

## Torches

Casting.....	281
Little Torch.....	279-280
Small Torch.....	281

Tru-Stone.....	46
----------------	----

## Tweezers

Ceramic Tip.....	232
Cross-Locking.....	232
Dumont.....	230-231
Long-Reach.....	233

## U

Ultramax Ultrasonic Polishing Systems.....	80-87
--	-------

## Ultrasonic

## Cleaners

Compact Sonic Wave.....	283
Digisonic.....	283
Elma SX30H.....	283
L&R Quantrex.....	282
Sweep.....	282

## Cleaning Solutions

BCR Plus.....	284
Gesswein.....	284
OrganiCleen.....	284
Supra Galvex.....	284

## Unitized Wheels

Scotch-Brite EXL, 3M.....	64
Supra.....	60

## V

Vacuum Tweezer.....	232
---------------------	-----

## Vises

Bench Vises.....	244
Mini Vise, Foredom.....	107
PanaVise.....	243
Pin Vises.....	242
V-Block Vises.....	243

## W-Z

## Welders

Hydroflux.....	278
PUK 3 Spot.....	278
Weldmax 350 Microwelding System.....	272-277

## Wheels &amp; Discs

Cloth Flap.....	63
Fiber Flap.....	62
Fiber FR.....	62
Fiber SLP.....	62
Grinding.....	48
Satin Finish.....	62
Satin Finish Flap.....	62
Scotch-Brite, 3M.....	64

## Wood

Bobs.....	135
Sticks.....	134

## An Important Note About Our Products

All products sold by Gesswein are intended for use by professional tradespeople, not the general public. Additional documentation may be requested before shipment can be made. Those not knowledgeable in the usage of hazardous equipment and materials should not purchase these products since noncompliance with safety regulations can be dangerous to health and property.

## Material Safety Data Sheets

Material Safety Data Sheets (MSDSs) are available upon request for all products that contain hazardous ingredients. MSDSs contain important information such as safety recommendations and emergency procedures. The fastest way to access MSDS information is through our Web site, [www.gesswein.com](http://www.gesswein.com). Click on the Tech/MSDS button found on our home page, select MSDS and search alphabetically for the product. You can also call us Monday–Friday, 8:30am–5:00pm EST at 1-800-544-2043 or 1-203-366-5400.

## Eye Protection

Goggles or safety glasses with shields are recommended when using abrasive products for polishing, grinding or cutting.

## Hand Protection

Gloves are recommended but not required when using most abrasive products. Follow the manufacturer's guidelines.

## Hearing Protection

Earmuffs or earplugs may be required when using some abrasive products. See OSHA 29 CFR 1910.95 for statutory noise limits and requirements.

## Respiratory Protection

Consider the abrasive product and material to be ground, then select and use equipment in accordance with OSHA 29 CFR 1910.134 in USA or CSA Z94.4-M1982 in Canada.

## Engineering Controls

Provide process enclosure or local ventilation to keep dust below applicable limits and to meet hearing protection requirements.

## Operating Practices

- Safe operating practices must be a part of every operation.
- Be sure to read all safety information provided with applicable products.
- Always check products for damage before use.
- Before mounting wheels, use a tachometer to measure spindle speed.
- Ensure the mounting flanges, backplate or adapter supplied by the machine manufacturer are used and kept in good condition. ANSI Safety Requirements B7.1 provide wheel mounting requirements. Check mounting flanges for equal and correct diameter, and use blotters when supplied.
- Always mount, true and dress wheels in conformance with the guidelines published in ANSI Safety Requirements B7.1.
- Never exceed the maximum operating speed for any product.
- Avoid dropping or bumping wheels.
- When not using wheels, store in their original packaging materials to prevent chips and cracks and to allow easy wheel identification.



## **Vibrating and Reciprocating Tools**

Prolonged use of vibrating or reciprocating tools may result in vibration-induced circulation problems in the hands. Always follow safe operating procedures. The use of hand protection (i.e., insulated gloves) and taking frequent breaks can help minimize but not guarantee against injury. Operating these types of tools in cold weather or with a tight grip will reduce the period of operation before risking potential injury. Individuals with a tendency to suffer from poor circulation, frequently cold fingers or itchy hands should closely monitor the condition of their hands. If symptoms appear, seek medical advice immediately.

## **Pistol Grip Air Sanders**

Never use a high-speed air grinder as a portable sander. Use only sanding discs specifically designed for sanders. Because the speeds of these sanders far exceed the maximum rated speeds for grinding wheels, a potentially lethal wheel breakage may occur.

## **Depressed Center Cut-off Wheels and Snagging Wheels**

### ***Dos***

- Check all wheels for cracks or damage before use.
- Check machine speed against established safe operating speed marked on the wheel.
- Always use the guard furnished with the machine.
- Run wheel in a protected area for one minute before grinding.

### ***Don'ts***

- Don't use wheels that have been dropped or otherwise damaged.
- Don't use heavy side pressure on any thin straight cut-off wheel or thin depressed center wheel.
- Never use a grinding wheel with a rated speed that is less than that of the grinder.

## **Bench and Pedestal Wheels**

### ***Dos***

- Check all wheels for cracks or damage before use.
- Always use a safety guard and ensure work rest is properly adjusted.
- Always handle and store wheels in a careful manner.
- Check mounting flanges for equal and correct diameter, and use blotters when supplied.
- Check machine speed against established safe operating speed marked on wheel.

### ***Don'ts***

- Don't use a cracked wheel or one that has been dropped or damaged.
- Don't exceed recommended operating speeds.
- Don't tighten the mounting nut excessively.
- Don't jam work into the wheel.
- Don't sand wood, plastic or any other nonmetallic material on bench or pedestal grinders.

# Paul H. Gesswein & Co., Inc.

255 Hancock Avenue, P.O. Box 3998  
Bridgeport, Connecticut, USA 06605-0936  
☎ 1-203-366-5400 • FAX 1-203-366-3953  
E-mail: [info@gesswein.com](mailto:info@gesswein.com)

*Printed in USA ©2007 Brochure #890-2363*

## Orders

[www.gesswein.com](http://www.gesswein.com)

☎ 1-800-243-4466

FAX 1-203-366-3953

E-mail: [sales@gesswein.com](mailto:sales@gesswein.com)

*We accept*



*Please visit our full E-commerce Web site at [www.gesswein.com](http://www.gesswein.com)  
to shop for the latest products and take advantage of exclusive deals.*

### **Gesswein**

255 Hancock Ave., P.O. Box 3998  
Bridgeport, CT 06605, USA